

液晶模组规格书

LCM Specification

初定规格 Preliminary specification

正式规格 Official specifications

| | |
|-----------------------------|---|
| 项目编号 Project No. | TFT-H040A13ZDIST5N20 |
| 产品描述 Product Description | TFT LCD Module 400 x 3RGB x 960 Dots 4.0 Inch TFT LCD |



客户确认签章:

Signature by customer:

小批量试产 Trial production 大批量生产 Mass production

鑫洪泰科技（广东）有限公司

深圳市鑫洪泰电子科技有限公司

广东省深圳市龙岗区龙岗天安数码城 3 栋 B 座 1202-G

广东省东莞市凤岗镇东深公路 208 号天安数码城 N3 栋 3 楼

文档修订记录 Document revision history :

| 版本 Version | 日期 DATE | 修改说明 Modify description | 编制 PREPARED BY |
|---------------|------------|----------------------------|-------------------|
| 0-0 | 2022-03-09 | 初次编制 First compilation. | Liu. YL |
| | | | |
| | | | |
| | | | |

一、基本特征 General Feature:

| 项目 Item | 标准值 Standard Value | 单位 Unit |
|-------------------------------------|---|------------|
| 显示尺寸 Display Size | 4.0 | 英寸 Inch |
| 分辨率 Number of Pixels | 400 (H) * 3 (RGB) * 960 (V) | 点 dots |
| 显示区域 Active Area | 39.18 (H) * 94.03 (V) | 毫米 mm |
| 外形尺寸 Outline Dimension | 41.40 (H) * 101.58 (V) * 2.04 (D) <TFT> | 毫米 mm |
| 观看方向 Viewing Direction | 全 视角 FULL 0'clock | - |
| TFT 接口 TFT Interface | MIPI (Default 2 Lane) | - |
| TFT 驱动芯片 TFT Driver IC | ST7701S | - |
| TFT 驱动电压 TFT Driver Condition | VCI=3.3V, IOVCC=1.8V (Typ) | 伏 V |
| 背光-1 Backlight-1 | 白色 LED/8 颗/8 LEDs 串联 White LED/10 PCS/8 LEDs serial | - |
| 触摸屏 Touch Panel | <input checked="" type="checkbox"/> 不带触摸屏 <input type="checkbox"/> 带电阻触摸屏 <input type="checkbox"/> 带电容触摸屏 Whitout TP Whit RTP Whit CTP | - |
| 电容触摸屏驱动芯片 CTP Driver IC | - - - | - |
| 电容触摸屏驱动电压 CTP Driver Condition | VDD=3.3V (Typ) | 伏 V |
| TFT 液晶工作温度 Operation Temperature | -30 ~ 80 | 摄氏度 ℃ |
| TFT 液晶储存温度 Storage Temperature | -30 ~ 80 | 摄氏度 ℃ |

二、外形尺寸 Outline Dimensions

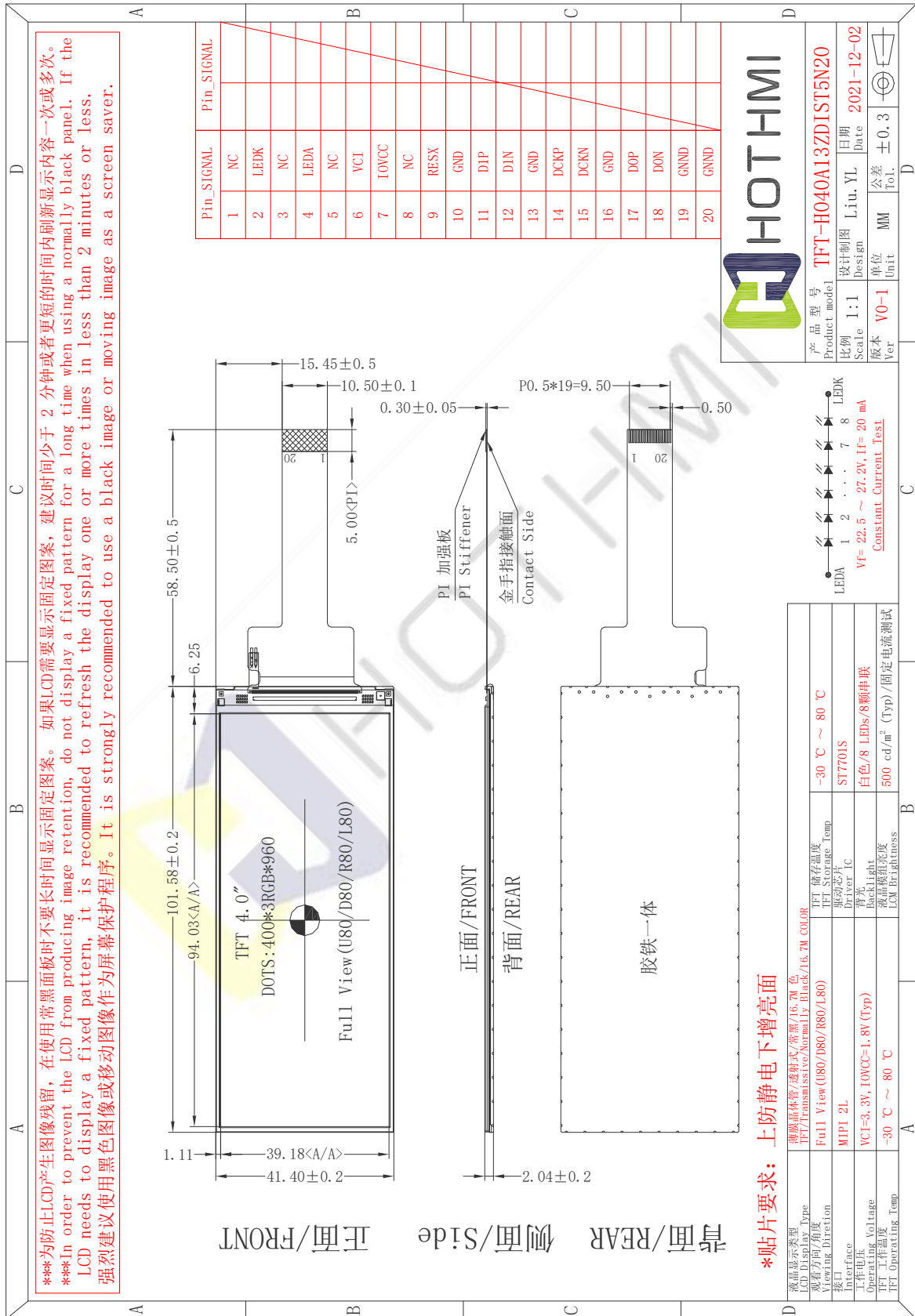

三、引脚说明 Pin Description

3.1. 模组引脚说明 TFT Pin Description

| 引脚编号 Pin NO. | 标号 Symbol | 详细描述 Description |
|-----------------|--------------|---|
| 1 | NC | No Connect |
| 2 | LEDK | LED Cathode |
| 3 | NC | No Connect |
| 4 | LEDA | LED Anode |
| 5 | NC | No Connect |
| 6 | VCI | Digital Power |
| 7 | IOVCC | IO Supply Voltage |
| 8 | NC | No Connect |
| 9 | RESX | - The external reset input - Initializes the chip with a low input. Be sure to execute a power-on reset after supplying power. |
| 10 | GND | Ground |
| 11 | D1P | MIPI DSI Differential Data Positive |
| 12 | D1N | MIPI DSI Differential Data Negative |
| 13 | GND | Ground |
| 14 | DCKP | MIPI DSI Differential Clock Positive |
| 15 | DCKN | MIPI DSI Differential Clock Negative |
| 16 | GND | Ground |
| 17 | DOP | MIPI DSI Differential Data Positive |
| 18 | DON | MIPI DSI Differential Data Negative |
| 19 | GND | Ground |
| 20 | GND | Ground |
| - - - END - - - | | |

3.2. 接线说明 Wiring instructions

- 1、将FPC上“R2L”的短接线去掉
Remove the short wire of "R2L" on the FPC
- 2、在FPC上“R1L”贴上0欧姆电阻
Paste an 0 ohm resistor on "R1L" on the FPC

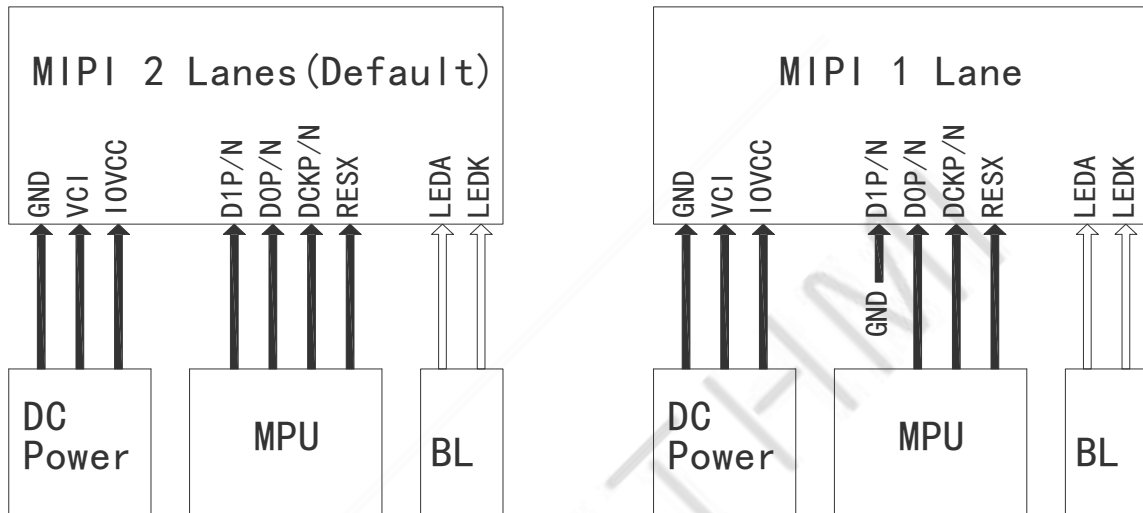

四、电气特性 Electrical Characteristics

4.1. 绝对最大额定值 Absolute Maximum Ratings

| 项目 Item | 标号 Symbol | 条件 Condition | 最小值 Min | 典型值 Type | 最大值 Max | 单位 Unit |
|-------------------------------|--------------|-----------------|------------|-------------|---------------|------------|
| 数字电源 Digital Power | VCI | - | -0.3 | - | 4.0 | 伏 V |
| 接口工作电压 IO Supply Voltage | IOVCC | - | -0.3 | - | 4.0 | 伏 V |
| 输入电压范围 Input Voltage Range | VIN | - | -0.3 | - | IOVCC +0.3 | 伏 V |

注释 Note:

1. 超过上面列出的极限值可能会导致驱动 IC 永久损坏。这些值仅用于测试。IC 应在芯片特性条件下正常运行。如果不满足这些条件，IC 操作可能会出错，可靠性可能会下降。That the exceeds the Limiting Value listed above it may cause the driver IC permanent damage. These values are for test only. IC should be operated under the Chip Characteristic conditions for normal operation. If these conditions are not met, IC operation may be error and the reliability may be deteriorated.
2. 参数在工作温度范围内有效，除非另有说明。除非另有说明，所有电压均相对于 GND。Parameters are valid over operating temperature range unless otherwise specified. All voltages are with respect to GND unless otherwise noted.

4.2. TFT 模组工作条件 TFT LCD Module Operating Conditions

| 项目 Item | 标号 Symbol | 条件 Condition | 最小值 Min | 典型值 Type | 最大值 Max | 单位 Unit |
|-----------------------------|--------------|---------------------|------------|-------------|------------|------------|
| 数字电源 Digital Power | VCI | - | 2.6 | 2.8 | 3.6 | 伏 V |
| 接口工作电压 IO Supply Voltage | IOVCC | - | 1.70 | 1.8 | 3.3 | 伏 V |
| 输入电压 Input Voltage | Vih | | 0.8IOVCC | - | IOVCC | 伏 V |
| | Vi1 | | GND | - | 0.3IOVCC | |
| 待机电流 Standby Current | Isc | No Load@ FR=60Hz | - | - | - | 微安 uA |
| 工作电流 Operation Current | Ioc | | - | - | - | 毫安 mA |

4.3. 背光工作条件 LED back light specification

| 项目 Item | 标号 Symbol | 条件 Condition | 最小值 Min | 典型值 Type | 最大值 Max | 单位 Unit |
|------------------------------------|--------------|-------------------------|------------|-------------|------------|------------------------------|
| 工作电压 Forward voltage | VF | If=3.2V/20mA /1-chip | 22.5 | 25.6 | 27.2 | 伏 V |
| 工作电流 Forward current | IF | | - | 20 | - | 毫安 mA |
| 亮度 (带 LCD) Luminance (With LCD) | Lv | If=20mA | - | 500 | - | 坎德拉/平方米 cd/m ² |
| LED 寿命 LED life time | Hr | Ta=25±3 °C | 20,000 | 30,000 | - | 小时 Hour |

注释 Note:

1. LED 寿命 (Hr) 定义为在 Ta=25±3 °C, 上表所示的典型电压电流值条件下持续工作直至亮度低于 50% 的时间。LED life time (Hr) can be defined as the time in which it continues to operate under the condition: Ta=25±3 °C, typical IL value indicated in the above table until the brightness becomes less than 50%.

2. 以上结果是按MTBF计算方式预估判定的LED失效时间, 实际测试LED在Ta=25±3 °C点亮5000H, 亮度衰减 8%. The above results are estimated and judged by the MTBF calculation method of the LED failure time. The actual test LED is lit for 5000H at Ta=25±3 °C, and the brightness decays by 8%.

五、液晶光学规格 TFT OPTICAL SPECIFICATION

5.1 概述 Overview

光学规格的测试应在暗室（环境亮度 1lux，温度=25 ±2℃）中使用亮度计系统（测角仪系统和TOPCON BM-5）设备进行测量，测试单元应位于大约在 θ 和 Φ 等于 0 的视角下，距 LCD 表面 50cm 的距离。显示面上测量点的中心应保持固定。测量前背光应工作 30 分钟。

The test of Optical specifications shall be measured in a dark room (ambient luminance 1lux and temperature = 25 ±2℃) with the equipment of Luminance meter system (Goniometer system and TOPCON BM-5) and test unit shall be located at an approximate distance 50cm from the LCD surface at a viewing angle of θ and Φ equal to 0. The center of the measuring spot on the Display surface shall stay fixed. The backlight should be operating for 30 minutes prior to measurement.

5.2 光学规格 Optical Specifications

| 参数 Parameter | | 标号 Symbol | 条件 Condition | 最小值 Min. | 典型值 Typ. | 最大值 Max. | 单位 Unit | 备注 Remark |
|--|------------------|--------------|-------------------|-------------|-------------|-------------|------------|-----------------------------|
| 视角范围 Viewing Angle Range | 水平 Horizontal | ⊙左/L | CR>10 | - | 80 | - | Deg. | Note 1 |
| | | ⊙右/R | | - | 80 | - | Deg. | |
| | 垂直 Vertical | ⊙上/U | | - | 80 | - | Deg. | |
| | | ⊙下/D | | - | 80 | - | Deg. | |
| 对比度 Contrast ratio | | CR | ⊙ = 0° | 1000 | 1500 | - | - | Note2 |
| 色域 Color Gamut | | CG | CIE1931 | 60 | 65 | - | % | |
| 白色色度 White Chromaticity | | Wx | ⊙ = 0° | -0.03 | 0.295 | +0.03 | - | Note4 (Based on C Light) |
| | | Wy | | | 0.331 | | - | |
| 色彩还原 Reproduction of color | 红 Red | Rx | | | 0.649 | | - | |
| | | Ry | | | 0.314 | | - | |
| | 绿 Green | Gx | | | 0.263 | | - | |
| | | Gy | | | 0.562 | | - | |
| | 蓝 Blue | Bx | | | 0.137 | | - | |
| | | By | | | 0.111 | | - | |
| 响应时间（上升 + 下降） Response Time (Rising + Falling) | | Tr+Tf | ⊙ = 0° Ta= 25℃ | - | 30 | 40 | ms | Note5 |

注释 Note:

1. 视角是对比度大于10的角度。视角确定为相对于光轴的水平或3、9点钟方向和垂直或6、12点钟方向 垂直于 LCD 表面（见图 1）。

Viewing angle is the angle at which the contrast ratio is greater than 10. The viewing angles are determined for the horizontal or 3, 9 o' clock direction and the vertical or 6, 12 o' clock direction with respect to the optical axis which is normal to the LCD surface (see FIGURE 1).

2. 对比度测量应在 $\theta = 0$ 的视角和 LCD 表面的中心进行。亮度测量时，视场中的所有像素首先设置为白色，然后设置为暗（黑色）状态。（参见图 1）亮度对比度（CR）是通过数学定义的。

Contrast measurements shall be made at viewing angle of $\Theta = 0$ and at the center of the LCD surface. Luminance shall be measured with all pixels in the view field set first to white, then to the dark (black) state. (see FIGUR 1) Luminance Contrast Ratio (CR) is defined mathematically.

$$CR = \frac{\text{Luminance when displaying a white raster}}{\text{Luminance when displaying a black raster}}$$

3. 透射率是没有 APF 和没有 CG 的值。

Transmittance is the Value without APF and without CG.

4. 上表中规定的色度坐标应由所有像素首先测量的光谱数据计算为红色、绿色、蓝色和白色。测量应在面板的中心进行。

The color chromaticity coordinates specified in the above table shall be calculated from the spectral data measured with all pixels first in red, green, blue and white. Measurements shall be made at the center of the panel.

5. 电光响应时间测量应如图 2 所示，通过打开和关闭“数据”输入信号来进行。亮度从 10%变化到90%所需的时间是 T_r ，90%到10%是 T_f 。

The electro-optical response time measurements shall be made as FIGURE 2 by switching the “data” input signal ON and OFF. The times needed for the luminance to change from 10% to 90% is T_r , and 90% to 10% is T_f .

Figure1 Measurement Set Up



图 1



图 2

六、时序 Timing

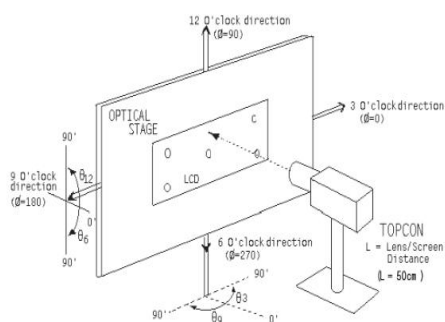
6.1. 直流特性 DC Characteristics

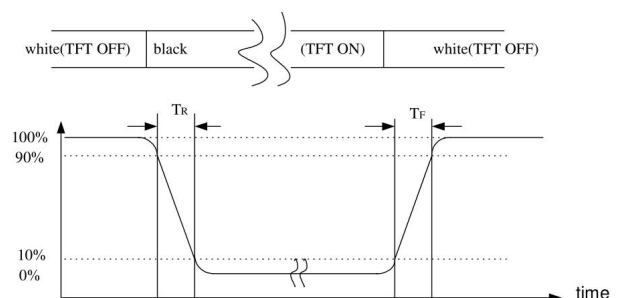
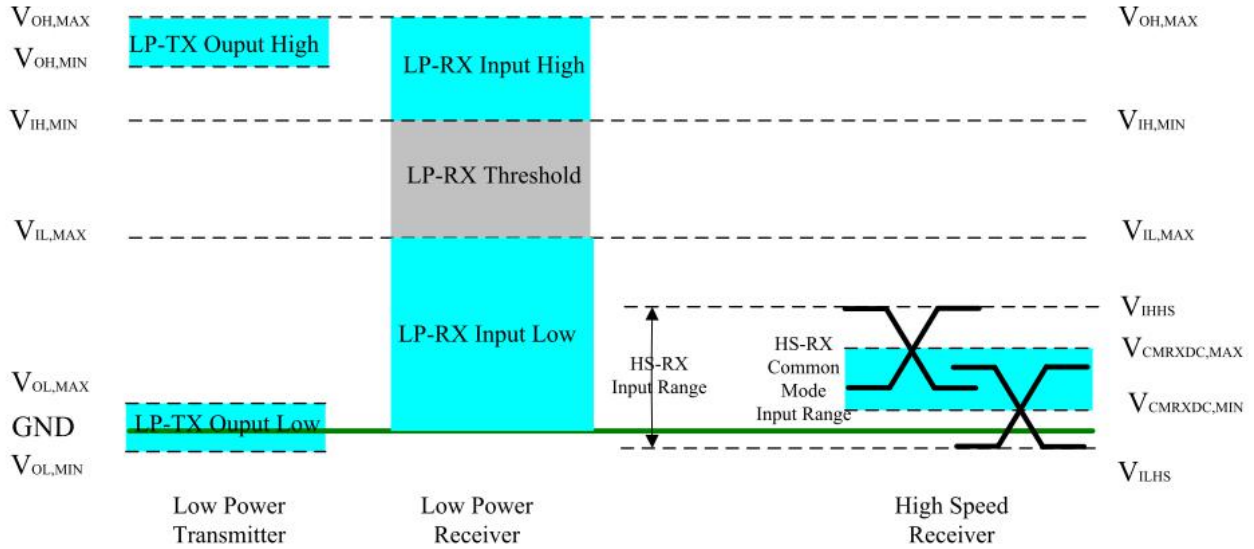

$V_{DDI}=1.8, V_{DD}=2.8, AGND=DGND=0V, T_a=25\text{ }^{\circ}\text{C}$

| Parameter | Symbol | Specification | | | Unit |
|--|--------------|---------------|-----|------|------|
| | | MIN | TYP | MAX | |
| Operation Voltage for MIPI Receiver | | | | | |
| Low power mode operating voltage | V_{LPH} | 1.1 | 1.2 | 1.3 | V |
| MIPI Characteristics for High Speed Receiver | | | | | |
| Single-ended input low voltage | V_{ILHS} | -40 | - | - | mV |
| Single-ended input high voltage | V_{IHHS} | - | - | 460 | mV |
| Common-mode voltage | V_{CMRXDC} | 70 | - | 330 | mV |
| Differential input impedance | Z_{ID} | 80 | 100 | 125 | ohm |
| MIPI Characteristics for Low Power Mode | | | | | |
| Pad signal voltage range | V_I | -50 | - | 1350 | mV |
| Logic 0 input threshold | V_{IL} | 0- | - | 550 | mV |
| Logic 1 input threshold | V_{IH} | 880 | - | 1350 | mV |
| Output low level | V_{OL} | -50 | - | 50 | mV |
| Output high level | V_{OH} | 1.1 | 1.2 | 1.3 | V |

6.2. 交流特性 AC Characteristics

6.2.1. 高速模式 High Speed Mode



Figure-1 DSI clock channel timing

$V_{DDI}=1.8, V_{DD}=2.8, AGND=DGND=0V, T_a=25\text{ }^{\circ}\text{C}$

| Signal | Symbol | Parameter | MIN | MAX | Unit | Description |
|------------|------------------------------|--------------------------|------|------|------|--------------------------------|
| DSI-CLK+/- | $2xUI_{INSTA}$ | Double UI instantaneous | 4 | 25 | ns | |
| DSI-CLK+/- | UI_{INSTA} UI_{INSTB} | UI instantaneous halves | 2 | 12.5 | ns | $UI = UI_{INSTA} = UI_{INSTB}$ |
| DSI-Dn+/- | t_{DS} | Data to clock setup time | 0.15 | - | UI | |
| DSI-Dn+/- | t_{DH} | Data to clock hold time | 0.15 | - | UI | |

Table-1 Mipi Interface- High Speed Mode Timing Characteristics

6.2.2. 低速模式 Low Power Mode

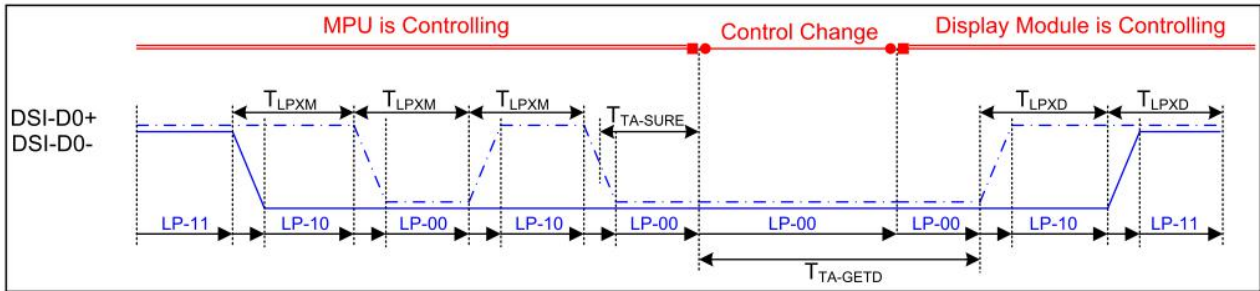

Figure-2 Bus Turnaround (BTA) from display module to MPU Timing

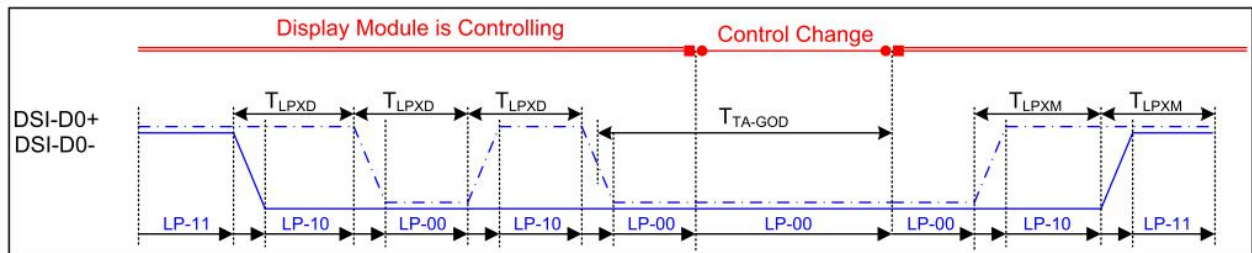

Figure-3 Bus Turnaround (BTA) from MPU to display module Timing

$VDDI=1.8, VDD=2.8, AGND=DGND=0V, Ta=25\text{ }^{\circ}\text{C}$

| Signal | Symbol | Parameter | MIN | MAX | Unit | Description |
|-----------|-----------|--|------------|---------------------|------|-------------|
| DSI-D0+/- | TLPXM | Length of LP-00, LP-01, LP-10 or LP-11 periods MPU→Display Module | 50 | 75 | ns | Input |
| DSI-D0+/- | TLPXD | Length of LP-00, LP-01, LP-10 or LP-11 periods MPU→Display Module | 50 | 75 | ns | Output |
| DSI-D0+/- | TTA-SURED | Time-out before the MPU start driving | T_{LPXD} | $2 \times T_{LPXD}$ | ns | Output |
| DSI-D0+/- | TTA-GETD | Time to drive LP-00 by display module | | $5 \times T_{LPXD}$ | ns | Input |
| DSI-D0+/- | TTA-GOD | Time to drive LP-00 after turnaround request-MPU | | $4 \times T_{LPXD}$ | ns | Output |

Table-2 Mipi Interface Low Power Mode Timing Characteristics

6.2.3. DSI 突发模式 DSI Bursts Mode

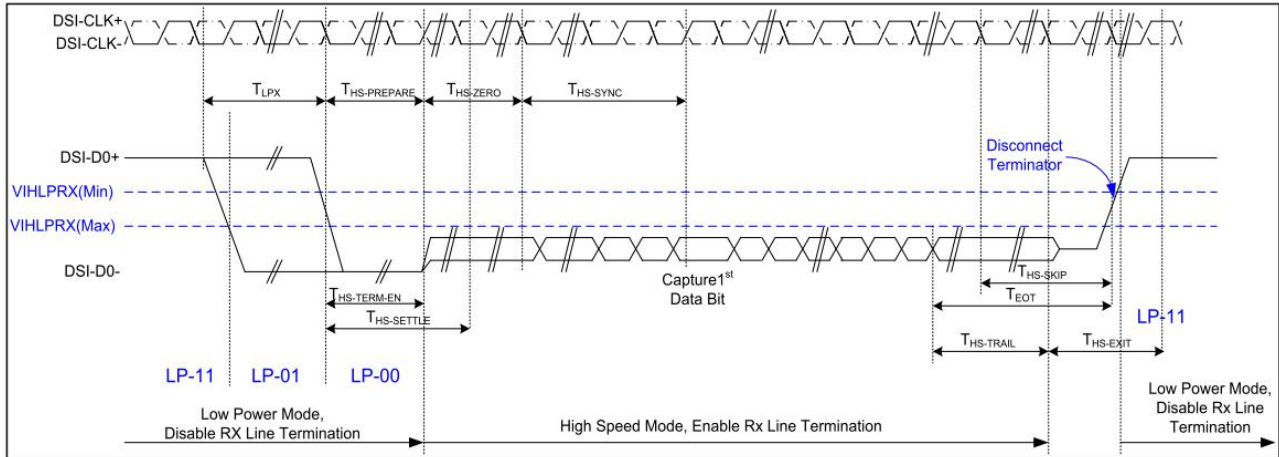

Figure-4 Data lanes-Low Power Mode to/from High Speed Mode Timing

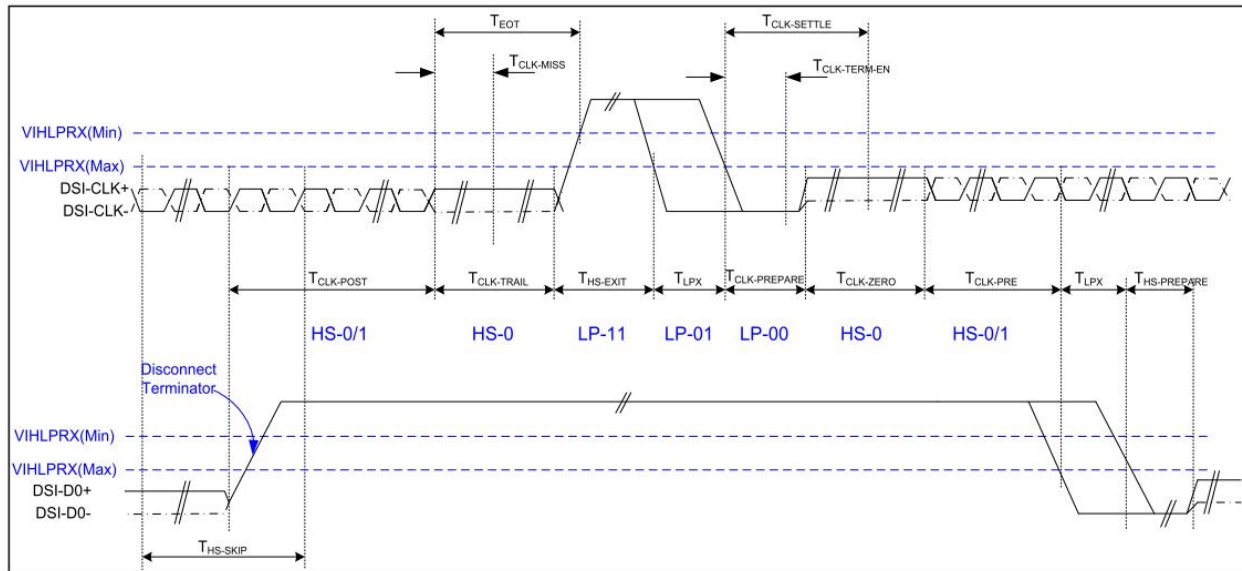
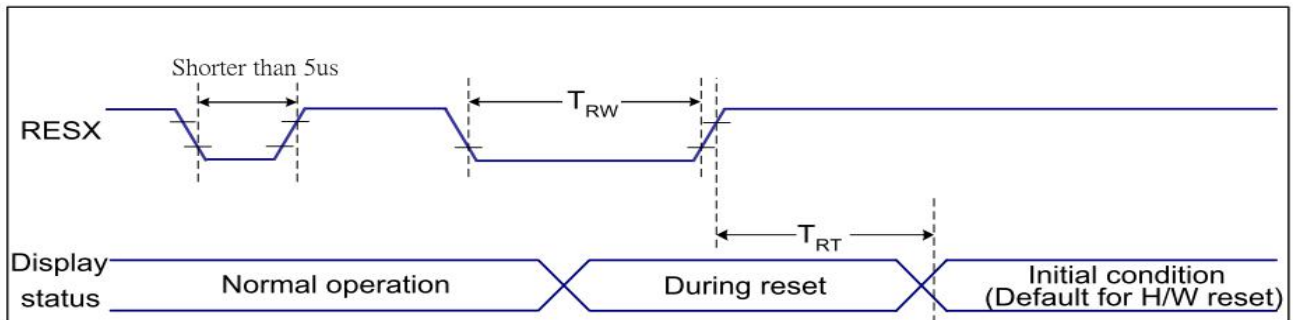

Figure-5 Clock lanes- High Speed Mode to/from Low Power Mode Timing

VDDI=1.8, VDD=2.8, AGND=DGND=0V, Ta=25 °C

| Signal | Symbol | Parameter | MIN | MAX | Unit | Description |
|---|--------------------------|--|--------------|--------------------|------|-------------|
| Low Power Mode to High Speed Mode Timing | | | | | | |
| DSI-Dn+/- | TLPX | Length of any low power state period | 50 | - | ns | Input |
| DSI-Dn+/- | THS-PREPARE | Time to drive LP-00 to prepare for HS transmission | 40+4 UI | 85+6 UI | ns | Input |
| DSI-Dn+/- | THS-TERM-EN | Time to enable data receiver line termination measured from when Dn crosses VILMAX | - | 35+4 UI | ns | Input |
| DSI-Dn+/- | THS-PREPARE + THS-ZERO | THS-PREPARE + time to drive HS-0 before the sync sequence | 140+ 10UI | - | ns | Input |
| High Speed Mode to Low Power Mode Timing | | | | | | |
| DSI-Dn+/- | THS-SKIP | Time-out at display module to ignore transition period of EoT | 40 | 55+4 UI | ns | Input |
| DSI-Dn+/- | THS-EXIT | Time to drive LP-11 after HS burst | 100 | - | ns | Input |
| DSI-Dn+/- | THS-TRAIL | Time to drive flipped differential state after last payload data bit of a HS transmission burst | 60+4 UI | - | ns | Input |
| High Speed Mode to/from Low Power Mode Timing | | | | | | |
| DSI-CLK+/- | TCLK-POS | Time that the MPU shall continue sending HS clock after the last associated data lane has transition to LP mode | 60+5 2UI | - | ns | Input |
| DSI-CLK+/- | TCLK-TRAIL | Time to drive HS differential state after last payload clock bit of a HS transmission burst | 60 | - | ns | Input |
| DSI-CLK+/- | THS-EXIT | Time to drive LP-11 after HS burst | 100 | - | ns | Input |
| DSI-CLK+/- | TCLK-PREPARE | Time to drive LP-00 to prepare for HS transmission | 38 | 95 | ns | Input |
| DSI-CLK+/- | TCLK-TERM-EN | Time-out at clock lan display module to enable HS transmission | -- | 38 | ns | Input |
| DSI-CLK+/- | TCLK-PREPARE + TCLK-ZERO | Minimum lead HS-0 drive period before starting clock | 300 | - | ns | Input |
| DSI-CLK+/- | TCLK-PRE | Time that the HS clock shall be driven prior to any associated data lane beginning the transition from LP to HS mode | 8UI | - | ns | Input |
| DSI-CLK+/- | TEOT | Time form start of TCLK-TRAIL period to start of LP-11 state | - | 105n s+12 UI | ns | Input |

6.3. 复位时序 Reset Timing



VDDI=1.8, VDD=2.8, AGND=DGND=0V, Ta=25 °C

| Related Pins | Symbol | Parameter | MIN | MAX | Unit |
|--------------|--------|----------------------|-----|--------------------|------|
| RESX | TRW | Reset pulse duration | 10 | - | us |
| | TRT | Reset cancel | - | 5 (Note 1, 5) | ms |
| | | | | 120 (Note 1, 6, 7) | ms |

Notes:

- The reset cancel includes also required time for loading ID bytes, VCOM setting and other settings from NVM (or similar device) to registers. This loading is done every time when there is HW reset cancel time (t_{RT}) within 5 ms after a rising edge of RESX.
- Spike due to an electrostatic discharge on RESX line does not cause irregular system reset according to the table below:

| RESX Pulse | Action |
|---------------------|----------------|
| Shorter than 5us | Reset Rejected |
| Longer than 9us | Reset |
| Between 5us and 9us | Reset starts |

- During the Resetting period, the display will be blanked (The display is entering blanking sequence, which maximum time is 120 ms, when Reset Starts in Sleep Out - mode. The display remains the blank state in Sleep In - mode.) and then return to Default condition for Hardware Reset.

- Spike Rejection also applies during a valid reset pulse as shown below:

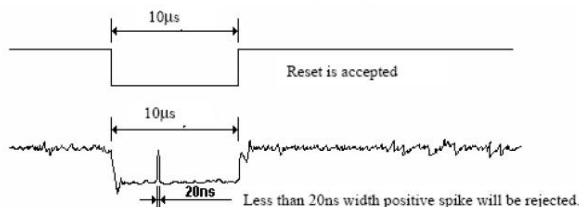

- When Reset applied during Sleep In Mode.
- When Reset applied during Sleep Out Mode.
- It is necessary to wait 5msec after releasing RESX before sending commands. Also Sleep Out command cannot be sent for 120msec.

6.4. 开机上电顺序/Power-on sequence

IOVCC 和 VCI 可以按任何顺序应用或断电。在关机序列期间,如果 LCD 处于休眠模式,则 VCI 和 IOVCC 必须在至少 120 毫秒内断电。如果 LCD 处于休眠模式,VCI 和 IOVCC 可以在 RESX 释放后至少 0 毫秒内断电。CSX 可以在任何时间应用,也可以永久接地。RESX 的优先级高于 CSX。

IOVCC and VCI can be applied or powered down in any order. During the Power Off sequence, if the LCD is in the Sleep Out mode, VCI and IOVCC must be powered down with minimum 120msec. If the LCD is in the Sleep In mode, VCI and IOVCC can be powered down with minimum 0msec after the RESX is released. CSX can be applied at any timing or can be permanently grounded. RESX has high priority over CSX.

备注 Notes:

1. 如果不满足电源顺序,ST7701S 不会损坏。There will be no damage to the ST7701S if the power sequences are not met.

2. 在电源开/关序列期间,显示面板上不会有异常的可见效果。There will be no abnormal visible effects on the display panel during the Power On/Off Sequences.

3. 在 Power On Sequence 结束和收到 Sleep Out 命令之前,以及在收到 Sleep In 命令和 Power Off Sequence 之间,显示屏上不会出现异常可见的效果。There will be no abnormal visible effects on the display between the end of Power On Sequence and before receiving the Sleep Out command, and also between receiving the Sleep In command and the Power Off Sequence.

4. 如果在第 6.4.1 节中定义的开机序列期间主机没有稳定地保持 RESX 线,则有必要在主机开机序列完成后应用硬件复位 (RESX) 以确保正确的操作。否则,无法保证所有功能。(修改后)恢复原文 If the RESX line is not steadily held by the host during the Power On Sequence as defined in Sections 6.4.1, then it will be necessary to apply the Hardware Reset (RESX) after the completion of the Host Power On Sequence to ensure correct operations. Otherwise, all the functions are not guaranteed.

6.4.1. 不受控制的断电 Uncontrolled Power Off

非受控断电是指在没有受控断电序列的情况下取出电池的情况。它不会损坏模块或主机接口。The uncontrolled power-off means a situation which removed a battery without the controlled power off sequence. It will neither damage the module or the host interface.

如果发生不受控制的断电,显示屏将变为空白,显示屏上不会有任何可见效果(空白显示)并保持空白,直到“Power On Sequence”启动它。If uncontrolled power-off happened, the display will go blank and there will not any visible effect on the display (blank display) and remains blank until “Power On Sequence” powers it up.

电源开/关顺序如下图所示 The power on/off sequence is illustrated below

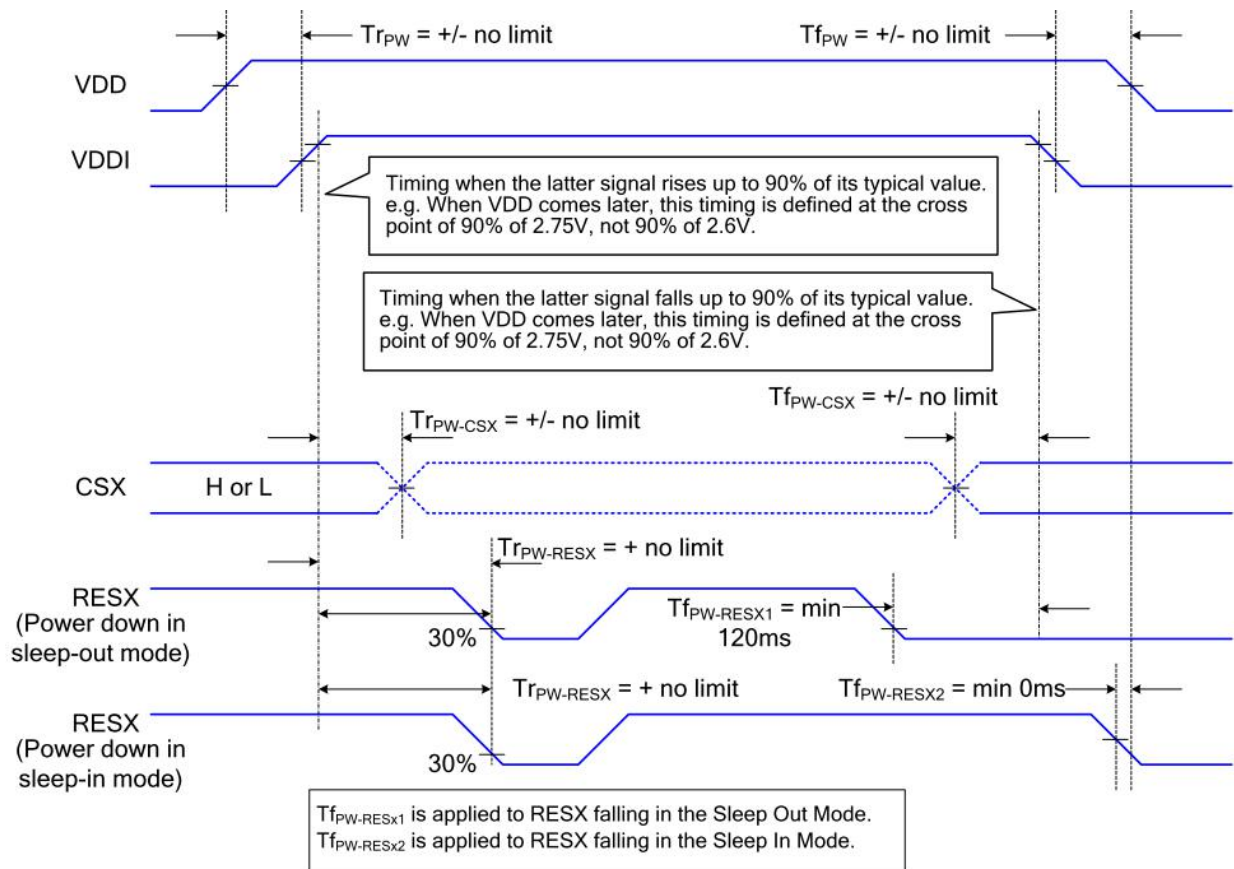

七、可靠性测试 RELIABILITY TEST

7-1 温度和湿度 Temperature and Humidity

| 测试项目 TEST ITEMS | 条件 CONDITIONS | 注释 NOTE |
|--|------------------------------|------------|
| 高温储存 High Temperature Storage | Ta=+80°C, 120hrs | |
| 低温储存 Low Temperature Storage | Ta=-30 °C, 120hrs | |
| 高温运行试验 High Temperature Operation | Ta=+80 °C, 120hrs | |
| 低温运行试验 Low Temperature Operation | Ta=-30 °C, 120hrs | |
| 高温高湿（运行测试） High Temperature and High Humidity (Operating) | Ta=+60 °C, 90%RH Max, 120hrs | |

注释 Note:

1. 液晶驱动电压。由于液晶材料的特性，该电压随环境温度而变化。Liquid Crystal driving voltage. Due to the characteristics of LC Material, this voltage varies with environmental temperature.

2. 温度和相对湿度范围如下图所示。湿球温度最高应为39°C。并且没有冷凝水。Temperature and relative humidity range are shown in the figure below. Wet bulb temperature should be 39 °C max. and no condensation of water.

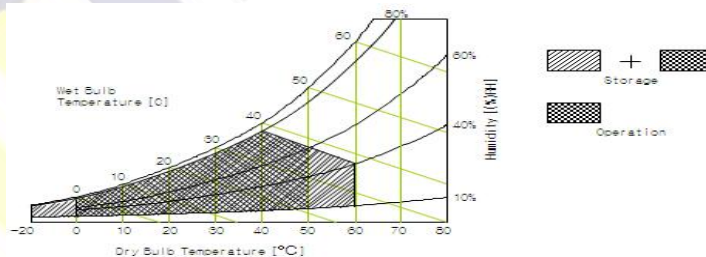

3. 产品经可靠性测试后，仅保证功能正常，无任何致命缺陷（不显示、线路缺陷、显示异常等）。After the reliability test, the product only guarantee function normally without any fatal defect(non-display, line defect, abnormal display etc).

4. 所有显示判断均在面板温度恢复到室温两小时后进行 All display judgments are performed two hours after the panel temperature returns to room temperature

5. Ta: 环境温度 Ambient temperature

7-2 冲击和振动 Shock and Vibration

| 测试项目 TEST ITEMS | 条件 CONDITIONS |
|---|---|
| 包装冲击(非操作) Packing Shock (Non-Operation) | <ul style="list-style-type: none"> ● Shock level:980m/s² ● Waveform:1/2 Sine wave,6msec ● ±X, ±Y ±Z, each axis 1 times |
| 包装振动(非操作) Packing Vibration (Non-Operation) | <ul style="list-style-type: none"> ● Frequency range:8-33.3HZ ● Stoke:1.0mm ● Sweep: 10Hz-50Hz ● x, y, z 2 hours for each direction |

7-3 静电放电测试 Electrostatic Discharge

| 测试项目 TEST ITEMS | 条件 CONDITIONS |
|------------------------|--|
| ESD (Non-operation) | 150pF, 330 Ω, Contact ±2KV, Air : ±4KV. Note 1 |
| | 200pF, 0 Ω, ±200V Contact test. Note 2 |

测量点 Measure Point:

1. LCD玻璃和金属边框 LCD glass and metal bezel
2. 连接器引脚 IF connector pins

八、处理和注意事项 HANDLING & CAUTIONS

8-1 操作注意事项 Caution For Operation

◆由于液晶模组是玻璃材质，请勿对其施加强烈的机械冲击或静载荷。请小心搬运，因为冲击、振动和粗心的搬运可能会严重影响产品。如果从高处坠落或受到强烈冲击，玻璃可能碎了。

Since the LCM is made of glass, do not apply strong mechanical impact or static load onto it. Handling with care since shock, vibration, and careless handling may seriously affect the product. If it falls from a high place or receives a strong shock, the glass maybe broken.

◆在规定的电压限制内驱动 LCM 是必不可少的，因为高于限制的电压会导致 LCM 的寿命缩短。由直流引起的电化学反应会导致 LCM 出现不良劣化，因此应避免使用直流驱动。

It is indispensable to drive the LCM within the specified voltage limit since the higher voltage than the limit causes LCM's life shorter. An electro-chemical reaction due to DC causes undesirable deterioration of the LCM so that the use of DC drive should avoid.

◆请勿在电源开启时将 LCM 连接到系统或从系统断开连接。

Do not connect or disconnect the LCM to or from the system when power is on.

◆切勿在高温高湿的异常条件下使用 LCM。

Never use the LCM under abnormal conditions of high temperature and high humidity.

◆当暴露于剧烈的温度波动（热到冷或冷到热）时，LCM可能会受到影响；具体来说，从冷到热的剧烈温度波动会在 LCM 表面产生露水，这可能会影响 LCM 上偏振片的运行。

When expose to drastic fluctuation of temperature (hot to cold or cold to hot), the LCM may be affected; specifically, drastic temperature fluctuation from cold to hot, produces dew on the LCM's surface which may affect the operation of the polarizer on the LCM.

◆在低于工作温度范围的温度下，响应时间将极度延迟，另一方面，在高于其工作范围的温度下，LCM 可能会变黑。然而，这些现象并不意味着 LCM 出现故障或故障。一旦温度恢复到正常运行的推荐温度范围，LCM 将恢复正常运行。

Response time will be extremely delay at lower temperature than the operating temperature range and on the other hand LCM may turn black at temperature above its operational range. However those phenomenon do not mean malfunction or out of order with the LCM. The LCM will revert to normal operation once the temperature returns to the recommended temperature range for normal operation.

◆为防止LCD产生图像残留，在使用常黑面板时不要长时间显示固定图案。如果LCD需要显示固定图案，建议时间少于 2 分钟或者更短的时间内刷新显示内容一次或多次。强烈建议使用黑色图像或移动图像作为屏幕保护程序。

In order to prevent the LCD from producing image retention, do not display a fixed pattern for a long time when using a normally black panel. If the LCD needs to display a fixed pattern, it is recommended to refresh the display one or more times in less

than 2 minutes or less. It is strongly recommended to use a black image or moving image as a screen saver.

8-2 防静电措施 Caution Against Static Charge

◆LCM 使用 C-MOS LSI 驱动器，因此建议客户将任何未使用的输入端连接到 Vdd 或 Vss，上电前不要输入任何信号，并将您的身体、工作/装配区、装配设备接地 防止静电。

The LCM use C-MOS LSI drivers, so customers are recommended that any unused input terminal would be connected to Vdd or Vss, do not input any signals before power is turn on, and ground you body, work/assembly area, assembly equipments to protect against static electricity.

◆缓慢去除保护膜，保持去除方向与面板表面不垂直约 30 度，如有可能，在离子风机等 ESD 控制装置下，工作室湿度应保持在 50%RH 以上，以减少静电风险

Remove the protective film slowly, keeping the removing direction approximate 30-degree not vertical from panel surface, if possible, under ESD control device like ion blower, and the humidity of working room should be kept over 50%RH to reduce the risk of static charge.

◆避免使用合成纤维制成的工作服。我们推荐棉质衣服或其他经过导电处理的纤维。

Avoid the use work clothing made of synthetic fibers. We recommend cotton clothing or other conductivity-treated fibers.

◆在处理 LCM 时，请戴上不带电材料的手套。对地导电手腕和对地导电鞋是必需的

In handling the LCM, wear non-charged material gloves. And the conducting wrist to the earth and the conducting shoes to the earth are necessary

九、初始化代码 LCD display initialization code

```

Void Panel_Initial_code(void)
{
//TFT分辨率: 400 x 960
//测试接口: MIPI 2L
//测试板主控:
//Power:VCI=2.8, IOVCC=1.8

//#define HT HFP+HBP+HPW
//#define HFP 40
//#define HBP 50
//#define HPW 8

//#define VT VFP+VBP+VPW
//#define VFP 20
//#define VBP 20
//#define VPW 8

//External system porch setting:125>VBP ≥10, VFP ≥10
//Line Time: 16.6 uS
//Frame Rate: 59.8 Hz
//Pixel Clk: 30 MHz

//=====上电复位操作=====//
LCD_RESET=1;
Delays(1); //Delay 1ms
LCD_RESET=0;
Delays(10); //Delay 10ms
LCD_RESET=1;
Delays(120); //Delay 120ms
//=====//

WriteComm (0xFF);
WriteData (0x77);
WriteData (0x01);
WriteData (0x00);
WriteData (0x00);
WriteData (0x13);
WriteComm (0xEF);
WriteData (0x08);
    
```

WriteComm (0xFF);
WriteData (0x77);
WriteData (0x01);
WriteData (0x00);
WriteData (0x00);
WriteData (0x10);
WriteComm (0xC0);
WriteData (0x77);
WriteData (0x00);
WriteComm (0xC1);
WriteData (0x0E);
WriteData (0x0C);
WriteComm (0xC2);
WriteData (0x07);
WriteData (0x02);
WriteComm (0xCC);
WriteData (0x30);
WriteComm (0xB0);
WriteData (0x00);
WriteData (0x13);
WriteData (0x1E);
WriteData (0x0D);
WriteData (0x11);
WriteData (0x06);
WriteData (0x0F);
WriteData (0x07);
WriteData (0x0F);
WriteData (0x2C);
WriteData (0x05);
WriteData (0x17);
WriteData (0x1E);
WriteData (0x2D);
WriteData (0x34);
WriteData (0x1D);
WriteComm (0xB1);
WriteData (0x00);
WriteData (0x1A);
WriteData (0x1F);
WriteData (0x0F);
WriteData (0x12);

WriteData (0x08);
WriteData (0x0B);
WriteData (0x0A);
WriteData (0x03);
WriteData (0x22);
WriteData (0x03);
WriteData (0x0F);
WriteData (0x09);
WriteData (0x28);
WriteData (0x33);
WriteData (0x1F);
WriteComm (0xFF);
WriteData (0x77);
WriteData (0x01);
WriteData (0x00);
WriteData (0x00);
WriteData (0x11);
WriteComm (0xB0);
WriteData (0x5C);
WriteComm (0xB1);
WriteData (0x69);
WriteComm (0xB2);
WriteData (0x87);
WriteComm (0xB3);
WriteData (0x80);
WriteComm (0xB5);
WriteData (0x4A);
WriteComm (0xB7);
WriteData (0x85);
WriteComm (0xB8);
WriteData (0x48);
WriteComm (0xB9);
WriteData (0x10);
WriteData (0x1F);
WriteComm (0xBB);
WriteData (0x03);
WriteComm (0xC0);
WriteData (0x80);
WriteComm (0xC1);
WriteData (0x08);

WriteComm (0xC2);
WriteData (0x08);
WriteComm (0xD0);
WriteData (0x88);
WriteComm (0xE0);
WriteData (0x00);
WriteData (0x00);
WriteData (0x02);
WriteData (0x00);
WriteData (0x00);
WriteData (0x0C);
WriteComm (0xE1);
WriteData (0x03);
WriteData (0x96);
WriteData (0x05);
WriteData (0x96);
WriteData (0x02);
WriteData (0x96);
WriteData (0x04);
WriteData (0x96);
WriteData (0x00);
WriteData (0x44);
WriteData (0x44);
WriteComm (0xE2);
WriteData (0x00);
WriteData (0x00);
WriteData (0x03);
WriteData (0x03);
WriteData (0x00);
WriteData (0x00);
WriteData (0x02);
WriteData (0x00);
WriteData (0x00);
WriteData (0x00);
WriteData (0x02);
WriteData (0x00);
WriteData (0x00);
WriteComm (0xE3);
WriteData (0x00);
WriteData (0x00);
WriteData (0x33);

WriteData (0x33);
WriteComm (0xE4);
WriteData (0x44);
WriteData (0x44);
WriteComm (0xE5);
WriteData (0x0B);
WriteData (0xD4);
WriteData (0x28);
WriteData (0x8C);
WriteData (0x0D);
WriteData (0xD6);
WriteData (0x28);
WriteData (0x8C);
WriteData (0x07);
WriteData (0xD0);
WriteData (0x28);
WriteData (0x8C);
WriteData (0x09);
WriteData (0xD2);
WriteData (0x28);
WriteData (0x8C);
WriteComm (0xE6);
WriteData (0x00);
WriteData (0x00);
WriteData (0x33);
WriteData (0x33);
WriteComm (0xE7);
WriteData (0x44);
WriteData (0x44);
WriteComm (0xE8);
WriteData (0x0A);
WriteData (0xD5);
WriteData (0x28);
WriteData (0x8C);
WriteData (0x0C);
WriteData (0xD7);
WriteData (0x28);
WriteData (0x8C);
WriteData (0x06);
WriteData (0xD1);

WriteData (0x28);
WriteData (0x8C);
WriteData (0x08);
WriteData (0xD3);
WriteData (0x28);
WriteData (0x8C);
WriteComm (0xEB);
WriteData (0x00);
WriteData (0x01);
WriteData (0xE4);
WriteData (0xE4);
WriteData (0x44);
WriteData (0x00);
WriteComm (0xED);
WriteData (0xFF);
WriteData (0x45);
WriteData (0x67);
WriteData (0xFC);
WriteData (0x01);
WriteData (0x3F);
WriteData (0xAB);
WriteData (0xFF);
WriteData (0xFF);
WriteData (0xBA);
WriteData (0xF3);
WriteData (0x10);
WriteData (0xCF);
WriteData (0x76);
WriteData (0x54);
WriteData (0xFF);
WriteComm (0xEF);
WriteData (0x10);
WriteData (0x0D);
WriteData (0x04);
WriteData (0x08);
WriteData (0x3F);
WriteData (0x1F);
WriteComm (0xFF);
WriteData (0x77);
WriteData (0x01);

```
WriteData (0x00);  
WriteData (0x00);  
WriteData (0x13);  
WriteComm (0xE8);  
WriteData (0x00);  
WriteData (0x0E);  
WriteComm (0x11);  
Delay_ms(120);  
WriteComm (0xE8);  
WriteData (0x00);  
WriteData (0x0C);  
Delay_ms(20);  
WriteComm (0xE8);  
WriteData (0x40);  
WriteData (0x00);  
WriteComm (0xFF);  
WriteData (0x77);  
WriteData (0x01);  
WriteData (0x00);  
WriteData (0x00);  
WriteData (0x00);  
WriteComm (0x36);  
WriteData (0x00);  
WriteComm (0x35);  
WriteData (0x00);  
Delay_ms(120);  
  
WriteComm (0x29);  
Delay_ms(120);  
  
}
```

```
Void ST7701S_Sleep in (void)
{
WriteComm (0x28); //Enter display off
Delays (120); //Delay 120ms
WriteComm (0x10); //Enter sleep in
}
```

```
Void ST7701S_Sleep out (void)
{
WriteComm (0x11); //Enter sleep out
Delays (120); //Delay 120ms
WriteComm (0x29); //Enter display on
}
```

---END---