

LCM Specification

Preliminary specification

Final Specification

Project No. 项目编号	TFT-H043A4WVIST5N60		
Customer 客户名称			
Module No. 客户型号			
Product type 产品内容	TFT LCD Module 480 x 3RGB x 800 Dots 4.3" TFT LCD		
Signature by customer: 客户确认签章:			
<input type="checkbox"/> Trial production		<input type="checkbox"/> Mass production	
编 制	电子审核	结构审核	批 准
Liu.YL			

1 Document revision history :

DOCUMENT REVISION	DATE	DESCRIPTION	PREPARED BY	APPROVED BY
0	2019-5-15	First Release.	Liu.YL	
1	2020-04-09	Update product drawings	Liu.YL	

1. General Feature:

Item	Standard Value	Unit
Display Size	4.3"	--
Number of Pixels	480(H)x3(RGB)*800(V)	--
Active Area	56.16(H) *93.60(V)	mm
LCM Outline Dimension	60.86(H) ×102.57× 2.70(V)	mm
Viewing Direction	Full O'Clock	-
LCM Interface	With CPU / RGB / MIPI / MDDI Interface	-
LCM Driver IC	NT35510	-
LCM Driver Voltage	IOVCC=1.8V,VCI=3.3V (Typ)	V
Backlight	White LED	-
Touch Panel	Without Touch Panel	-
CTP Driver IC	---	-
CTP Driver Voltage	---	V
CTP I/O Digital Voltage	---	V
Operation Temperature	-20~70	°C
Storage Temperature	-30~80	°C

2.Outline Dimensions

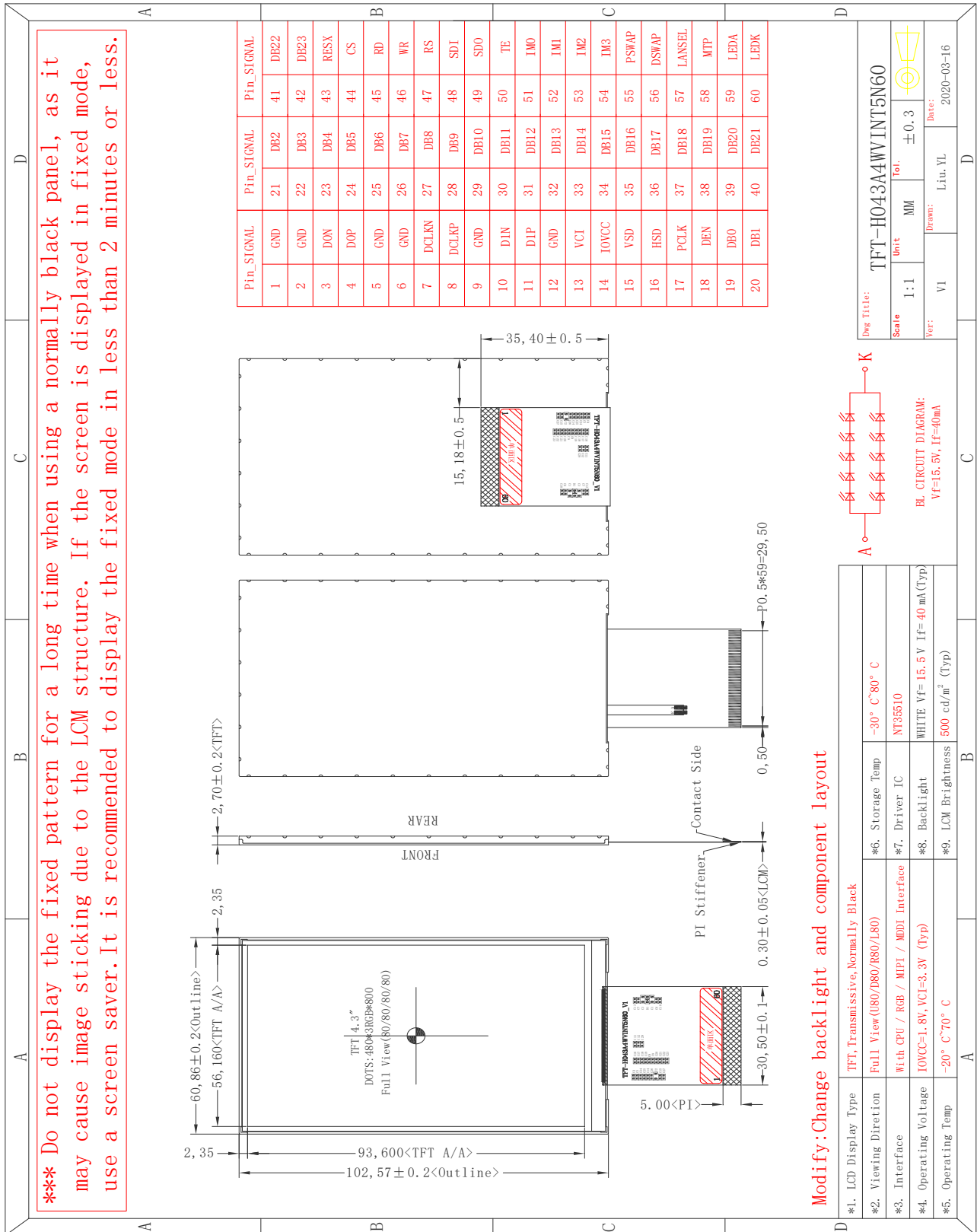

3. Pin Description

3.1 Pin Description

Pin NO.	Symbol	Description
1, 2	GND	Ground
3	DON	◆These pins are DSI-D0+/- differential data signals if MIPI interface is used.
5	DOP	◆These pins are MDDI_DATA0_P/M differential strobe signals if MDDI interface is used. ◆If not used, please fix this pin at GND.
5, 6	GND	Ground
7	DCLKN	◆These pins are DSI-CLK+/- differential clock signals if MIPI interface is used.
8	DCLKP	◆These pins are MDDI_STB_P/M differential strobe signals if MDDI interface is used. ◆If not used, please fix this pin at GND.
9	GND	Ground
10	D1N	◆These pins are DSI-D1+/- differential data signals if MIPI interface is used.
11	D1P	◆These pins are MDDI_DATA1_P/M differential strobe signals if MDDI interface is used. ◆If not used, please fix this pin at GND.
12	GND	Ground
13	VCI	Analog Power
14	IOVCC	Power supply for interface system
15	VSD	◆ Vertical synchronizing input signal for RGB interface. ◆ If not used, please fix this pin at GND.
16	HSD	◆ Horizontal synchronizing input signal for RGB interface. ◆ If not used, please fix this pin at GND.
17	PCLK	◆ Pixel clock signal for RGB interface. ◆ If not used, please fix this pin at GND.
18	DEN	◆ Data enable signal for RGB interface. ◆ If not used, please fix this pin at GND.
19-42	DB0-DB23	◆ Data Bus. ◆ If not used, please fix this pin at GND.
43	RESET	LCM Reset Pin.
44	CSX	◆ Chip select input pin (“Low” enable) in 80-series MPU I/F and SPI I/F. ◆ This pin is not used for MIPI or MDDI I/F, please fix this pin at GND.

Pin NO.	Symbol	Description
45	RDX	<ul style="list-style-type: none"> ◆ Read enable in 8080 MCU parallel IF. Low-active. ◆ If not used, please fix this pin at GND.
46	WRX	<ul style="list-style-type: none"> ◆ Write enable in MCU parallel interface ◆ In SPI mode, this pin is used as SCL. ◆ In I2C mode, Serial input clock in I2C I/F ◆ If not used, please fix this pin at GND.
47	DCX	<ul style="list-style-type: none"> ◆ Display data/command selection pin in parallel IF. ◆ If not used, please fix this pin at GND.
48	SPI_SDI	<ul style="list-style-type: none"> ◆ In SPI mode, SPI interface input/output pin. ◆ In I2C mode, Serial input/output signal in I2C I/F. ◆ If not used, please fix this pin at GND.
49	SPI_SDO	<ul style="list-style-type: none"> ◆ In SPI mode, SPI interface output pin. ◆ If not used, please let this pin open.
50	TE	<ul style="list-style-type: none"> ◆ Tearing effect signal is used to synchronize MCU to frame memory writing. ◆ If not used, please let this pin open.
51-54	IMO-IM3	The MCU interface mode select
55	PSWAP	<ul style="list-style-type: none"> ◆ Input pin to select HSSI_D0/D1 data lane sequence and polarity in high speed interface only. ◆ For MIPI interface, both DSWAP and PSWAP function are available.
56	DSWAP	<ul style="list-style-type: none"> ◆ For MDDI interface, only PSWAP function is available. i.e. DSWAP=1 in below table is invalid. ◆ If not used, please fix this pin at GND.
57	LANSEL	<ul style="list-style-type: none"> ◆ Input pin to select 1 data lane or 2 data lanes in MIPI/MDDI interface. ◆ If not used, please fix this pin at GND.
58	MTP	No Conect
59	LED_A	LED Anode
60	LED_K	LED Cathode

-- END --

3.2 Wiring Diagram

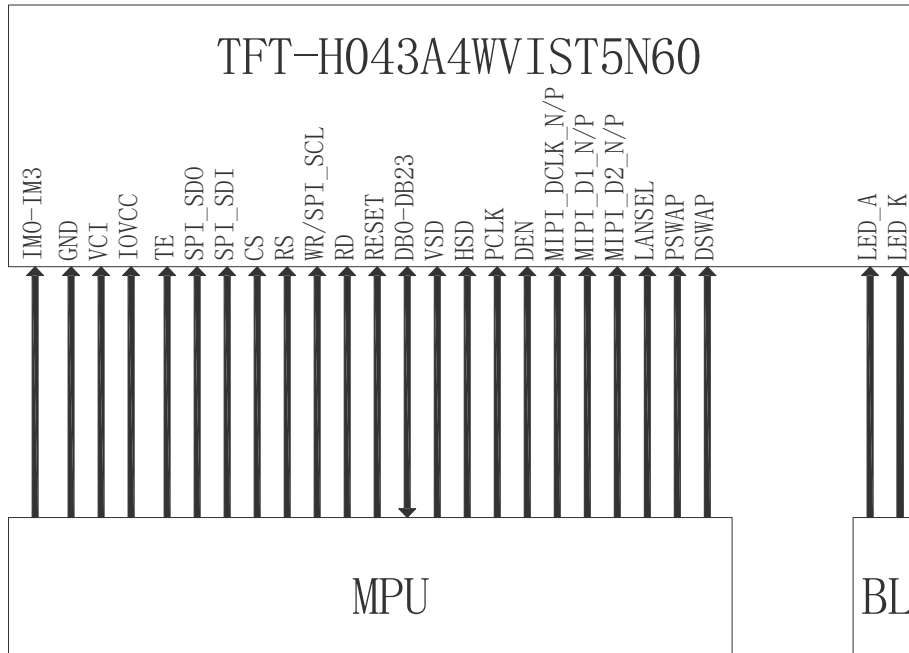

*Interface definition by Pin IM0-IM3

The MCU interface mode select					
IM3	IM2	IM1	IM0	MCU interface mode	Data Pin
0	0	0	0	80-8bit parallel I/F	DB[7:0]
0	0	0	1	80-16bit parallel I/F	DB[15:0]
0	0	1	0	80-24bit parallel I/F	DB[23:0]
0	0	1	1	RGB I/F, D[23:0]	16-bit SPI, SDI/SDO serial data, SCL rising trigger
1	0	1	1	RGB I/F, D[23:0]	16-bit SPI, SDI/SDO serial data, SCL falling trigger
0	1	0	0	RGB I/F, D[23:0]	I2C interface, I2C_SDA serial data
0	1	0	1	MIPI DSI I/F	DO_P/N, D1_P/N
0	1	1	0	MDDI I/F	DO_P/N, D1_P/N, SDI/SDO serial data, SCL rising trigger
1	1	1	0	MDDI I/F	DO_P/N, D1_P/N, SDI/SDO serial data, SCL falling trigger
0	1	1	1	MDDI I/F	DO_P/N, D1_P/N, I2C interface, I2C_SDA serial data

LANSEL	Data Lane of MIPI/MDDI	Data Pin
0	1 data lane	DO_P/N
1	2 data lanes	DO_P/N, D1_P/N,

DSWAP	PSWAP	DOP	DON	CKP	CKN	D1P	D1N
0	0	DOP	DON	CKP	CKN	D1P	D1N
0	1	DON	DOP	CKN	CKP	D1N	D1P
1	0	D1P	D1N	CKP	CKN	DOP	DON
1	1	D1N	D1P	CKN	CKP	DON	DOP

4. Electrical Characteristics

4-1 TFT LCD Module Operating Conditions

Item	Symbol	Condition	Min	Type	Max	Unit
Interface logic circuits	IOVCC	-	1.65	1.80	3.30	V
Analog Power supply	VCI	-	2.50	2.80	3.30	V
TFT Gate on voltage	VGH	-	10.0	-	16.0	V
TFT Gate off voltage	VGL	-	-16.0	-	-10.0	V

4-2 LED back light specification (pera chip)

Item	Symbol	Condition	Min	Type	Max	Unit
Forward voltage	Vt	If=20mA	14.0	15.5	17.0	V
Forward current	Ipn	/1-chip	-	40	-	mA
Luminance(With LCD)	Lv	If=20mA	-	500	-	cd/m ²
Luminous color	White					

4-3 CTP Operating Conditions

Item	Symbol	Condition	Min	Type	Max	Unit
Power Supply Voltages	VDD	-	2.50	2.80	3.60	V
I/O Digital Voltage	IOVDD	-	-	2.80	-	V
Operating Temperature	Topr	-	-	-	-	°C
Storage Temperature	Tstg	-	-5	-	-	°C

4. OPTICAL SPECIFICATION

4.1 Overview

The test of Optical specifications shall be measured in a dark room (ambient luminance 1lux and temperature = 25 ± 2°C) with the equipment of Luminance meter system (Goniometer system and TOPCON BM-5) and test unit shall be located at an approximate distance 50cm from the LCD surface at a viewing angle of θ and Φ equal to 0°. The center of the measuring spot on the Display surface shall stay fixed. The backlight should be operating for 30 minutes prior to measurement.

4.2 Optical Specifications

Parameter		Symbol	Condition	Min.	Typ.	Max.	Unit	Remark
Viewing Angle Range	Horizontal	Θ L	CR>10	-	80	-	Deg.	Note 1
		Θ R		-	80	-	Deg.	
	Vertical	Θ U		-	80	-	Deg.	
		Θ D		-	80	-	Deg.	
Contrast ratio		CR	$\Theta = 0^\circ$	1000	1500	-		Note2
Color Gamut		CG		65	70	-	%	
White Chromaticity		Wx		-	0.299	-		
		Wy		-	0.324	-		
Reproduction of color	Red	Rx	$\Theta = 0^\circ$	-	0.645	-		Note4 (Based on C Light)
		Ry		-	0.319	-		
	Green	Gx		-	0.271	-		
		Gy		-	0.594	-		
	Blue	Bx		-	0.138	-		
		By		-	0.098	-		
Response Time (Rising + Falling)		Tr+Tf	$\Theta = 0^\circ$ Ta= 25°C	-	35	40	ms	Note5
Transmittance		Tr		-	4.35		%	Note3

Note:

1.Viewing angle is the angle at which the contrast ratio is greater than 10. The viewing angles are determined for the horizontal or 3, 9 o' clock direction and the vertical or 6, 12 o' clock direction with respect to the optical axis which is normal to the LCD surface (see FIGURE 1).

2.Contrast measurements shall be made at viewing angle of $\Theta = 0$ and at the center of the LCD surface. Luminance shall be measured with all pixels in the view field set first to white, then to the dark (black)

state . (see FIGUR 1) Luminance Contrast Ratio (CR) is defined mathematically.

$$CR = \frac{\text{Luminance when displaying a white raster}}{\text{Luminance when displaying a black raster}}$$

3. Transmittance is the Value without APF and without CG.

4. The color chromaticity coordinates specified in the above table shall be calculated from the spectral data measured with all pixels first in red, green, blue and white. Measurements shall be made at the center of the panel.

5. The electro-optical response time measurements shall be made as FIGURE 2 by switching the “data” input signal ON and OFF. The times needed for the luminance to change from 10% to 90% is T_r , and 90% to 10% is T_f .

Figure1 Measurement Set Up

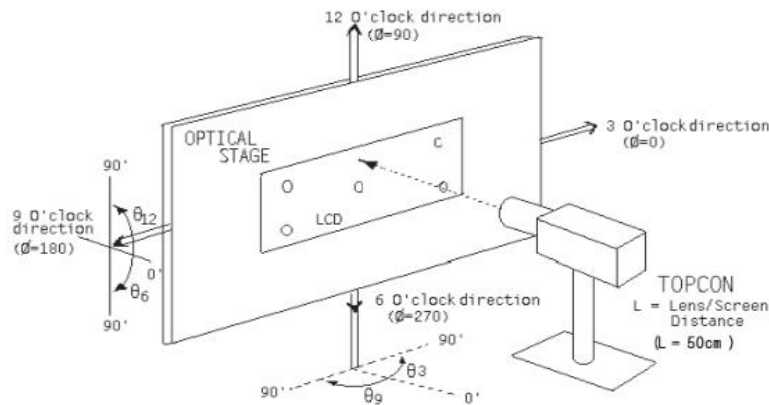
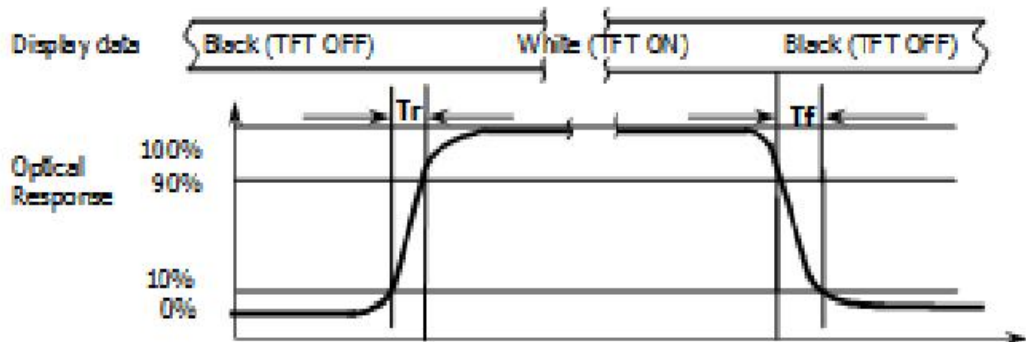
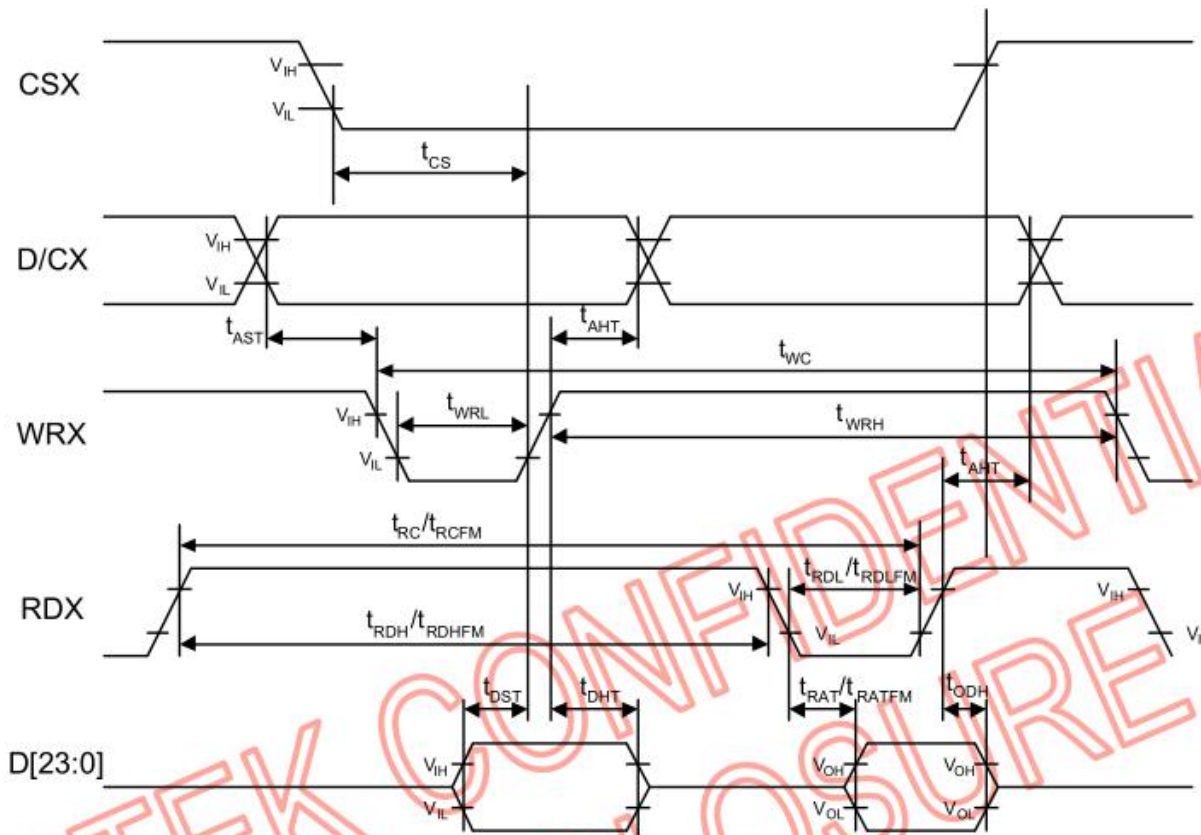

Figure2 Response Time Testing



6. Timing Characteristics of Input Signals

6-1 LCM 8080 Series MCU Parallel Interface Characteristics



(VSS=VSSI=DVSS=0V, VDDI=1.65V to 3.3V, VDD=2.3V to 4.8V, Ta = -30 to 70 °C)

Signal	Symbol	Parameter	MIN	MAX	Unit	Description
WRX	t _{WC}	Write cycle	33	-	ns	
	t _{WRH}	Control pulse "H" duration	15	-	ns	
	t _{WRL}	Control pulse "L" duration	15	-	ns	
RDX(ID)	t _{RC}	Read cycle (ID)	160	-	ns	When read ID data
	t _{RDH}	Control pulse "H" duration (ID)	90	-	ns	
	t _{RDL}	Control pulse "L" duration (ID)	45	-	ns	
RDX(FM)	t _{RCFM}	Read cycle (FM)	400	-	ns	When read from frame memory
	t _{RDHFM}	Control pulse "H" duration (FM)	250	-	ns	
	t _{RDLFM}	Control pulse "L" duration (FM)	150	-	ns	
D/CX	t _{AST}	Address setup time (Write)	0	-	ns	
	t _{AST}	Address setup time (Read)	10	-	ns	
	t _{AHT}	Address hole time	2	-	ns	
D[17:0]	t _{DST}	Data setup time	15	-	ns	
	t _{DHT}	Data hold time	10	-	ns	
	t _{RAT}	Read access time (ID)	-	40	ns	
	t _{RATFM}	Read access time (FM)	-	150	ns	
	t _{ODH}	Output disable time	5	-	ns	

Note 1) VDDI=1.65 to 3.3V, VDD=2.3 to 4.8V, VSS=VSSI=DVSS=0V, Ta=-30 to 70 °C (to +85 °C no damage)

VDD means VDDA, VDDR, Vddb and VSS means VSSA, VSSR, VSSB

Note 2) The input signal rise time and fall time (tr, tf) is specified at 15 ns or less.

Logic high and low levels are specified as 20% and 80% of VDDI for Input signals.

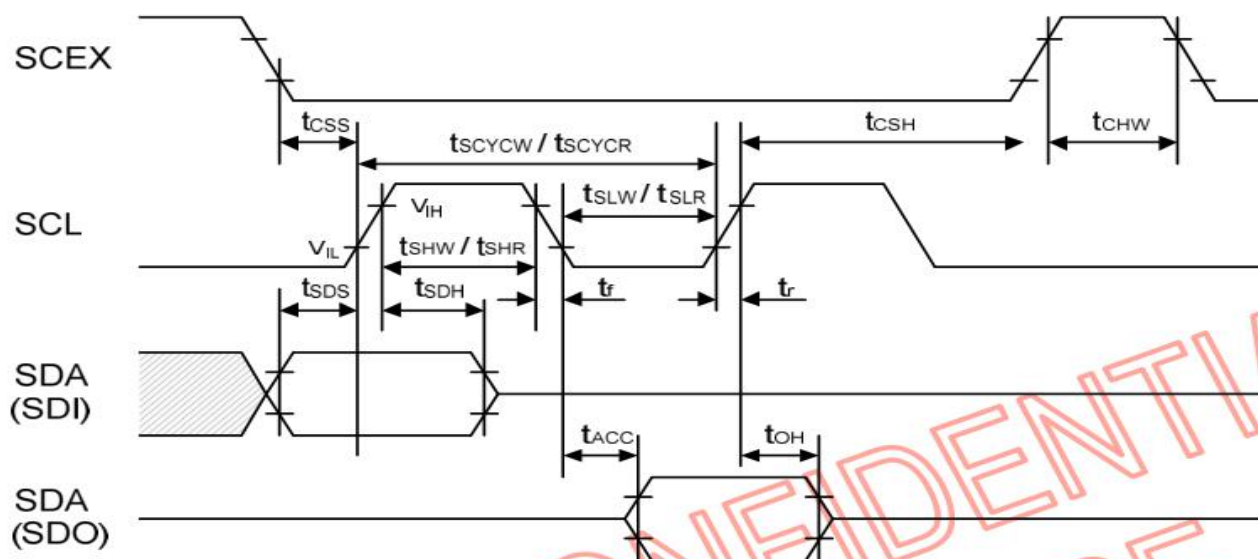
6-2 LCM Serial Interface Characteristics (3-line serial)

(VSS=VSSI=DVSS=0V, VDDI=1.65V to 3.3V, VDD=2.3V to 4.8V, Ta = -30 to 70 °C)

Signal	Symbol	Parameter	MIN	MAX	Unit	Description
SCL	tscycw	Serial clock cycle (Write)	100	-	ns	
	tshw	SCL "H" pulse width (Write)	40	-	ns	
	tslw	SCL "L" pulse width (Write)	40	-	ns	
	tscyrcr	Serial clock cycle (Read GRAM)	300	-	ns	
	tshr	SCL "H" pulse width (Read GRAM)	140	-	ns	
	tslr	SCL "L" pulse width (Read GRAM)	140	-	ns	
	tscyrcr	Serial clock cycle (Read ID)	300	-	ns	
	tshr	SCL "H" pulse width (Read ID)	140	-	ns	
	tslr	SCL "L" pulse width (Read ID)	140	-	ns	
SDI (SDO)	tSDS	Data setup time	20	-	ns	
	tSDH	Data hold time	20	-	ns	
	tACC	Access time	-	120	ns	
	toH	Output disable time	5	-	ns	
CSX	tCHW	Chip select "H" pulse width	45	-	ns	
	tCSS	Chip select setup time	20	-	ns	
	tCSH	Chip select hold time	50	-	ns	

Note 1) VDDI=1.65 to 3.3V, VDD=2.3 to 4.8V, VSS=VSSI=DVSS=0V, Ta=-30 to 70 °C (to +85 °C no damage)

VDD means VDDA, VDDR, VDDB and VSS means VSSA, VSSR, VSSB

Note 2) The input signal rise time and fall time (tr, tf) is specified at 15 ns or less.

6-3 LCM I2C Bus Timing Characteristics

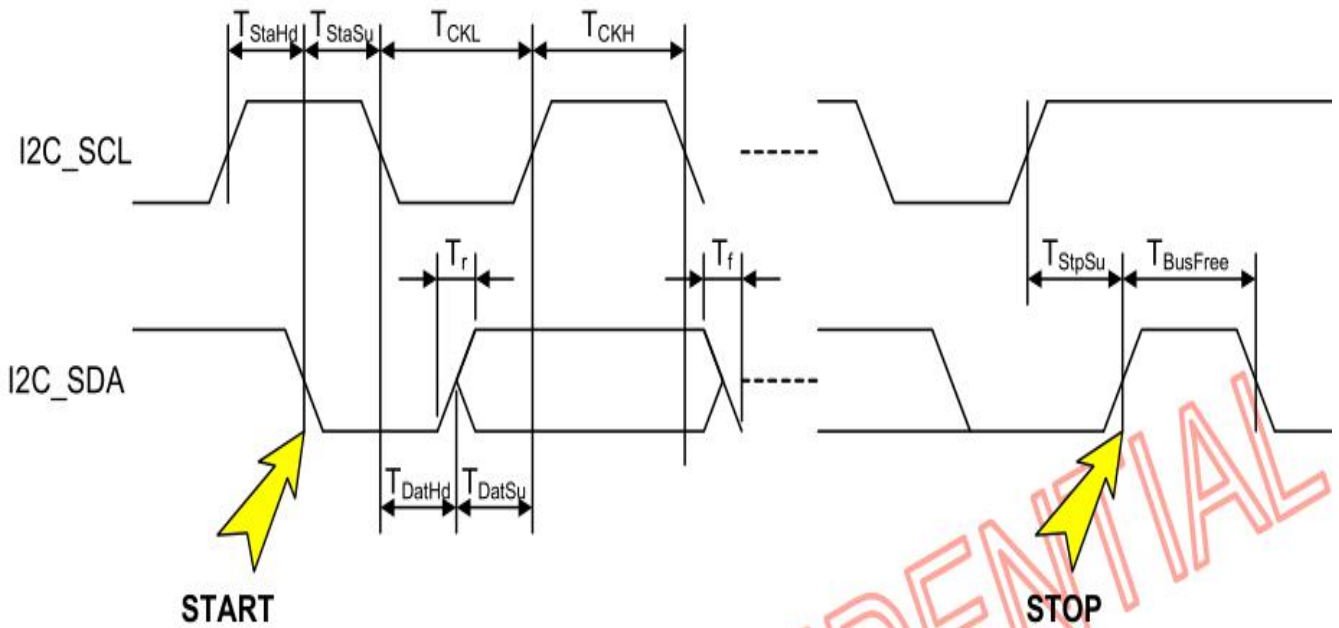

(VSS=VSSI=DVSS=0V, VDDI=1.65V to 3.3V, VDD=2.3V to 4.8V, Ta = -30 to 70 °C)

Signal	Symbol	Parameter	MIN	MAX	Unit	Description
I2C_SCL	$T_{CKL}+T_{CKH}$	Working frequency	-	400	KHz	
	T_{CKL}	I2C clock low	1300	-	ns	
	T_{CKH}	I2C clock high	600	-	ns	
I2C_SDA	T_r	I2C data rising time	-	300	ns	
	T_f	I2C data falling time	-	300	ns	
	T_{DatHd}	I2C data hold time	0	900	ns	
	T_{DatSu}	I2C data setup time	100	-	ns	
	T_{StaHd}	I2C start condition hold time	600	-	ns	
	T_{StaSu}	I2C start condition setup time	600	-	ns	
	T_{StpSu}	I2C stop condition setup time	600	-	ns	
	$T_{BusFree}$	I2C bus free time	1300	-	ns	

Note 1) VDDI=1.65 to 3.3V, VDD=2.3 to 4.8V, VSS=VSSI=DVSS=0V, Ta=-30 to 70 °C (to +85 °C no damage)

VDD means VDDA, VDDR, VDDB and VSS means VSSA, VSSR, VSSB

6-4 LCM RGB Interface Characteristics

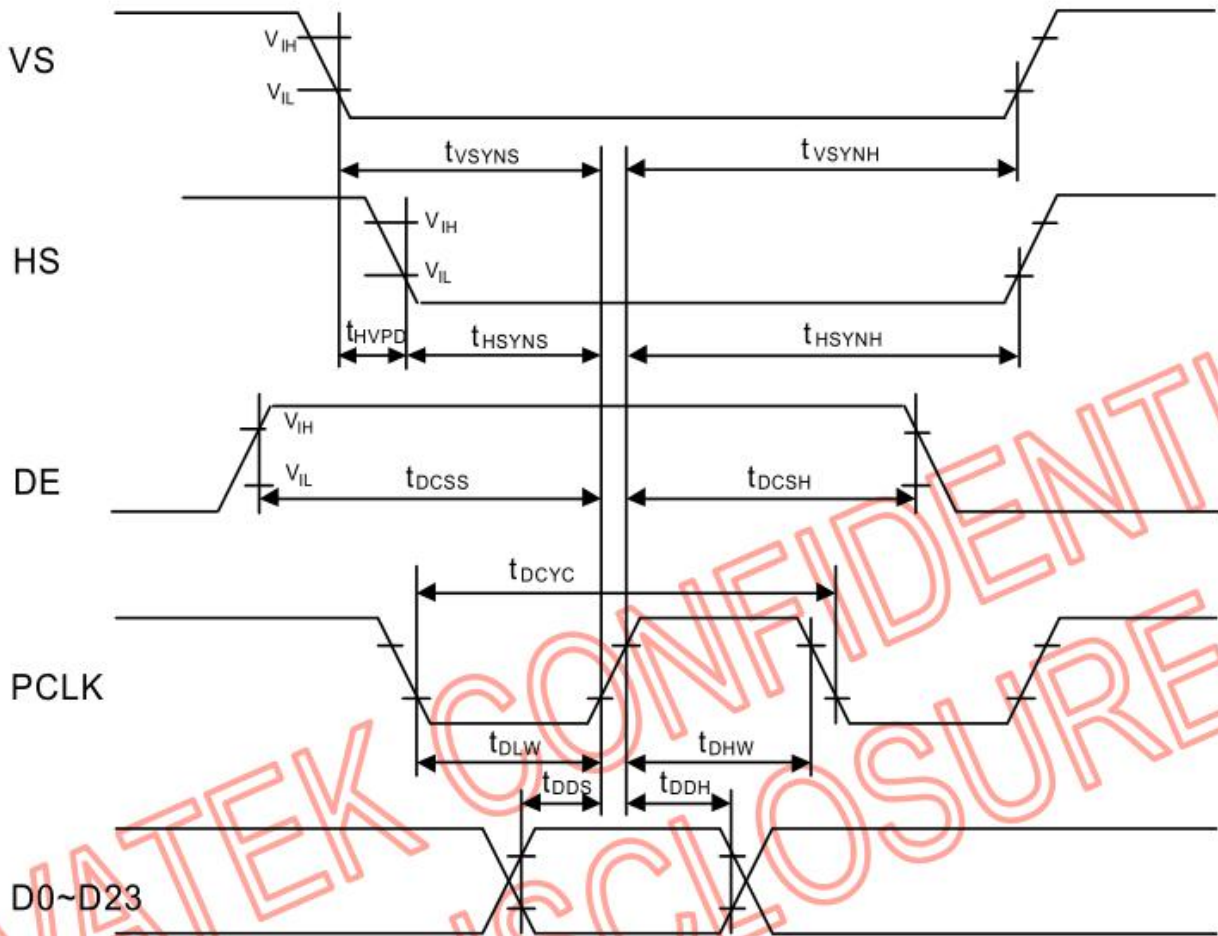

(VSS=VSSI=DVSS=0V, VDDI=1.65V to 3.3V, VDD=2.3V to 4.8V, Ta = -30 to 70 °C)

Signal	Symbol	Parameter	MIN	TYP	MAX	Unit	Description
VS	t_{VSYNS}	VSYNC setup time	10	-	-	ns	
	t_{VSYNH}	VSYNC hold time	10	-	-	ns	
HS	t_{HSYNS}	HSYNC setup time	10	-	-	ns	
	t_{SCYCR}	HSYNC hold time	10	-	-	ns	
	t_{HVPE}	HSYNC to VSYNC falling edge	400	-	-	ns	
PCLK	t_{DCYC}	PCLK cycle time	33	-	125	ns	
	t_{DLW}	PCLK "L" pulse width	11	-	-	ns	
	t_{DHW}	PCLK "H" pulse width	11	-	-	ns	
	f_{DFREQ}	PCLK frequency	8	-	30	MHz	
DE	t_{DCSS}	DE setup time	10	-	-	ns	
	t_{DCSH}	DE hold Time	10	-	-	ns	
D0~D23	t_{DDS}	RGB Data setup time	10	-	-	ns	
	t_{DDH}	RGB Data hold time	10	-	-	ns	

Note 1) VDDI=1.65 to 3.3V, VDD=2.3 to 4.8V, VSS=VSSI=DVSS=0V, Ta=-30 to 70 °C (to +85 °C no damage)

VDD means VDDA, VDDR, Vddb and VSS means VSSA, VSSR, VSSB

Note 2) The input signal rise time and fall time (tr, tf) is specified at 15 ns or less.

6-5 LCM MIPI Interface Characteristics

6-5-1 HIGH SPEED MODE

(VSS=VSSI=DVSS=0V, VDDI=1.65V to 3.3V, VDD=2.3V to 4.8V, Ta = -30 to 70 °C)

Signal	Symbol	Parameter	MIN	TYP	MAX	Unit	Description
DSI-CLK+/-	2xUI _{INST}	Double UI instantaneous	4	-	25	ns	
DSI-CLK+/-	UI _{INSTA} UI _{INSTB}	UI instantaneous halves	2	-	12.5	ns	UI = UI _{INSTA} = UI _{INSTB}
DSI-Dn+/-	t _{DS}	Data to clock setup time	0.15xUI	-	-	ps	
DSI-Dn+/-	t _{DH}	Data to clock hold time	0.15xUI	-	-	ps	
DSI-CLK+/-	t _{DRTCLK}	Differential rise time for clock	150	-	0.3xUI	ps	
DSI-Dn+/-	t _{DRTDATA}	Differential rise time for data	150	-	0.3xUI	ps	
DSI-CLK+/-	t _{DFTCLK}	Differential fall time for clock	150	-	0.3xUI	ps	
DSI-Dn+/-	t _{DFTDATA}	Differential fall time for data	150	-	0.3xUI	ps	

Note) Dn = D0 and D1.

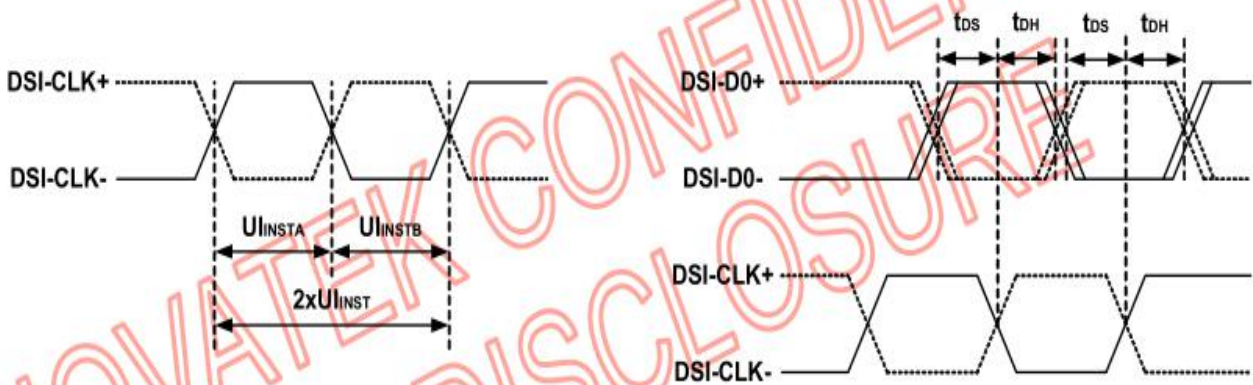

Fig. 7.6.4 DSI clock channel timing

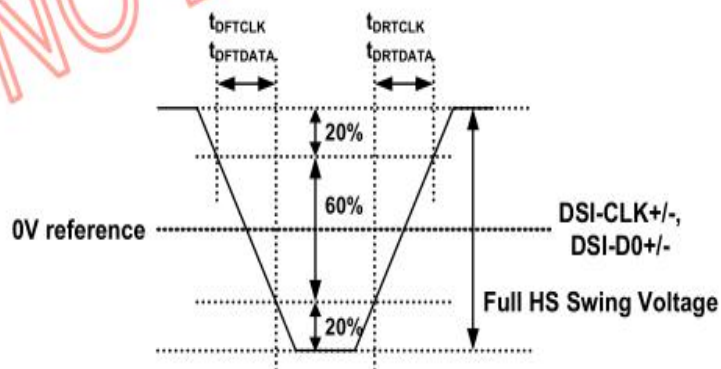

Fig. 7.6.5 Rising and fall time on clock and data channel

6-5-2 LOW POWER MODE

(VSS=VSSI=DVSS=0V, VDDI=1.65V to 3.3V, VDD=2.3V to 4.8V, Ta = -30 to 70 °C)

Signal	Symbol	Parameter	MIN	TYP	MAX	Unit	Description
DSI-D0+/-	T _{LPXM}	Length of LP-00, LP-01, LP-10 or LP-11 periods MPU → Display Module	50	-	75	ns	Input
DSI-D0+/-	T _{LPXD}	Length of LP-00, LP-01, LP-10 or LP-11 periods Display Module → MPU	50	-	75	ns	Output
DSI-D0+/-	T _{TA-SURED}	Time-out before the MPU start driving	T _{LPXD}	-	2xT _{LPXD}	ns	Output
DSI-D0+/-	T _{TA-GETD}	Time to drive LP-00 by display module	5xT _{LPXD}	-	-	ns	Input
DSI-D0+/-	T _{TA-GOD}	Time to drive LP-00 after turnaround request - MPU	4xT _{LPXD}	-	-	ns	Output

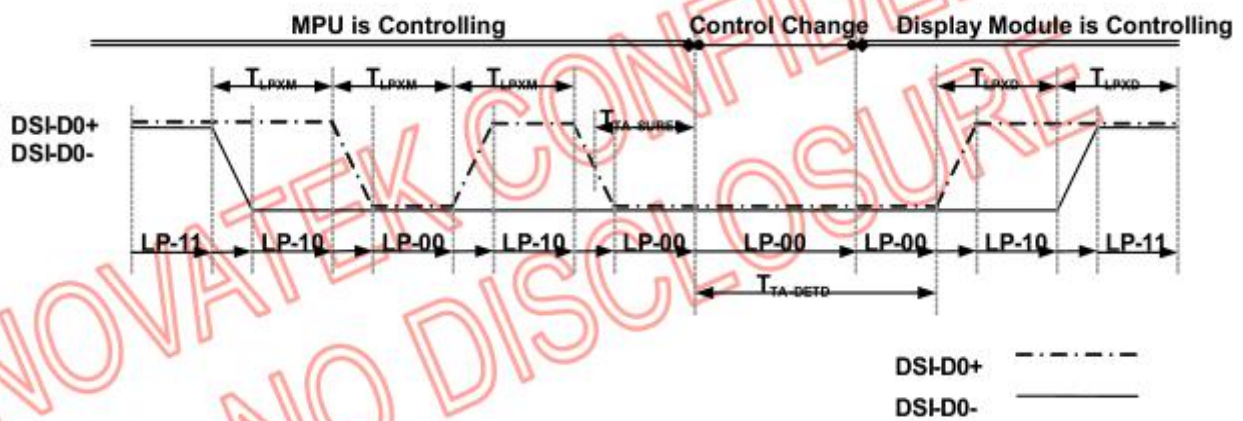

Fig. 7.6.6 Bus Turnaround (BAT) from MPU to display module Timing

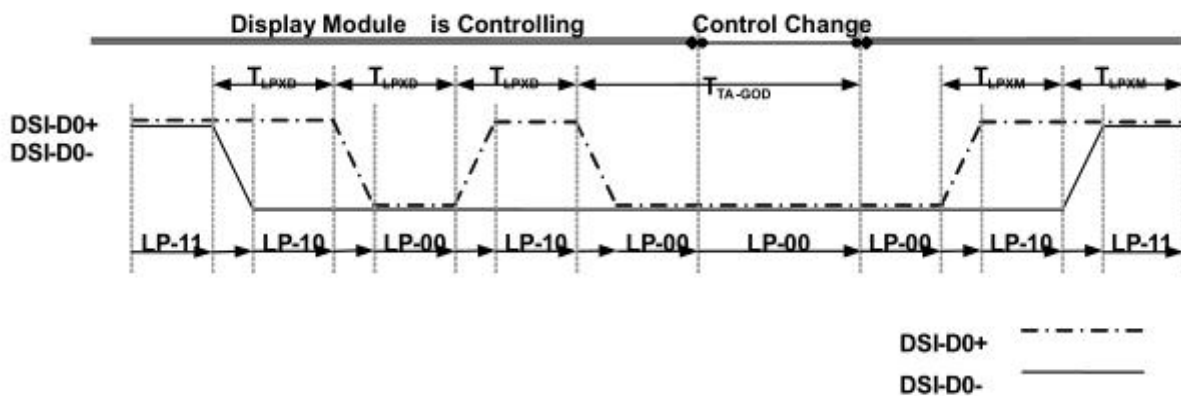

Fig. 7.6.7 Bus Turnaround (BAT) from display module to MPU Timing

6-6 LCM MIDI Interface Characteristics

(VSS=VSSI=DVSS=0V, VDDI=1.65V to 3.3V, VDD=2.3V to 4.8V, Ta = -30 to 70 °C)

Signal	Symbol	Parameter	MIN	TYP	MAX	Unit	Description
MDDI_STB_P/M MDDI_DATA_P/M	1/Tbit	Data transfer rate	-	384	450	Mbps	
MDDI_STB_P/M MDDI_DATA_P/M	Tskew-pair	Differential transfer input skew	-	-	0.05	ns	
MDDI_STB_P/M MDDI_DATA_P/M	Tskew-data	Data/Strobe input skew	-	-	0.3	ns	

Note) MDDI_DATA_P/M = MDDI_DATA0_P/M and MDDI_DATA1_P/M.

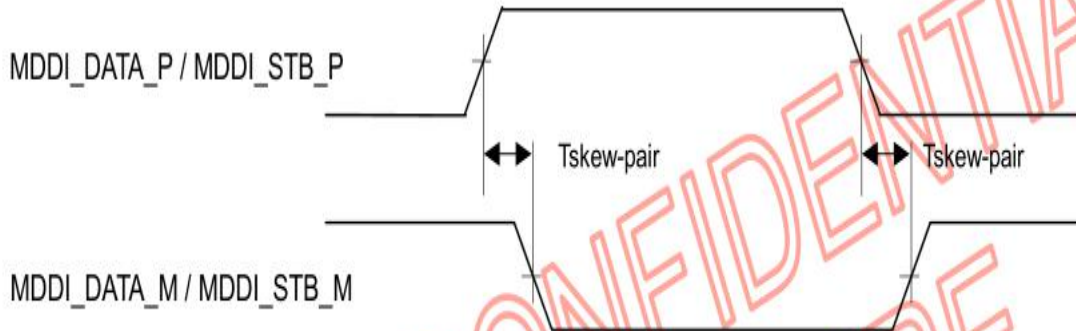

Fig. 7.6.10 Skew between MDDI positive and negative signal pair

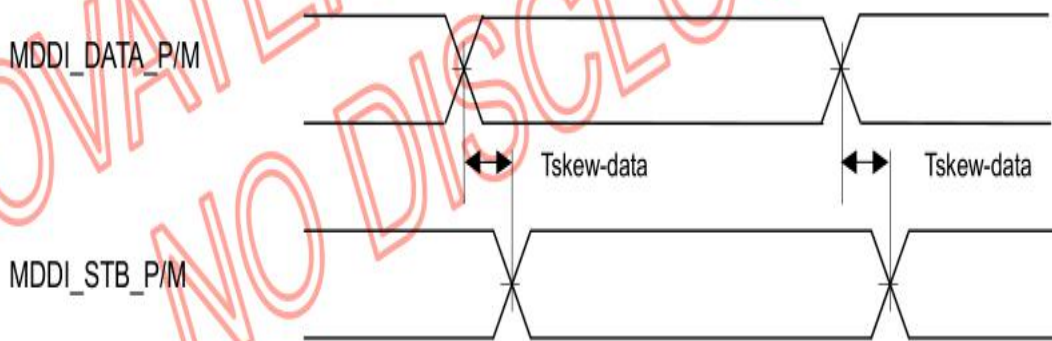

Fig. 7.6.11 Skew between MDDI_DATA_P/M and MDDI_STB_P/M

7. RELIABILITY TEST

7-1 Temperature and Humidity

Test Item	Test Condition	Check Time
High Temp Storage	Ta= 80°C	240 hrs
Low Temp Storage	Ta= -30°C	240 hrs
High Temp Operation	Ta= 70°C	240 hrs
Low Temp Operation	Ta= -20°C	240 hrs
High Temp & High Humidity Operation	Ta=60°C H=90%RH	240 hrs

Note: (1) Ta : Ambient temperature

(2) All judgments of display are performed after temp of panel returns to room temperature

(3) Display function should be no change under normal operating condition.

(4) Under no condensation of dew

(5)*INX only guarantee the above 5 test items. INX wouldn't guarantee the others not shown as the above ones..

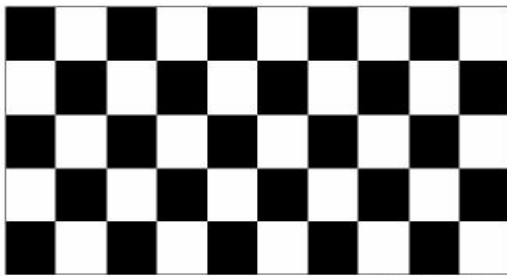

(a) Test Pattern (chess board Pattern)



(b) Gray Pattern

7-2 Shock and Vibration

ITEMS	CONDITIONS
Packing Shock (Non-Operation)	<ul style="list-style-type: none"> ● Shock level:980m/s² ● Waveform:1/2 Sine wave,6msec ● ±X, ±Y ±Z,each axis 1 times
Packing Vibration (Non-Operation)	<ul style="list-style-type: none"> ● Frequency range:8-33.3HZ ● Stoke:1.0mm ● Sweep: 10Hz-50Hz ● x,y,z 2 hours for each direction

7-3 Electrostatic Discharge

TEST ITEM	CONDITIONS
ESD (Non-operation)	150pF,330Ω , Contact±4KV,Air :±8KV.Note 1
	200pF,0Ω , ±200V Contact test.Note 2

Note:Measure Point:

1.LCD glass and metal bezel

2.IF connector pins

8.HANDDLING & CAUTIONS

8-1 Caution For Operation

◆Since the LCM is made of glass, do not apply strong mechanical impact or static load onto it. Handling with care since shock, vibration, and careless handling may seriously affect the product. If it falls from a high place or receives a strong shock, the glass maybe broken.

◆It is indispensable to drive the LCM within the specified voltage limit since the higher voltage than the limit causes LCM's life shorter. An electro-chemical reaction due to DC causes undesirable deterioration of the LCM so that the use of DC drive should avoid.

◆Do not connect or disconnect the LCM to or from the system when power is on.

◆Never use the LCM under abnormal conditions of high temperature and high humidity.

◆When expose to drastic fluctuation of temperature(hot to cold or cold to hot), the LCM may be affected; specifically, drastic temperature fluctuation from cold to hot, produces dew on the LCM's surface which may affect the operation of the polarizer on the LCM.

◆Response time will be extremely delay at lower temperature than the operating temperature range and on the other hand LCM may turn black at temperature above its operational range. However those phenomenon do not mean malfunction or out of order with the LCM. The LCM will revert to normal operation once the temperature returns to the recommended temperature range for normal operation.

◆Do not display the fixed pattern for a long time when using a normally black panel, as it may cause image sticking due to the LCM structure. If the screen is displayed in fixed mode,

◆Do not disassemble and/or re-assemble LCM module use a screen saver. It is recommended to display the fixed mode in less than 2 minutes or less.

7-2 Caution Against Static Charge

◆The LCM use C-MOS LSI drivers, so customers are recommended that any unused input terminal would be connected to Vdd or Vss, do not input any signals before power is turn on, and ground you body, work/assembly area, assembly equipments to protect against static electricity.

◆Remove the protective film slowly, keeping the removing direction approximate 30-degree not vertical from panel surface, if possible, under ESD control device like ion blower, and the humidity of working room should be kept over 50%RH to reduce the risk of static charge.

◆Avoid the use work clothing made of synthetic fibers. We recommend cotton clothing or other conductivity-treated fibers.

◆In handling the LCM, wear non-charged material gloves. And the conducting wrist to the earth and the conducting shoes to the earth are necessary

9. LCD display initialization code

This initialization code is verified by the MCU interface

```
Void Panel_initial_code(void)
```

```
{  
  
    RST=1;  
    Delay(200);  
  
    RST=0;  
    Delay(800);  
  
    RST=1;  
    Delay(800);  
  
    WriteComm(0xF000);WriteData(0x55);  
    WriteComm(0xF001);WriteData(0xAA);  
    WriteComm(0xF002);WriteData(0x52);  
    WriteComm(0xF003);WriteData(0x08);  
    WriteComm(0xF004);WriteData(0x01);  
  
    //AVDD ratio  
    WriteComm(0xB600);WriteData(0x34);  
    WriteComm(0xB601);WriteData(0x34);  
    WriteComm(0xB602);WriteData(0x34);  
  
    //AVDD Set AVDD 5.2V  
    WriteComm(0xB000);WriteData(0x0C);  
    WriteComm(0xB001);WriteData(0x0C);  
    WriteComm(0xB002);WriteData(0x0C);  
  
    //AVEE ratio  
    WriteComm(0xB700);WriteData(0x24);  
    WriteComm(0xB701);WriteData(0x24);  
    WriteComm(0xB702);WriteData(0x24);  
  
    //AVEE -5.2V  
    WriteComm(0xB100);WriteData(0x0C);  
    WriteComm(0xB101);WriteData(0x0C);  
    WriteComm(0xB102);WriteData(0x0C);
```

//VCL ratio

WriteComm(0xB800);WriteData(0x34);
WriteComm(0xB801);WriteData(0x34);
WriteComm(0xB802);WriteData(0x34);

//VCL -2.5V

WriteComm(0xB200);WriteData(0x00);
WriteComm(0xB201);WriteData(0x00);
WriteComm(0xB202);WriteData(0x00);

//VGH ratio

WriteComm(0xB900);WriteData(0x34);
WriteComm(0xB901);WriteData(0x34);
WriteComm(0xB902);WriteData(0x34);

//VGH 15V (Free pump)

WriteComm(0xBF00);WriteData(0x01);
WriteComm(0xB300);WriteData(0x08);
WriteComm(0xB301);WriteData(0x08);
WriteComm(0xB302);WriteData(0x08);

//VGLX ratio

WriteComm(0xBA00);WriteData(0x14);
WriteComm(0xBA01);WriteData(0x14);
WriteComm(0xBA02);WriteData(0x14);

//VGL_REG -10V

WriteComm(0xB500);WriteData(0x08);
WriteComm(0xB501);WriteData(0x08);
WriteComm(0xB502);WriteData(0x08);

WriteComm(0xC200);WriteData(0x03);

//VGMP/VGSP 4.5V/0V

WriteComm(0xBC00);WriteData(0x00);
WriteComm(0xBC01);WriteData(0x80);
WriteComm(0xBC02);WriteData(0x00);

//VGMN/VGSN -4.5V/0V

WriteComm(0xBD00);WriteData(0x00);
WriteComm(0xBD01);WriteData(0x80);
WriteComm(0xBD02);WriteData(0x00);

//VCOM

WriteComm(0xBE00);WriteData(0x00);
WriteComm(0xBE01);WriteData(0x2F);

//Gamma Setting

WriteComm(0xD100);WriteData(0x00);
WriteComm(0xD101);WriteData(0x37);
WriteComm(0xD102);WriteData(0x00);
WriteComm(0xD103);WriteData(0x53);
WriteComm(0xD104);WriteData(0x00);
WriteComm(0xD105);WriteData(0x79);
WriteComm(0xD106);WriteData(0x00);
WriteComm(0xD107);WriteData(0x97);
WriteComm(0xD108);WriteData(0x00);
WriteComm(0xD109);WriteData(0xB1);
WriteComm(0xD10A);WriteData(0x00);
WriteComm(0xD10B);WriteData(0xD5);
WriteComm(0xD10C);WriteData(0x00);
WriteComm(0xD10D);WriteData(0xF4);
WriteComm(0xD10E);WriteData(0x01);
WriteComm(0xD10F);WriteData(0x23);
WriteComm(0xD110);WriteData(0x01);
WriteComm(0xD111);WriteData(0x49);
WriteComm(0xD112);WriteData(0x01);
WriteComm(0xD113);WriteData(0x87);
WriteComm(0xD114);WriteData(0x01);
WriteComm(0xD115);WriteData(0xB6);
WriteComm(0xD116);WriteData(0x02);
WriteComm(0xD117);WriteData(0x00);
WriteComm(0xD118);WriteData(0x02);
WriteComm(0xD119);WriteData(0x3B);
WriteComm(0xD11A);WriteData(0x02);
WriteComm(0xD11B);WriteData(0x3D);
WriteComm(0xD11C);WriteData(0x02);
WriteComm(0xD11D);WriteData(0x75);
WriteComm(0xD11E);WriteData(0x02);

WriteComm(0xD11F);WriteData(0xB1);
WriteComm(0xD120);WriteData(0x02);
WriteComm(0xD121);WriteData(0xD5);
WriteComm(0xD122);WriteData(0x03);
WriteComm(0xD123);WriteData(0x09);
WriteComm(0xD124);WriteData(0x03);
WriteComm(0xD125);WriteData(0x28);
WriteComm(0xD126);WriteData(0x03);
WriteComm(0xD127);WriteData(0x52);
WriteComm(0xD128);WriteData(0x03);
WriteComm(0xD129);WriteData(0x6B);
WriteComm(0xD12A);WriteData(0x03);
WriteComm(0xD12B);WriteData(0x8D);
WriteComm(0xD12C);WriteData(0x03);
WriteComm(0xD12D);WriteData(0xA2);
WriteComm(0xD12E);WriteData(0x03);
WriteComm(0xD12F);WriteData(0xBB);
WriteComm(0xD130);WriteData(0x03);
WriteComm(0xD131);WriteData(0xC1);
WriteComm(0xD132);WriteData(0x03);
WriteComm(0xD133);WriteData(0xC1);

WriteComm(0xD200);WriteData(0x00);
WriteComm(0xD201);WriteData(0x37);
WriteComm(0xD202);WriteData(0x00);
WriteComm(0xD203);WriteData(0x53);
WriteComm(0xD204);WriteData(0x00);
WriteComm(0xD205);WriteData(0x79);
WriteComm(0xD206);WriteData(0x00);
WriteComm(0xD207);WriteData(0x97);
WriteComm(0xD208);WriteData(0x00);
WriteComm(0xD209);WriteData(0xB1);
WriteComm(0xD20A);WriteData(0x00);
WriteComm(0xD20B);WriteData(0xD5);
WriteComm(0xD20C);WriteData(0x00);
WriteComm(0xD20D);WriteData(0xF4);
WriteComm(0xD20E);WriteData(0x01);
WriteComm(0xD20F);WriteData(0x23);
WriteComm(0xD210);WriteData(0x01);
WriteComm(0xD211);WriteData(0x49);

WriteComm(0xD212);WriteData(0x01);
WriteComm(0xD213);WriteData(0x87);
WriteComm(0xD214);WriteData(0x01);
WriteComm(0xD215);WriteData(0xB6);
WriteComm(0xD216);WriteData(0x02);
WriteComm(0xD217);WriteData(0x00);
WriteComm(0xD218);WriteData(0x02);
WriteComm(0xD219);WriteData(0x3B);
WriteComm(0xD21A);WriteData(0x02);
WriteComm(0xD21B);WriteData(0x3D);
WriteComm(0xD21C);WriteData(0x02);
WriteComm(0xD21D);WriteData(0x75);
WriteComm(0xD21E);WriteData(0x02);
WriteComm(0xD21F);WriteData(0xB1);
WriteComm(0xD220);WriteData(0x02);
WriteComm(0xD221);WriteData(0xD5);
WriteComm(0xD222);WriteData(0x03);
WriteComm(0xD223);WriteData(0x09);
WriteComm(0xD224);WriteData(0x03);
WriteComm(0xD225);WriteData(0x28);
WriteComm(0xD226);WriteData(0x03);
WriteComm(0xD227);WriteData(0x52);
WriteComm(0xD228);WriteData(0x03);
WriteComm(0xD229);WriteData(0x6B);
WriteComm(0xD22A);WriteData(0x03);
WriteComm(0xD22B);WriteData(0x8D);
WriteComm(0xD22C);WriteData(0x03);
WriteComm(0xD22D);WriteData(0xA2);
WriteComm(0xD22E);WriteData(0x03);
WriteComm(0xD22F);WriteData(0xBB);
WriteComm(0xD230);WriteData(0x03);
WriteComm(0xD231);WriteData(0xC1);
WriteComm(0xD232);WriteData(0x03);
WriteComm(0xD233);WriteData(0xC1);

WriteComm(0xD300);WriteData(0x00);
WriteComm(0xD301);WriteData(0x37);
WriteComm(0xD302);WriteData(0x00);
WriteComm(0xD303);WriteData(0x53);
WriteComm(0xD304);WriteData(0x00);

WriteComm(0xD305);WriteData(0x79);
WriteComm(0xD306);WriteData(0x00);
WriteComm(0xD307);WriteData(0x97);
WriteComm(0xD308);WriteData(0x00);
WriteComm(0xD309);WriteData(0xB1);
WriteComm(0xD30A);WriteData(0x00);
WriteComm(0xD30B);WriteData(0xD5);
WriteComm(0xD30C);WriteData(0x00);
WriteComm(0xD30D);WriteData(0xF4);
WriteComm(0xD30E);WriteData(0x01);
WriteComm(0xD30F);WriteData(0x23);
WriteComm(0xD310);WriteData(0x01);
WriteComm(0xD311);WriteData(0x49);
WriteComm(0xD312);WriteData(0x01);
WriteComm(0xD313);WriteData(0x87);
WriteComm(0xD314);WriteData(0x01);
WriteComm(0xD315);WriteData(0xB6);
WriteComm(0xD316);WriteData(0x02);
WriteComm(0xD317);WriteData(0x00);
WriteComm(0xD318);WriteData(0x02);
WriteComm(0xD319);WriteData(0x3B);
WriteComm(0xD31A);WriteData(0x02);
WriteComm(0xD31B);WriteData(0x3D);
WriteComm(0xD31C);WriteData(0x02);
WriteComm(0xD31D);WriteData(0x75);
WriteComm(0xD31E);WriteData(0x02);
WriteComm(0xD31F);WriteData(0xB1);
WriteComm(0xD320);WriteData(0x02);
WriteComm(0xD321);WriteData(0xD5);
WriteComm(0xD322);WriteData(0x03);
WriteComm(0xD323);WriteData(0x09);
WriteComm(0xD324);WriteData(0x03);
WriteComm(0xD325);WriteData(0x28);
WriteComm(0xD326);WriteData(0x03);
WriteComm(0xD327);WriteData(0x52);
WriteComm(0xD328);WriteData(0x03);
WriteComm(0xD329);WriteData(0x6B);
WriteComm(0xD32A);WriteData(0x03);
WriteComm(0xD32B);WriteData(0x8D);
WriteComm(0xD32C);WriteData(0x03);

WriteComm(0xD32D);WriteData(0xA2);
WriteComm(0xD32E);WriteData(0x03);
WriteComm(0xD32F);WriteData(0xBB);
WriteComm(0xD330);WriteData(0x03);
WriteComm(0xD331);WriteData(0xC1);
WriteComm(0xD332);WriteData(0x03);
WriteComm(0xD333);WriteData(0xC1);

WriteComm(0xD400);WriteData(0x00);
WriteComm(0xD401);WriteData(0x37);
WriteComm(0xD402);WriteData(0x00);
WriteComm(0xD403);WriteData(0x53);
WriteComm(0xD404);WriteData(0x00);
WriteComm(0xD405);WriteData(0x79);
WriteComm(0xD406);WriteData(0x00);
WriteComm(0xD407);WriteData(0x97);
WriteComm(0xD408);WriteData(0x00);
WriteComm(0xD409);WriteData(0xB1);
WriteComm(0xD40A);WriteData(0x00);
WriteComm(0xD40B);WriteData(0xD5);
WriteComm(0xD40C);WriteData(0x00);
WriteComm(0xD40D);WriteData(0xF4);
WriteComm(0xD40E);WriteData(0x01);
WriteComm(0xD40F);WriteData(0x23);
WriteComm(0xD410);WriteData(0x01);
WriteComm(0xD411);WriteData(0x49);
WriteComm(0xD412);WriteData(0x01);
WriteComm(0xD413);WriteData(0x87);
WriteComm(0xD414);WriteData(0x01);
WriteComm(0xD415);WriteData(0xB6);
WriteComm(0xD416);WriteData(0x02);
WriteComm(0xD417);WriteData(0x00);
WriteComm(0xD418);WriteData(0x02);
WriteComm(0xD419);WriteData(0x3B);
WriteComm(0xD41A);WriteData(0x02);
WriteComm(0xD41B);WriteData(0x3D);
WriteComm(0xD41C);WriteData(0x02);
WriteComm(0xD41D);WriteData(0x75);
WriteComm(0xD41E);WriteData(0x02);
WriteComm(0xD41F);WriteData(0xB1);

WriteComm(0xD420);WriteData(0x02);
WriteComm(0xD421);WriteData(0xD5);
WriteComm(0xD422);WriteData(0x03);
WriteComm(0xD423);WriteData(0x09);
WriteComm(0xD424);WriteData(0x03);
WriteComm(0xD425);WriteData(0x28);
WriteComm(0xD426);WriteData(0x03);
WriteComm(0xD427);WriteData(0x52);
WriteComm(0xD428);WriteData(0x03);
WriteComm(0xD429);WriteData(0x6B);
WriteComm(0xD42A);WriteData(0x03);
WriteComm(0xD42B);WriteData(0x8D);
WriteComm(0xD42C);WriteData(0x03);
WriteComm(0xD42D);WriteData(0xA2);
WriteComm(0xD42E);WriteData(0x03);
WriteComm(0xD42F);WriteData(0xBB);
WriteComm(0xD430);WriteData(0x03);
WriteComm(0xD431);WriteData(0xC1);
WriteComm(0xD432);WriteData(0x03);
WriteComm(0xD433);WriteData(0xC1);

WriteComm(0xD500);WriteData(0x00);
WriteComm(0xD501);WriteData(0x37);
WriteComm(0xD502);WriteData(0x00);
WriteComm(0xD503);WriteData(0x53);
WriteComm(0xD504);WriteData(0x00);
WriteComm(0xD505);WriteData(0x79);
WriteComm(0xD506);WriteData(0x00);
WriteComm(0xD507);WriteData(0x97);
WriteComm(0xD508);WriteData(0x00);
WriteComm(0xD509);WriteData(0xB1);
WriteComm(0xD50A);WriteData(0x00);
WriteComm(0xD50B);WriteData(0xD5);
WriteComm(0xD50C);WriteData(0x00);
WriteComm(0xD50D);WriteData(0xF4);
WriteComm(0xD50E);WriteData(0x01);
WriteComm(0xD50F);WriteData(0x23);
WriteComm(0xD510);WriteData(0x01);
WriteComm(0xD511);WriteData(0x49);
WriteComm(0xD512);WriteData(0x01);

WriteComm(0xD513);WriteData(0x87);
WriteComm(0xD514);WriteData(0x01);
WriteComm(0xD515);WriteData(0xB6);
WriteComm(0xD516);WriteData(0x02);
WriteComm(0xD517);WriteData(0x00);
WriteComm(0xD518);WriteData(0x02);
WriteComm(0xD519);WriteData(0x3B);
WriteComm(0xD51A);WriteData(0x02);
WriteComm(0xD51B);WriteData(0x3D);
WriteComm(0xD51C);WriteData(0x02);
WriteComm(0xD51D);WriteData(0x75);
WriteComm(0xD51E);WriteData(0x02);
WriteComm(0xD51F);WriteData(0xB1);
WriteComm(0xD520);WriteData(0x02);
WriteComm(0xD521);WriteData(0xD5);
WriteComm(0xD522);WriteData(0x03);
WriteComm(0xD523);WriteData(0x09);
WriteComm(0xD524);WriteData(0x03);
WriteComm(0xD525);WriteData(0x28);
WriteComm(0xD526);WriteData(0x03);
WriteComm(0xD527);WriteData(0x52);
WriteComm(0xD528);WriteData(0x03);
WriteComm(0xD529);WriteData(0x6B);
WriteComm(0xD52A);WriteData(0x03);
WriteComm(0xD52B);WriteData(0x8D);
WriteComm(0xD52C);WriteData(0x03);
WriteComm(0xD52D);WriteData(0xA2);
WriteComm(0xD52E);WriteData(0x03);
WriteComm(0xD52F);WriteData(0xBB);
WriteComm(0xD530);WriteData(0x03);
WriteComm(0xD531);WriteData(0xC1);
WriteComm(0xD532);WriteData(0x03);
WriteComm(0xD533);WriteData(0xC1);

WriteComm(0xD600);WriteData(0x00);
WriteComm(0xD601);WriteData(0x37);
WriteComm(0xD602);WriteData(0x00);
WriteComm(0xD603);WriteData(0x53);
WriteComm(0xD604);WriteData(0x00);
WriteComm(0xD605);WriteData(0x79);

WriteComm(0xD606);WriteData(0x00);
WriteComm(0xD607);WriteData(0x97);
WriteComm(0xD608);WriteData(0x00);
WriteComm(0xD609);WriteData(0xB1);
WriteComm(0xD60A);WriteData(0x00);
WriteComm(0xD60B);WriteData(0xD5);
WriteComm(0xD60C);WriteData(0x00);
WriteComm(0xD60D);WriteData(0xF4);
WriteComm(0xD60E);WriteData(0x01);
WriteComm(0xD60F);WriteData(0x23);
WriteComm(0xD610);WriteData(0x01);
WriteComm(0xD611);WriteData(0x49);
WriteComm(0xD612);WriteData(0x01);
WriteComm(0xD613);WriteData(0x87);
WriteComm(0xD614);WriteData(0x01);
WriteComm(0xD615);WriteData(0xB6);
WriteComm(0xD616);WriteData(0x02);
WriteComm(0xD617);WriteData(0x00);
WriteComm(0xD618);WriteData(0x02);
WriteComm(0xD619);WriteData(0x3B);
WriteComm(0xD61A);WriteData(0x02);
WriteComm(0xD61B);WriteData(0x3D);
WriteComm(0xD61C);WriteData(0x02);
WriteComm(0xD61D);WriteData(0x75);
WriteComm(0xD61E);WriteData(0x02);
WriteComm(0xD61F);WriteData(0xB1);
WriteComm(0xD620);WriteData(0x02);
WriteComm(0xD621);WriteData(0xD5);
WriteComm(0xD622);WriteData(0x03);
WriteComm(0xD623);WriteData(0x09);
WriteComm(0xD624);WriteData(0x03);
WriteComm(0xD625);WriteData(0x28);
WriteComm(0xD626);WriteData(0x03);
WriteComm(0xD627);WriteData(0x52);
WriteComm(0xD628);WriteData(0x03);
WriteComm(0xD629);WriteData(0x6B);
WriteComm(0xD62A);WriteData(0x03);
WriteComm(0xD62B);WriteData(0x8D);
WriteComm(0xD62C);WriteData(0x03);
WriteComm(0xD62D);WriteData(0xA2);

WriteComm(0xD62E);WriteData(0x03);
WriteComm(0xD62F);WriteData(0xBB);
WriteComm(0xD630);WriteData(0x03);
WriteComm(0xD631);WriteData(0xC1);
WriteComm(0xD632);WriteData(0x03);
WriteComm(0xD633);WriteData(0xC1);

//LV2 Page 0 enable

WriteComm(0xF000);WriteData(0x55);
WriteComm(0xF001);WriteData(0xAA);
WriteComm(0xF002);WriteData(0x52);
WriteComm(0xF003);WriteData(0x08);
WriteComm(0xF004);WriteData(0x00);

WriteComm(0xB000);WriteData(0x00);
WriteComm(0xB001);WriteData(0x05);
WriteComm(0xB002);WriteData(0x02);
WriteComm(0xB003);WriteData(0x05);
WriteComm(0xB004);WriteData(0x02);

//Source hold time

WriteComm(0xB600);WriteData(0x05);

//Gate EQ control

WriteComm(0xB700);WriteData(0x70);
WriteComm(0xB701);WriteData(0x70);

//Source EQ control (Mode 2)

WriteComm(0xB800);WriteData(0x01);
WriteComm(0xB801);WriteData(0x05);
WriteComm(0xB802);WriteData(0x05);
WriteComm(0xB803);WriteData(0x05);

//Inversion mode (2-dot)

WriteComm(0xBC00);WriteData(0x00);
WriteComm(0xBC01);WriteData(0x00);
WriteComm(0xBC02);WriteData(0x00);

//Timing control 4H w/ 4-Delay(

WriteComm(0xCC00);WriteData(0x03);

```
WriteComm(0xCC01);WriteData(0x50);  
WriteComm(0xCC02);WriteData(0x50);
```

```
WriteComm(0xBD00);WriteData(0x01);  
WriteComm(0xBD01);WriteData(0x84);  
WriteComm(0xBD02);WriteData(0x07);  
WriteComm(0xBD03);WriteData(0x31);  
WriteComm(0xBD04);WriteData(0x00);
```

```
WriteComm(0x3600);WriteData(0x80);  
WriteComm(0x3500);WriteData(0x00);  
WriteComm(0x3A00);WriteData(0x55); // 55
```

```
WriteComm(0x1100);  
Delay(120);  
WriteComm(0x2900);
```

```
}
```

```
Void Panel_SleepIn_Mode (void)
```

```
{  
Write command 0x10;  
Delays (120);  
}
```

```
Void Panel_SleepOut_Mode (void)
```

```
{  
Write command 0x11;  
Delays (120);  
}
```

--- END ---