

# SKM 400GB124D

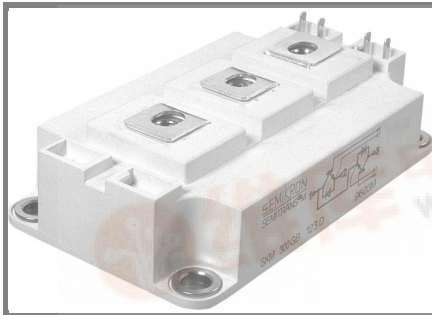

**SEMITRANS™ 3**

## Low Loss IGBT Modules

- SKM 400GB124D
- SKM 400GAL124D
- SKM 400GAR124D

### Features

- MOS input (voltage controlled)
- N channel, homogeneous Si-structure (NPT- Non punch-through IGBT)
- Low inductance case
- Very low tail current with low temperature dependence
- High short circuit capability, self limiting to  $6 \times I_{CNOM}$
- Latch-up free
- Fast & soft inverse CAL Diodes
- Isolated copper baseplate using DCB Direct Copper Bonding Technology without hard mould
- Large clearance (12 mm) and creepage distance (20 mm)

### Typical Applications

- Switching (not for lineal use)
- Inverter drives
- UPS

Absolute Maximum Ratings		$T_c = 25^\circ\text{C}$ , unless otherwise specified		
Symbol	Conditions	Values		Units
<b>IGBT</b>				
$V_{CES}$		1200		V
$I_C$	$T_c = 25 (80)^\circ\text{C}$	570 (400)		A
$I_{CRM}$	$t_p = 1 \text{ ms}$	600		A
$V_{GES}$		$\pm 20$		V
$T_{vj}$ , ( $T_{stg}$ )	$T_{OPERATION} \leq T_{stg}$	- 40 ... + 150 (125)		$^\circ\text{C}$
$V_{isol}$	AC, 1 min.	2500		V
<b>Inverse diode</b>				
$I_F$	$T_c = 25 (80)^\circ\text{C}$	390 (260)		A
$I_{FRM}$	$t_p = 1 \text{ ms}$	600		A
$I_{FSM}$	$t_p = 10 \text{ ms; sin.; } T_j = 150^\circ\text{C}$	2900		A
<b>Freewheeling diode</b>				
$I_F$	$T_c = 25 (80)^\circ\text{C}$	390 (260)		A
$I_{FRM}$	$t_p = 1 \text{ ms}$	600		A
$I_{FSM}$	$t_p = 10 \text{ ms; sin.; } T_j = 150^\circ\text{C}$	2900		A

Characteristics		$T_c = 25^\circ\text{C}$ , unless otherwise specified			
Symbol	Conditions	min.	typ.	max.	Units
<b>IGBT</b>					
$V_{GE(th)}$	$V_{GE} = V_{CE}, I_C = 12 \text{ mA}$	4,5	5,5	6,5	V
$I_{CES}$	$V_{GE} = 0, V_{CE} = V_{CES}, T_j = 25 (125)^\circ\text{C}$		0,2	0,6	mA
$V_{CE(TO)}$	$T_j = 25 (125)^\circ\text{C}$		1,1 (1,1)	1,25 (1,25)	V
$r_{CE}$	$V_{GE} = 15 \text{ V}, T_j = 25 (125)^\circ\text{C}$		3,3 (4,3)	4 (5,3)	m $\Omega$
$V_{CE(sat)}$	$I_{Cnom} = 300 \text{ A}, V_{GE} = 15 \text{ V}, \text{ chip level}$		2,1 (2,4)	2,45 (2,85)	V
$C_{ies}$	under following conditions		22	30	nF
$C_{oes}$	$V_{GE} = 0, V_{CE} = 25 \text{ V}, f = 1 \text{ MHz}$		3,3	4	nF
$C_{res}$			1,2	1,6	nF
$L_{CE}$				20	nH
$R_{CC+EE}$	res., terminal-chip $T_c = 25 (125)^\circ\text{C}$		0,35 (0,5)		m $\Omega$
$t_{d(on)}$	$V_{CC} = 600 \text{ V}, I_{Cnom} = 300 \text{ A}$		85		ns
$t_r$	$R_{Gon} = R_{Goff} = 5 \Omega, T_j = 125^\circ\text{C}$		65		ns
$t_{d(off)}$	$V_{GE} = \pm 15 \text{ V}$		680		ns
$t_f$			56		ns
$E_{on} (E_{off})$			36 (42)		mJ
<b>Inverse diode</b>					
$V_F = V_{EC}$	$I_{Fnom} = 300 \text{ A}; V_{GE} = 0 \text{ V}; T_j = 25 (125)^\circ\text{C}$		2 (1,8)	2,5	V
$V_{(TO)}$	$T_j = (125)^\circ\text{C}$		(1,1)	(1,2)	V
$r_T$	$T_j = (125)^\circ\text{C}$			(3,5)	m $\Omega$
$I_{RRM}$	$I_{Fnom} = 300 \text{ A}; T_j = (125)^\circ\text{C}$		(136)		A
$Q_{rr}$	$di/dt = \text{A}/\mu\text{s}$		36		$\mu\text{C}$
$E_{rr}$	$V_{GE} = \text{V}$				mJ
<b>FWD</b>					
$V_F = V_{EC}$	$I_F = 300 \text{ A}; V_{GE} = 0 \text{ V}, T_j = 25 (125)^\circ\text{C}$		2 (1,8)	2,5	V
$V_{(TO)}$	$T_j = (125)^\circ\text{C}$		(1,1)	(1,2)	V
$r_T$	$T_j = (125)^\circ\text{C}$			(3,5)	m $\Omega$
$I_{RRM}$	$I_F = 300 \text{ A}; T_j = (125)^\circ\text{C}$		(136)		A
$Q_{rr}$	$di/dt = \text{A}/\mu\text{s}$		36		$\mu\text{C}$
$E_{rr}$	$V_{GE} = \text{V}$				mJ
<b>Thermal characteristics</b>					
$R_{th(j-c)}$	per IGBT			0,05	K/W
$R_{th(j-c)D}$	per Inverse Diode			0,125	K/W
$R_{th(j-c)FD}$	per FWD			0,125	K/W
$R_{th(c-s)}$	per module			0,038	K/W
<b>Mechanical data</b>					
$M_s$	to heatsink M6	3		5	Nm
$M_t$	to terminals M6	2,5		5	Nm
w				325	g

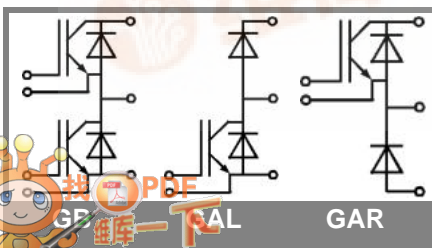

# SKM 400GB124D

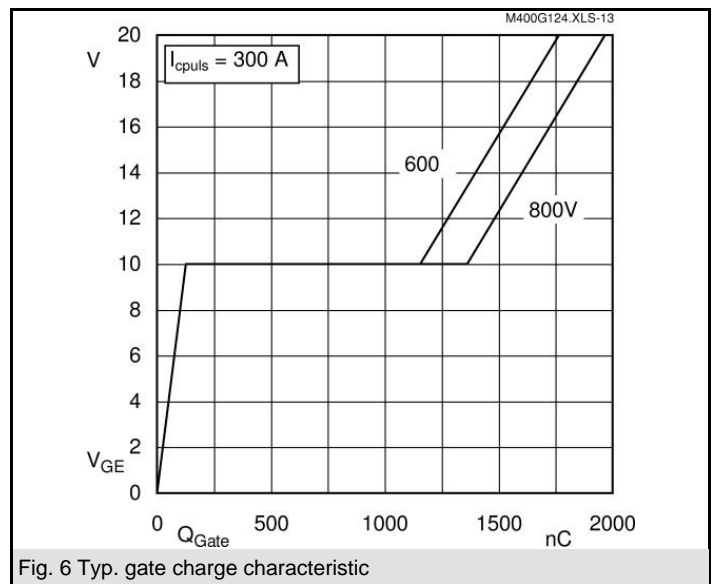
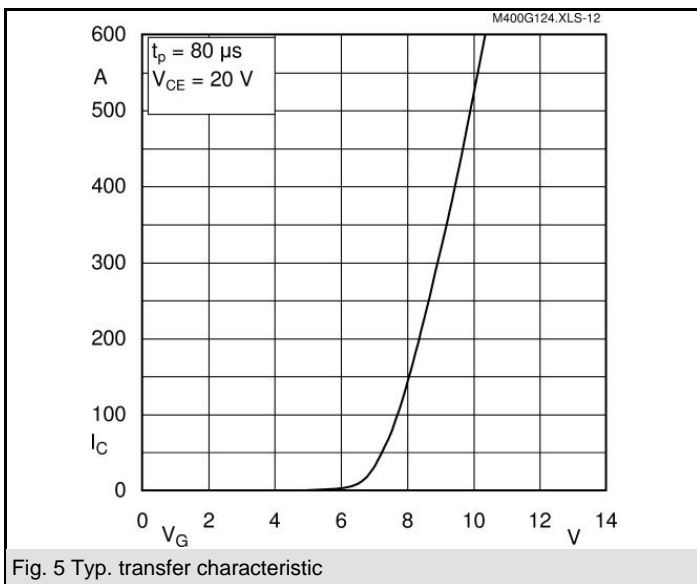
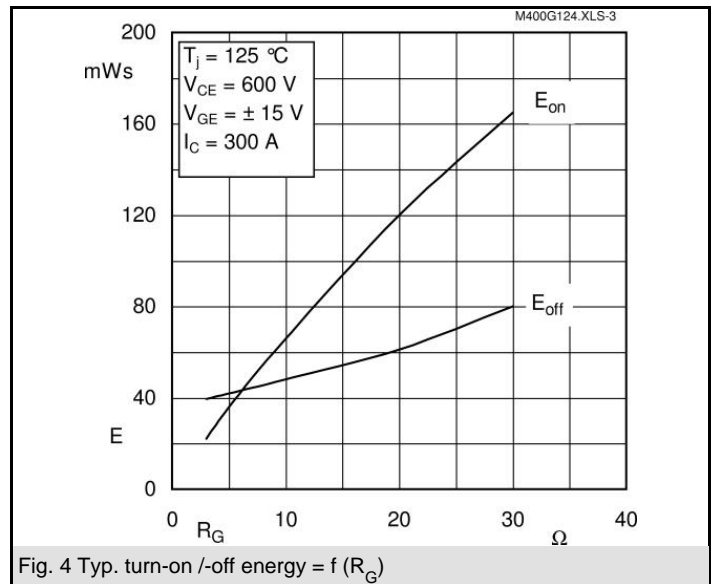
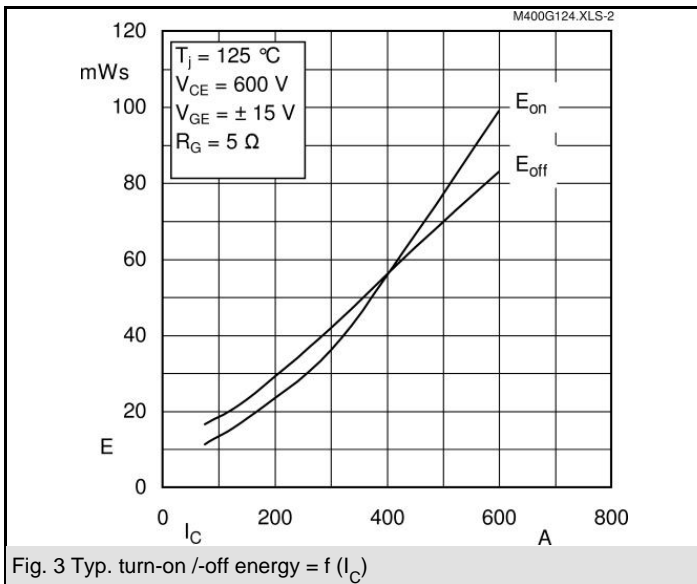
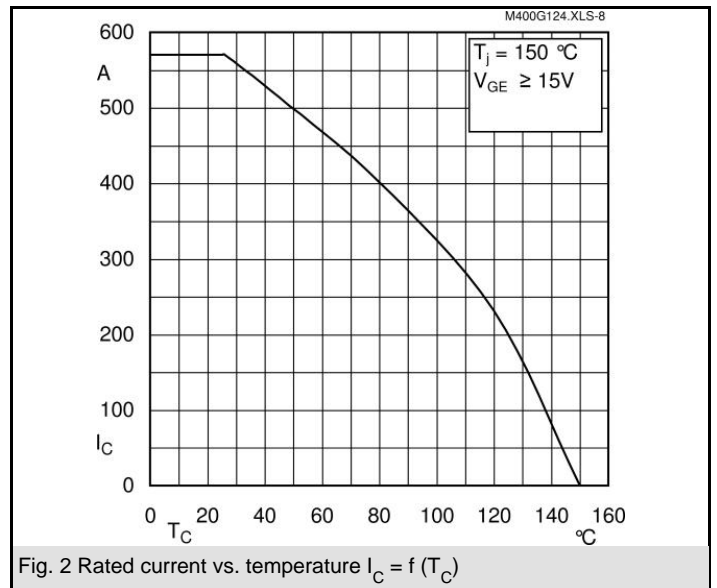
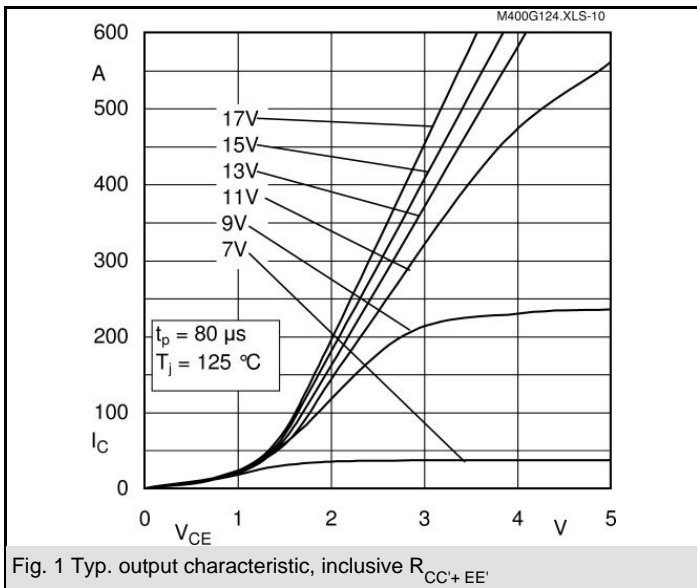

# SKM 400GB124D

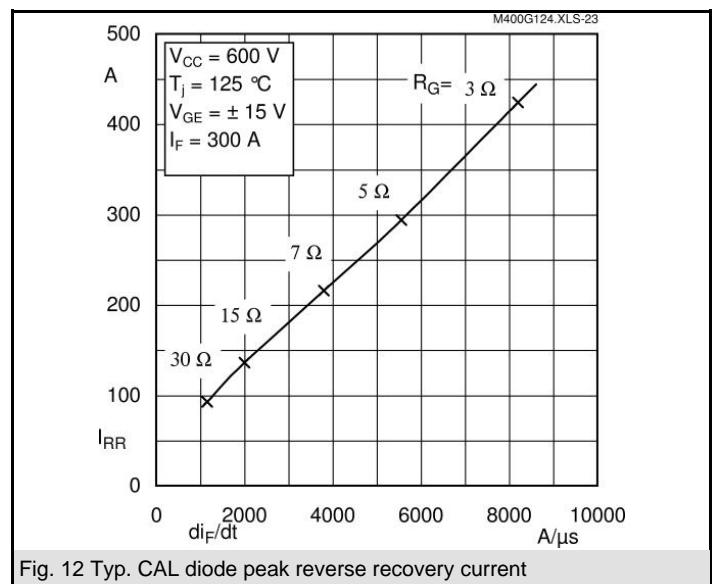
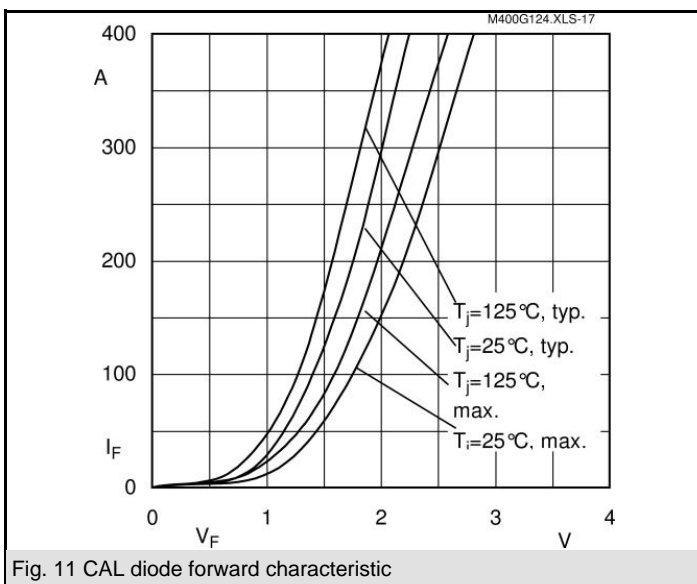
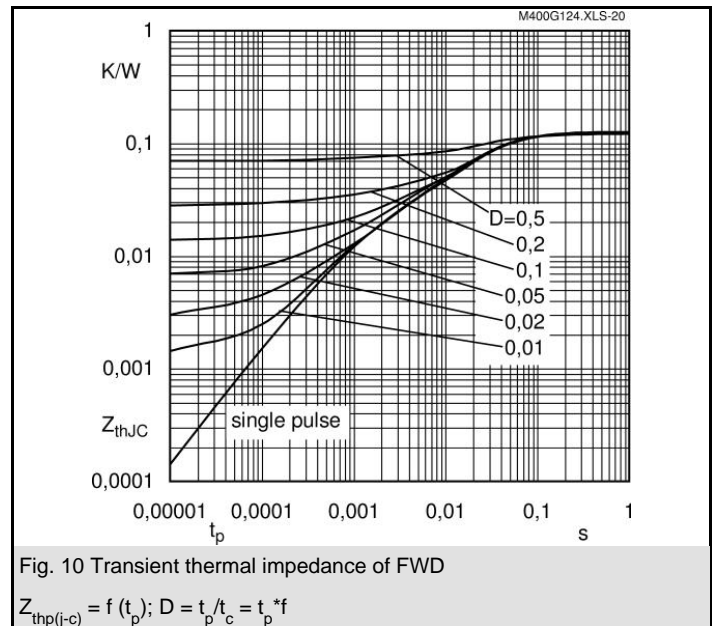
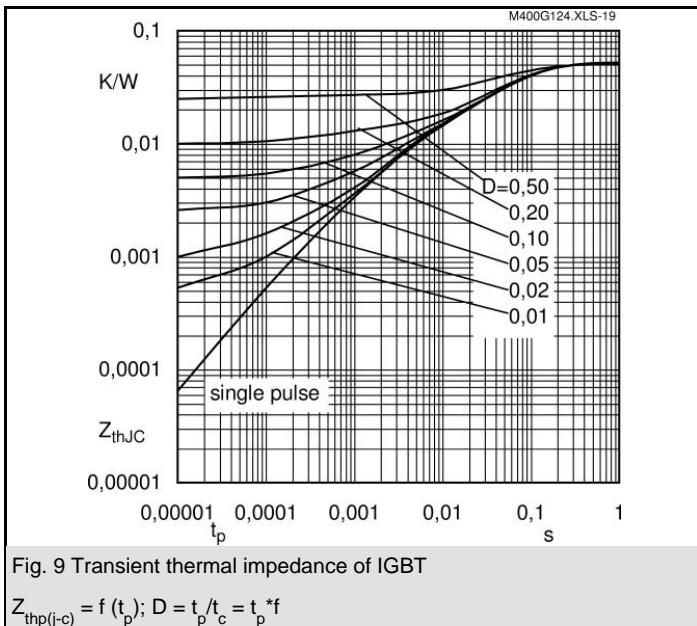
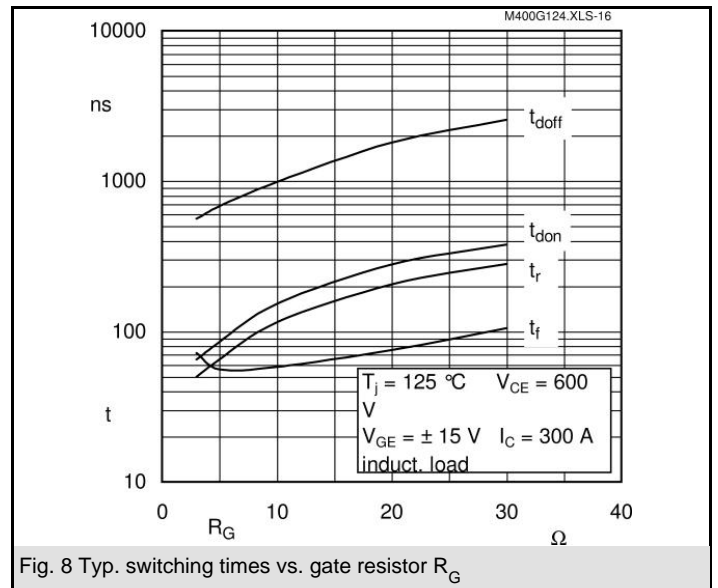
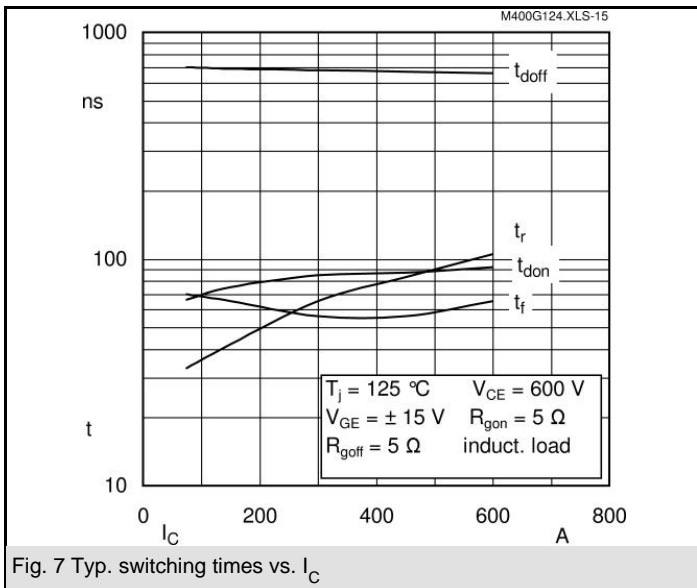

# SKM 400GB124D

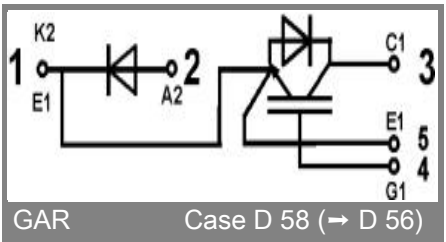
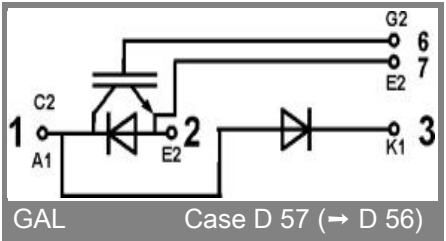
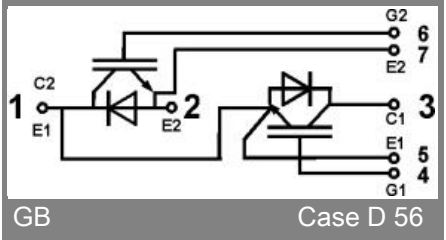
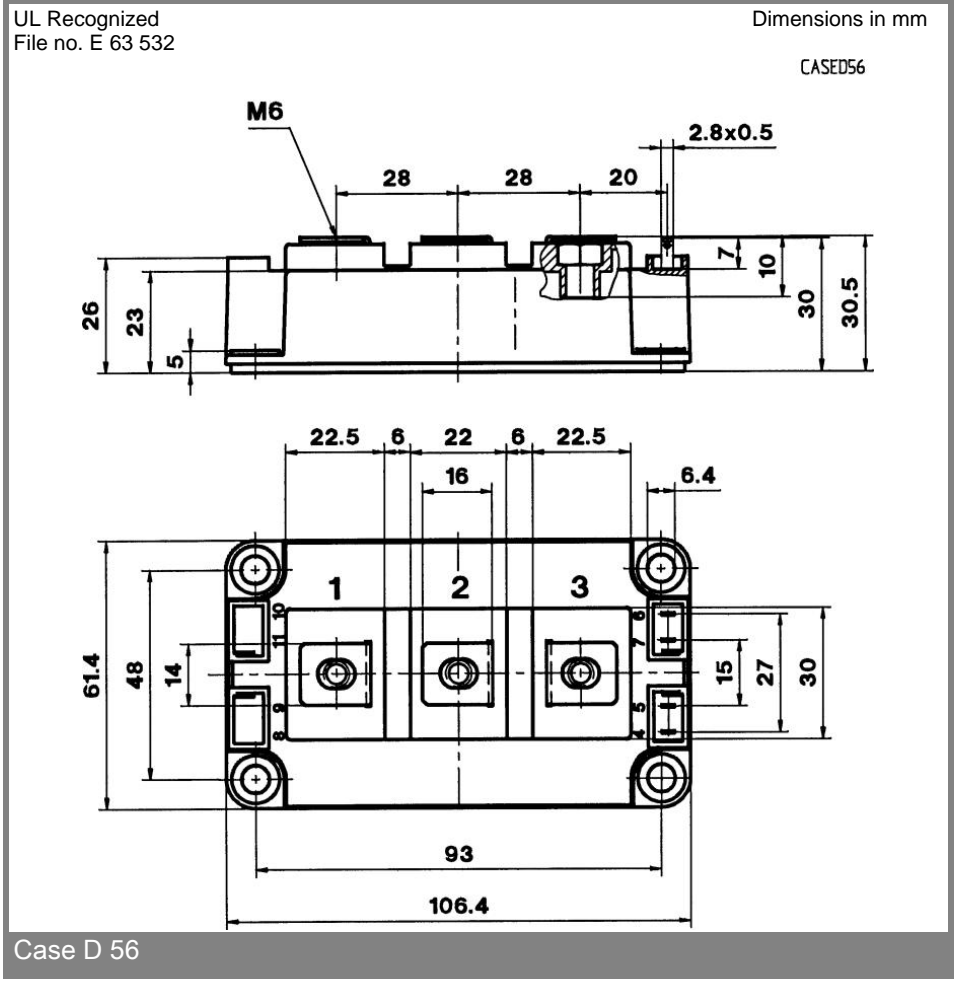
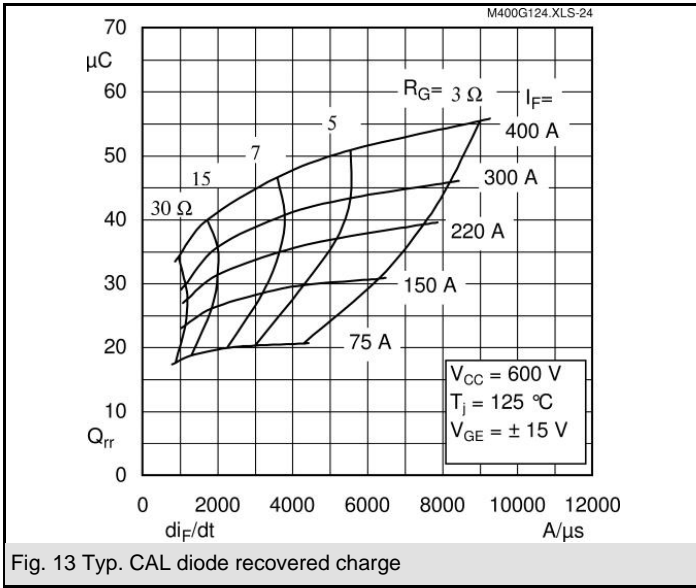

This is an electrostatic discharge sensitive device (ESDS), international standard IEC 60747-1, Chapter IX.

This technical information specifies semiconductor devices but promises no characteristics. No warranty or guarantee expressed or implied is made regarding delivery, performance or suitability.

Copyright © Each Manufacturing Company.

All Datasheets cannot be modified without permission.

This datasheet has been download from :

[www.AllDataSheet.com](http://www.AllDataSheet.com)

100% Free DataSheet Search Site.

Free Download.

No Register.

Fast Search System.

[www.AllDataSheet.com](http://www.AllDataSheet.com)