

Safety equipment for hydraulic accumulators



1. DESCRIPTION

1.1. GENERAL

Hydraulic accumulators are pressure equipment, as defined by the European Pressure Equipment Directive (PED), and as such their manufacture is subject to the statutory regulations.

For safety in the workplace, system manufacturers and operators must draw up risk assessments for the particular site. These must take possible risks at the installation site into account as well as risks in combination with external factors.

Fundamental risks affecting hydraulic accumulators are:

- Excessive pressure
- Temperature increase (e.g. in the event of an external fire)

HYDAC provides the appropriate safety equipment to protect hydraulic accumulators from the maximum permitted operating pressure PS being exceeded on the gas and fluid side; see also catalogue section:

- HYDAC Accumulator Technology No. 3.000

When selecting safety equipment, consideration must be given to the material (elastomers and housing material) in terms of the material compatibility with the application.

The response pressure of safety equipment must **not** exceed the max. permitted operating pressure PS of a hydraulic accumulator.

1.2. NOTICE

All work with HYDAC safety devices must only be carried out by suitably trained staff.

Incorrect installation or handling can lead to serious accidents.

The following operating instructions must be observed!

- Operating instructions GSV/GMP No. 3.504.BA
- Operating instructions GSB No. 3.505.BA

Further information such as accumulator sizing, safety information and extracts from the acceptance specifications can be found in the following catalogue section:

- HYDAC Accumulator Technology No. 3.000

Relevant PDF documents can be accessed at:
www.hydac.com » Downloads » Documents » Accumulator Division

2. PROTECTION ON THE GAS SIDE

2.1. BURST DISC

2.1.1 Design

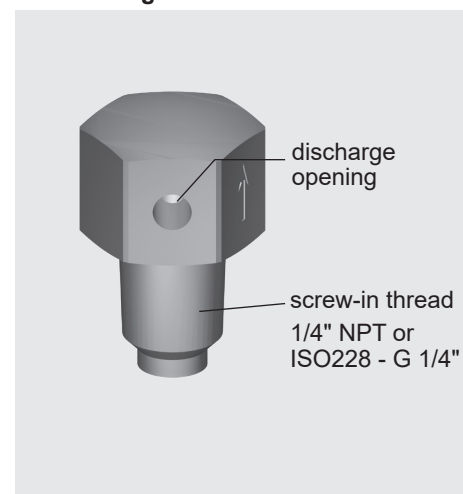

2.1.2 Function

If the pressure exceeds the permitted level, the burst disc is destroyed, permanently opening the port. This reduces the gas pressure by discharging the nitrogen completely.

Burst discs are designed for different response pressures and are supplied with a declaration of conformity.

Burst discs are made either entirely of stainless steel, or from an alloy based on stainless steel and nickel.

2.1.3 Standard types

Burst disc, welded, with declaration of conformity to PED DN5

Designation	Burst pressure ±10 % at 50 °C	Part no.
Burst disc plug 1/4" NPT	210 bar	3156148
	250 bar	3156150
	300 bar	3156151
	330 bar	3341280*
	350 bar	3156152
Burst disc plug ISO 228 G 1/4"	210 bar	3516441
	330 bar	3560189
	400 bar	3358418

* Preferred models

Others on request

Theoretically calculated values for the particular mass flow

Burst pressure [bar]	Mass flow [kg/h]
210	1950
250	2320
300	2782
330	3059
350	3244
400	3706

Burst disc, clamped, with declaration of conformity to ASME VIII, Div. 1 and VD stamp DN 15, 1/2" NPT on request

2.1.4 Adapter for bladder accumulators

To protect standard and low pressure bladder accumulators, the adapter shown below must be ordered with the burst disc:

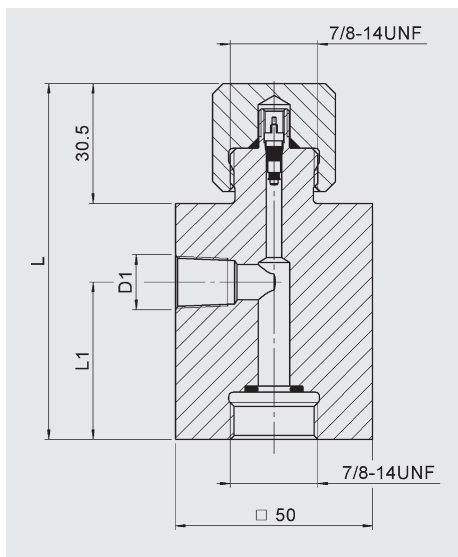

L [mm]	L1 [mm]	D1	Carbon steel	Stainless steel
90.5	40	1/4" NPT	366694	–
81.5	30	1/4" NPT	–	3117711
90.5	40	ISO 228 G 1/4"	364802	–
81.5	30	ISO 228 G 1/4"	–	3521154

2.1.5 Adapter for piston and diaphragm accumulators

To protect piston and diaphragm accumulators, the adapter shown below must be ordered with the burst disc:

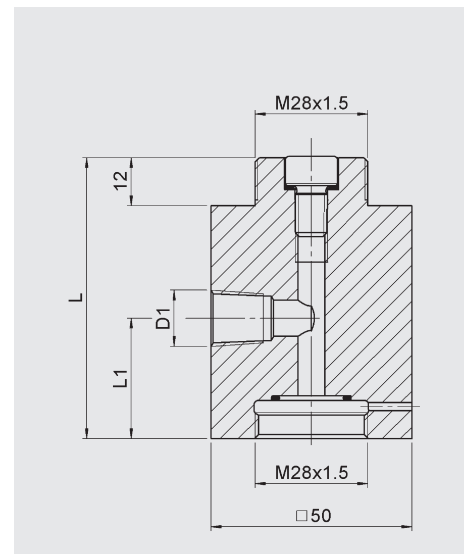

L [mm]	L1 [mm]	D1	Carbon steel	Stainless steel
70	30	1/4" NPT	3344645	–
		1/4" NPT	–	4329253
		ISO 228 G 1/4"	4286781	–
		ISO 228 G 1/4"	–	3564669

2.2. TEMPERATURE FUSE

HYDAC offers two different kinds of temperature fuse. In addition to the temperature fuse in carbon steel and stainless steel, which is suitable for bladder accumulators, HYDAC offers a type GMP6 temperature fuse, which is approved according to the European Pressure Equipment Directive (PED). It is made of stainless steel and has a CE marking.

2.2.1 Function

Temperature fuses are "devices with a safety function" and are used to release the gas pressure by discharging the nitrogen completely when an increase in temperature reaches unacceptable levels (e.g. in the case of fire).

2.2.2 Design/technical data/standard models

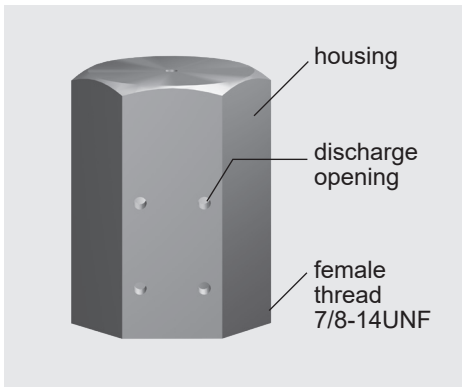
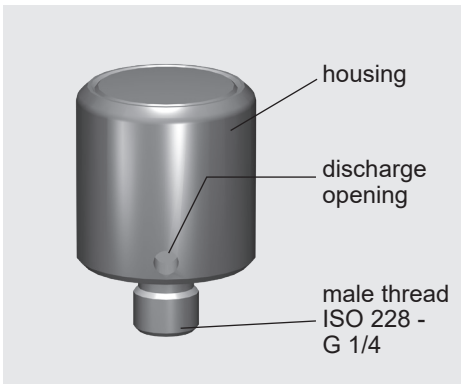
Type	Temperature fuse	GMP6 temperature fuse	
Design			
Permitted operating pressure	≤ 450 bar	50 ... 420 bar	
Temperature range	-10 °C ... +80 °C	-40 °C ... +120 °C	
Melting temperature	Between +160 °C and +170 °C	Between +160 °C and +170 °C	
CE marking	Not available	Available	
Standard types	363501* Temperature fuse 7/8-14UNF 3094166* Temperature fuse 7/8-14UNF with eye bolt (for crane hook)	3517438 3521196 3584817	GMP6-10-CE1637... GMP6-10-CE1637... with adapter for bladder accumulators GMP6-10-CE1637... with adapter for piston and diaphragm accumulators

* Preferred models

2.2.3 Installation instructions

See section 1.2.

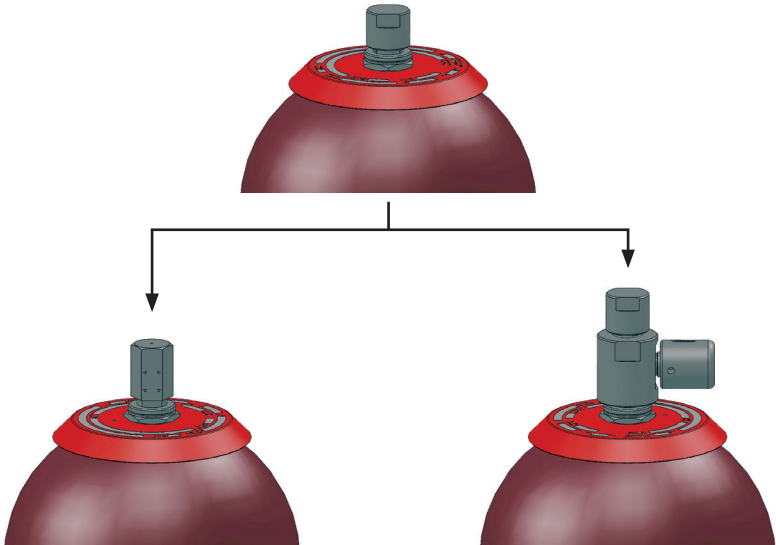
Type	Temperature fuse	GMP6 temperature fuse
	Simple to retrofit (using the example of a bladder accumulator) by replacing the sealing cap with the temperature fuse.	Simple to retrofit (using the example of a bladder accumulator) by replacing the sealing cap with the GMP6 temperature fuse with adapter.
Bladder accumulator without temperature fuse		
Temperature fuse or GMP6 temperature fuse and adapter		

2.3. GAS SAFETY VALVE

2.3.1 Design and dimensions

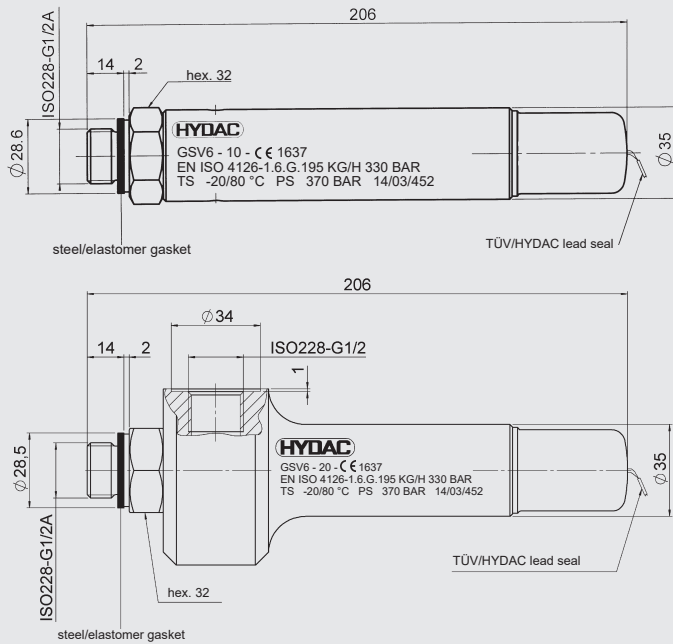

2.3.2 Function

The gas safety valve protects the hydraulic accumulator by reducing the pressure in a controlled way **if pressure exceeds the permitted level unexpectedly** (regular triggering of the GSV6 can lead to leakage at the valve). It is pre-set on the pressure side and lead-sealed by the authorised representative. It is also supplied with a declaration of conformity and a type approval.

2.3.3 Model code

(also order example)

GSV6 - 10 - CE1637.ENISO4126-1.6.G. 195. 330

Gas safety valve

Series

10 = Standard with 2 discharge openings nominal size 6 mm
20 = 1 discharge opening ISO 228 - G 1/2

Component code

Outlet mass flow Q_m [kg/h]

(see table, section 2.3.6)

Response pressure p [bar]

(see table, section 2.3.6)

2.3.4 Technical Data

Dimensioning

European Pressure Equipment Directive (PED), EN ISO4126-1, EN 764-7, others on request

Module category

IV to European Pressure Equipment Directive (PED)
Module B + D (EU-type examination)
Module G (unit verification) on request

Nominal size

6 mm

Outlet mass flow

See section 2.3.6

Material

Stainless steel, closing element with flexible seat seal

Medium

Nitrogen (N₂)

Operating pressure range

30 ... 370 bar

Temperature range

-20 °C ... +80 °C

Others on request

Weight

1.1 kg

2.3.5 Installing the GSV gas safety valve

The self-centring steel-elastomer seal ring means that this valve can be installed simply and securely in any position.

See section 1.2.

2.3.6 Standard types

Selection of the response pressure (p) of the gas safety valve is based on the maximum operating pressure of the hydraulic accumulator, according to the application.

Q _m [kg/h]	p [bar]	Part no. ¹⁾
15	30	3123965
20	40	3123966
28	50	3123967
35	60	3124028
40	70	3124029
45	80	3124030
50	90	3124031
58	100	3124032
65	110	3124033
70	120	3124034
75	130	3124035
83	140	3124036
88	150	3124037
95	160	3124038
100	170	3124039
105	180	3124040
110	190	3124041
118	200	3124042
125	210	3124043
130	220	3124044
135	230	3124045
140	240	3124046
148	250	3124047
155	260	3124048
160	270	3124049
165	280	3124050
170	290	3124051
178	300	3124052
185	310	3124053
190	320	3124054
195	330	3124055
200	340	3124056
205	350	3124057

¹⁾ Others on request

> 350 bar = additional price required for unit verification, please ask

2.3.7 Adapter for bladder accumulators

To protect standard and low pressure bladder accumulators, the adapter shown below must be ordered with the GSV6 gas safety valve.

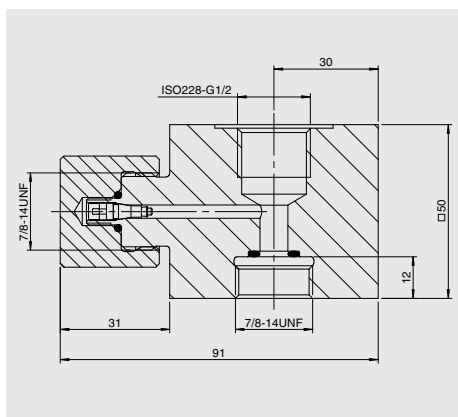

Designation	Part no.
Adapter assembly for bladder accumulators	2103381

Others on request

2.3.8 Adapter for piston and diaphragm accumulators

To protect piston and diaphragm accumulators, the adapter shown below must be ordered with the GSV6 gas safety valve:

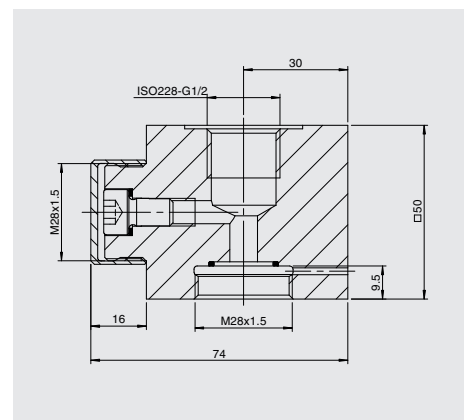

Designation	Part no.
Adapter assembly for piston and diaphragm accumulators	3423339

Others on request

2.4. GAS SAFETY BLOCK

2.4.1 Design

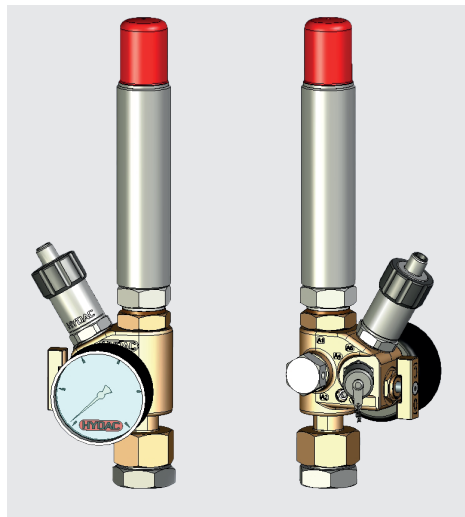

The GSB450 gas safety block consists of a brass block (other materials on request) with an integrated vent valve and shut-off valve and connections for:

- Pressure gauge
- Gas safety valve (GSV6)
- Gas charging valve (e.g. Minimess)
- Pressure transmitter or pressure switch
- Burst disc or temperature fuse

The gas safety valve connection is designed as a check valve. Therefore, the valve can be changed even if the system is pressurised.

2.4.2 Function

The GSB450 is an adapter block which is mounted on a hydraulic accumulator on the gas side and which can be fitted with various pressure devices, charging equipment, safety valves and other safety components.

2.4.3 Advantages

- Compact design
- Flexible connection options
- Variable indication options: bar, MPa or psi, analogue or digital (optional)
- The direction that the pressure indicator is facing can be individually adjusted
- Accumulator can be charged with nitrogen, directly via Minimess valve
- Pre-charge pressure can be checked without FPU-1

2.4.4 Model code (also order example)

GSB450 - 1 - 1 - 5 - 1 - 1 - 350

Series

Material

- 1 = standard
(brass and add-on parts in carbon steel)
- 2 = stainless steel
(brass and add-on parts in stainless steel)
- 3 = stainless steel
(on request)

Accumulator connection

- 1 = connection for SK/SBO
- 2 = connection for SB 7/8-14UNF
- 3 = connection for SB 5/8-18UNF
- 8 = connection for threaded pipe fitting DKS18
- 9 = special connection (on request)

Pressure gauge display

- 0 = none
- 1 = 0 - 25 bar
- 2 = 0 - 100 bar
- 3 = 0 - 160 bar
- 4 = 0 - 250 bar
- 5 = 0 - 400 bar
- 9 = special pressure gauge

Gas charging connection

- 0 = none
- 1 = Minimess valve M16x2 (NBR seal)
- 2 = Minimess valve M16x1.5 (FKM seal)
- 3 = Minimess valve M16x1.5 (gas-tight, stainless steel 1.4104)
for permanent monitoring (see section 2.4.6)
- 9 = special connection

Safety devices

- 0 = none
- 1 = GSV
- 2 = burst disc
- 3 = temperature fuse

Pressure range of the safety equipment

2.4.5 Technical Data

Medium

Nitrogen (N₂)

Permitted operating temperature

-20 °C ... +80 °C

Max. operating pressure

400 bar / 5800 psi

Accumulator connection

Bladder accumulator:
7/8-14UNF with adapter

For bladder accumulators, the appropriate adapter is supplied. All other connections are sealed with locking screws.

Piston and diaphragm accumulators:
M28x1.5

For piston and diaphragm accumulators the connection is a lock nut with M28x1.5 thread as standard.

Weight

- Standard design for SB
1.6 kg
- Standard design for SBO and SK
1.5 kg

2.4.6 Dimensions and versions

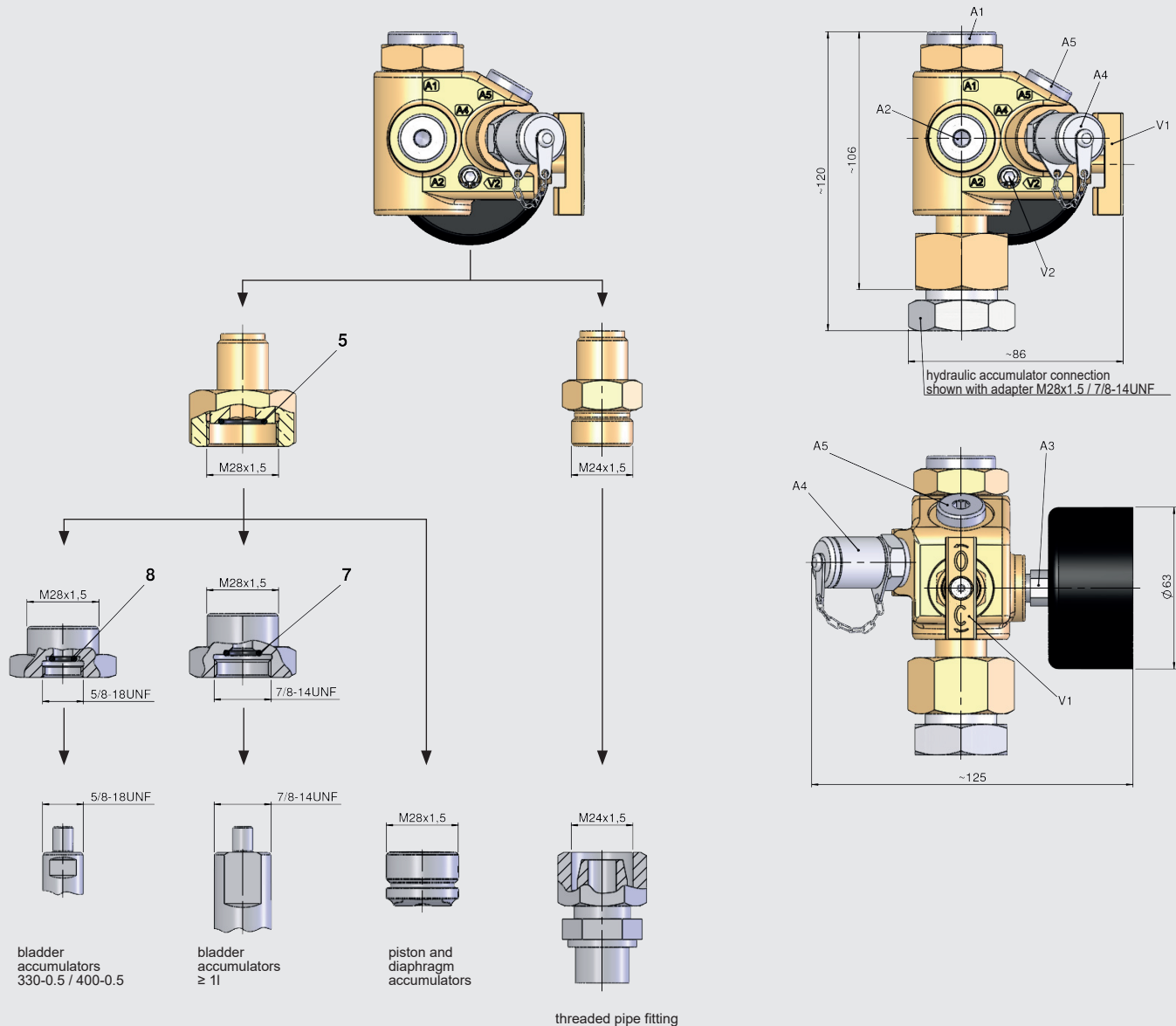

Standard model

The GSB450 is delivered with the following as standard:

- Shut-off valve
- Release valve
- Pressure gauge (0–400 bar, Ø 63 mm)
- Gas charging connection, code 1 (Minimesse threaded coupling, series 1620, M16x2)

The shut-off valve (V1) must always be closed following the charging and testing procedure to protect the pressure gauge (A3), Minimesse valve (A4) and pressure switch/pressure transmitter (A5) from a permanent pressure load. The pressure side must be depressurised at the release valve (V2).

If a pressure switch/pressure transmitter for permanent monitoring of the accumulator pre-charge pressure is screwed in at connection A5, the shut-off valve (V1) must be open. We recommend the gas charging connection with code 3 for this – see also Options.

Options

The GSB450 can be supplied with the following options*:

- Special pressure gauge, e.g.
 - units other than bar/psi
 - glycerin-filled
- Minimesse gas charging valve with code 3 for permanent monitoring (series 1615, M16x1.5, stainless steel version)
- Version where all steel parts are stainless steel (A4)
- Safety devices (GSV6 gas safety valve, burst disc, temperature fuse)

* On request and must be ordered separately and at additional cost

2.4.7 Standard types

Designation	Part no.
GSB450-1-1-1-1-0	3534710
GSB450-1-1-2-1-0	3534711
GSB450-1-1-3-1-0	3534712
GSB450-1-1-4-1-0	3528946
GSB450-1-1-5-1-0	3426882
GSB450-1-2-1-1-0	3534713
GSB450-1-2-2-1-0	3534714
GSB450-1-2-3-1-0	3484861
GSB450-1-2-4-1-0	3433824
GSB450-1-2-5-1-0	3426905

2.4.8 Installation of GSB gas safety block

See section 1.2.

2.4.9 Accessories

Block connections

Ports	Size	Standard configuration	Optional configuration
A1	ISO 228 - G1/2	Blanking plug	GSV6 gas safety valve
A2	ISO 228 - G1/4	Blanking plug	<ul style="list-style-type: none"> ● Remote charging (added by the customer) ● Burst disc ● Temperature fuse
A3		Pressure gauge 0–400 bar	<ul style="list-style-type: none"> ● For other measuring ranges, see section 2.4.4 ● Special pressure gauge (please specify)
A4		Minimess valve M16x2	Minimess valve M16x1.5 (various versions possible, please request, see section 2.4.4)
A5		Blanking plug	Pressure transmitter e.g. HYDAC HDA, EDS

Valves

Type	Description
V1	Shut-off valve
V2	Release valve (int. hex. AF 4)

Charging hoses

Charging hoses are designed for the particular maximum permitted operating pressure marked on them and 10,000 charging processes.

(HYDAC charging hoses comply with DIN EN ISO 4413 and DIN EN 853 to 857)

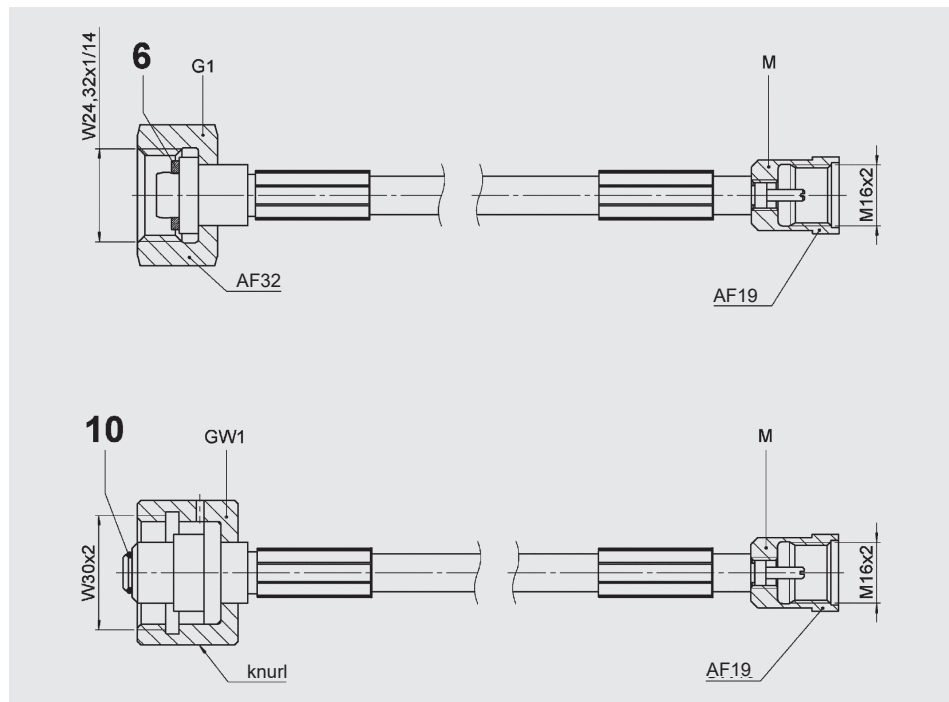

Gas connection of nitrogen bottles	Minimess connection	Length [m]	Part no.
W30x2	M16x2	2.5	3434454
		4	3434457
W24.32x1/14	M16x2	2.5	3434424
		4	3434451
		10	3526858

Suitable adapters for foreign nitrogen bottles can be found in the following catalogue section:

- FPU charging and testing unit No. 3.501

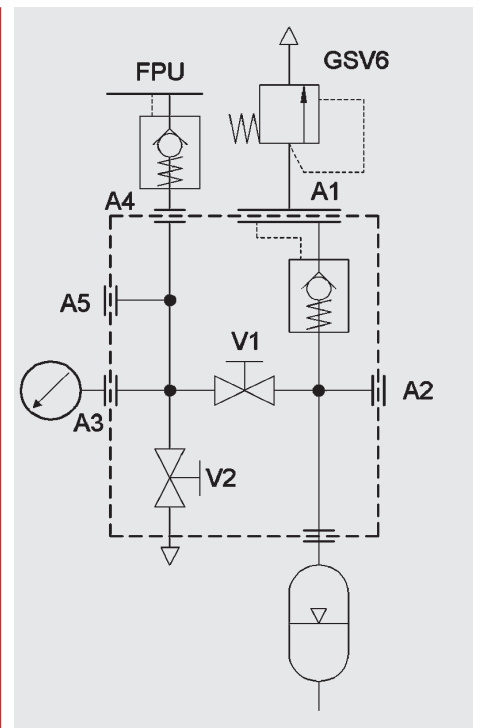

2.4.10 Spare parts

The following spare parts for GSB450 relate to the standard version:

carbon steel/NBR

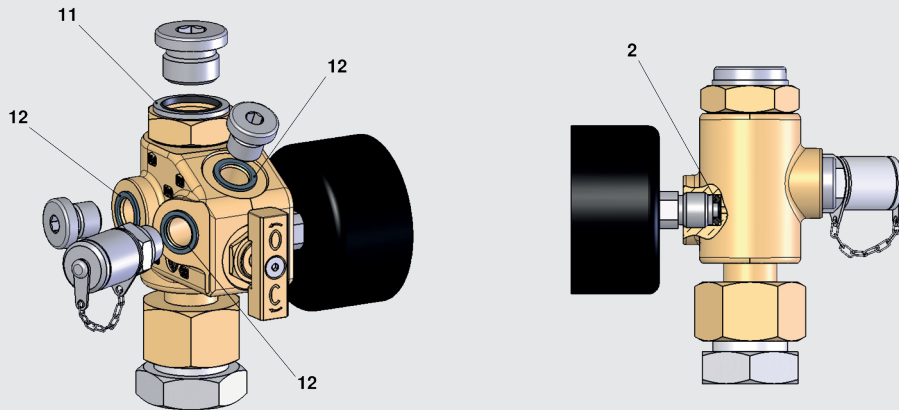

Description	Quantity	Item	Part no.
Seal kit for GSB450 consisting of:	1	–	4024196
Rhombic seal 1/4"	1	2	–
O-ring 15x2	1	5	–
Seal ring	1	6	–
O-ring 11x2	1	7	–
O-ring 9x2	1	8	–
O-ring 5.7x1.9	1	10	–
Seal ring	1	11	–
Seal ring	3	12	–
Pressure gauge	1	3	0 - 10 bar
			0 - 25 bar
			0 - 100 bar
			0 - 250 bar
			0 - 400 bar
			635139
			635140
			635141
			635142
			635143

3. PROTECTION ON THE FLUID SIDE

3.1. GENERAL

The fluid side must be protected from pressures exceeding the permitted operating pressures by installing approved and appropriate safety valves.

HYDAC offers pressure relief valves (DB12) which have a response pressure of up to 400 bar (set by HYDAC). The valve bears the CE marking, is built into safety and shut-off blocks in the series DSV10 and SAF in nominal sizes DN10 to DN50 and is lead-sealed.

Further information is available from the following catalogue section:

- SAF/DSV Safety and Shut-off Block No. 3.551

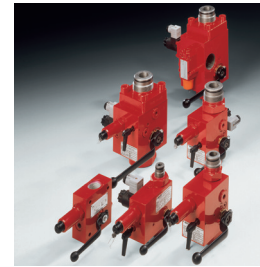

4. NOTE

The information in this brochure relates to the operating conditions and fields of application described. For applications and/or operating conditions not described, please contact the relevant technical department. Subject to technical modifications.

HYDAC Technology GmbH

Industriegebiet

66280 Sulzbach/Saar, Germany

Tel.: +49 (0) 68 97 / 509 - 01

Fax: +49 (0) 68 97 / 509 - 464

Internet: www.hydac.com

E-mail: speichertechnik@hydac.com

