

ASD 开关柜综合测控装置
ASD switch cabinet integrated measuring
and control device

安装使用说明书 V2.6

Installation and operation instruction V2.6

申 明

DECLARATION

版权所有，未经本公司之书面许可，此手册中任何段落，章节内容均不得被摘抄、拷贝或以任何形式复制、传播，否则一切后果由违者自负。

本公司保留一切法律权利。

No part of this publication may be reproduced, stored in a retrieval system, or transmitted in any form by any means, electronic, mechanical photocopying, recording, or otherwise without prior permission of Acrel. All rights reserved.

本公司保留对本手册所描述之产品规格进行修改的权利，恕不另行通知。

订货前，请垂询当地代理商以获悉本产品的最新规格。

This company reserve power of revision of product specification described in this manual, without notice. Before ordering, please consult local agent for the latest specification of product.

目 录

Contents

1 安装使用指南	1
1 Installation and operation guide	1
1.1 产品概述	1
1.1 Product overview	1
1.2 型号说明	1
1.2 Description of types	1
1.3 产品型号及功能	3
1.3 Product model and function	3
1.4 技术指标	4
1.4 Technical indexes	4
1.5 产品安装	5
1.5 Product installation	5
1.5.1 安装方法	6
1.5.1 Installation method	6
1.5.2 开孔尺寸（单位：毫米）	7
1.5.2 Hole size (unit: mm)	7
1.5.3 温湿度传感器、无线温度收发器的安装	7
1.5.3 Installation of temperature and humidity sensor, wireless temperature transceiver	7
1.5.4 无线温度传感器的安装	8
1.5.4 Installation of wireless temperature transceiver	8
1.6 接线方法	11
1.6 Wiring method	11
1.6.1 接线端子	11
1.6.1 Wiring terminal	11
1.6.2 典型接线图	13
1.6.2 Typical wiring diagram	13
2 产品操作指南	15
2 Product operation guide	15
2.1 显示介绍(ASD300)	15
2.1 Display introduction (ASD300)	15
2.2 操作介绍	16
2.2 Operation introduction	16
2.2.1 装置上电	16
2.2.1 Device power-on	16
2.2.2 动态模拟图	16
2.2.2 Dynamic mimetic diagram	16
2.2.3 高压带电显示及闭锁	17
2.2.3 HV live displaying and lock	17
2.2.4 报警继电器输出	18
2.2.4 Alarm relay output	18

2.2.5 自动温湿度控制	18
2.2.5 Auto temperature and humidity control	18
2.2.6 无线测温 (ASD300/ASD320 可选功能)	19
2.2.6 Wireless temperature measurement (ASD300/ASD320 optional functions)	19
2.2.7 智能语音防误提示 (ASD200、ASD300、ASD310、ASD320)	20
2.2.7 Intelligent voice error-preventing prompt (ASD200、ASD300、ASD310、ASD320)	20
2.2.8 柜内照明功能 (ASD200、ASD300、ASD310、ASD320)	21
2.2.8 Cabinet lighting function (ASD200, ASD300, ASD310, ASD320)	21
2.2.9 人体感应(ASD200、ASD300、ASD310、ASD320)	21
2.2.9 Human body induction (ASD200, ASD300, ASD310, ASD320)	21
2.2.10 电力参数测量(ASD300)	22
2.2.10 Electric power parameter measurement (ASD300)	22
2.2.11 带电显示自检 (ASD100G、ASD200、ASD300、ASD310、ASD320)	22
2.2.11 Self-inspection of live displaying (ASD100G, ASD200, ASD300, ASD310, ASD320)	22
2.2.12 核相功能 (ASD100G、ASD200、ASD300、ASD310、ASD320)	22
2.2.12 Nuclear phase function (ASD100G, ASD200, ASD300, ASD310, ASD320)	22
2.3 ASD300 编程设置	23
2.3 ASD300 programming setting	23
2.4 ASD200 编程设置	27
2.4 ASD200 programming setting	27
3 通讯指南	28
3 Communication guide	28
3.1 通讯格式详解	29
3.1 Detailed explanation of communication format	29
3.1.1 读取数据 (功能码 03H/04H)	29
3.1.1 Reading data (function code 03H/04H)	29
3.1.2 预置单个寄存器 (功能码 06H)	29
3.1.2 Preset single register (function code 06H)	29
3.1.3 预置多个寄存器 (功能码 10H)	30
3.1.3 Preset several registers (function code 10H)	30
3.2 参量地址表	30
3.2 Parameter address table	30
4 常见故障的诊断分析与排除方法	40
4 Diagnostic analysis and troubleshooting of common faults	40
4.1 辅助电源故障	40
4.1 Fault of auxiliary power supply	40
4.2 环境温湿度显示故障	40
4.2 Fault of environment temperature and humidity display	40
4.3 告警继电器动作故障	40
4.3 Fault of alarm relay operation	40
4.4 一次模拟状态指示灯故障	41
4.4 Fault of primary simulated status indicator light	41

4.5 通信故障.....	41
4.5 Communication fault.....	41
4.6 节点温度值显示故障.....	41
4.6 Fault of node temperature value display.....	41

1 安装使用指南

1 Installation and operation guide

1.1 产品概述

1.1 Product overview

ASD 系列开关柜综合测控装置用于 3~35kV 户内开关柜，适用于中置柜、手车柜、固定柜、环网柜等多种开关柜。具有一次回路模拟图及开关状态指示，高压带电显示及核相，自动温湿度控制，加热回路故障告警，分合闸回路完好指示、分合闸回路电压测量、预分预合闪光指示、电气节点无线测温，人体感应自动照明，语音提示，电参数测量及 RS485 通讯接口等众多功能，集操作、显示于一体。产品按功能分为 ASD100L、ASD100G、ASD200、ASD300、ASD310、ASD320 六种型号。

ASD series switch cabinet integrated measuring and control device is used for 3-35kV indoor switch cabinet, applying to centrally installed switchgear, trolley cabinet, fixed switchgear, ring main unit and other various switch cabinets. With primary circuit mimetic diagram and switch status indicator, HV live displaying and nuclear phase, automatic temperature and humidity control, heating circuit fault alarm, wireless temperature measurement, tripping circuit and closing circuit supervising, tripping circuit and closing circuit control voltage measurement, pre-tripping circuit and pre-closing indication, body induction auto lighting, voice prompt, electrical parameter measurement and RS485 communication interface and other numerous functions, it has integrated operation and display into one. The product is classified into ASD100L, ASD100G, ASD200, ASD300, ASD310, ASD320 six models according to its function.

1.2 型号说明

1.2 Description of types



图 1.1 ASD 系列产品命名规则

Figure 1.1 ASD Series Product naming rule

1.3 产品型号及功能

1.3 Product model and function

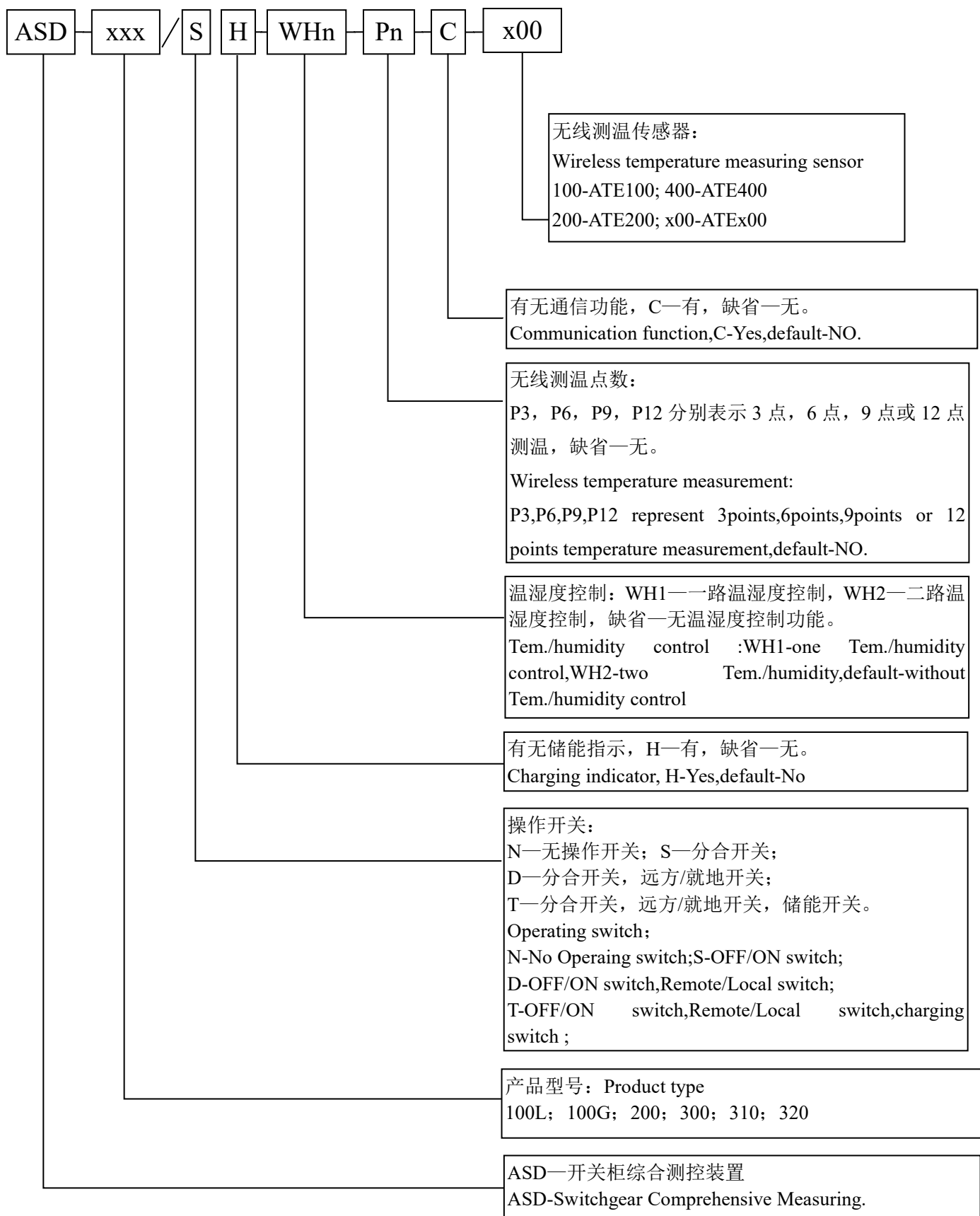
表 1 ASD 系列产品型号及功能

Table 1 ASD Series Product specification and functions

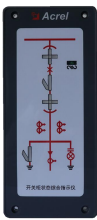
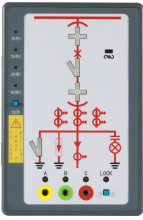
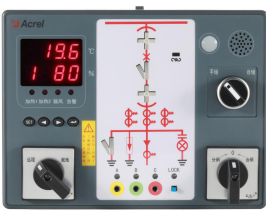
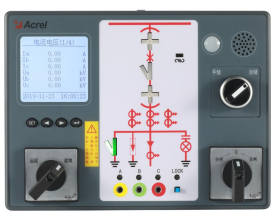
型号Type 功能项 function	ASD100L	ASD100G	ASD200	ASD300	ASD310	ASD320
产品图片 Product picture						
开孔尺寸 Cut-out dimensions	73mm×161mm	112mm×172mm	220mm×165mm			
一次模拟图 Primary circuit analog chart	标配 Standard					
带电显示 及自检/核相 Live display and self-test/nuclear phase	无 None	标配 Standard				
电磁闭锁出口 Electromagnetic lockout outlet	无 None	两路 Configuration 2	一路 Configuration 1			
温湿度控制 Temp./humidity control	无 None	标配 1 路传感器, 线长 4 米 Standard 1 sensor, line length 4 meters				
		两路加热 TWO heating	两路加热, 一路鼓风 TWO heating, One blowing			
强制加热 Forced heating	无 None	标配 Standard	标配 Standard			
加热回路 故障告警 Heating circuit Fault alarm	无 None	标配 Standard	标配 Standard			
断电告警 Power off alarm	无 None	标配 Standard	标配 Standard			
语音提示 Voice prompts	无 None	无 None	标配 Standard			
人体感应探头 Sensing probe for humanbody	无 None	无 None	标配 Standard			
操作旋钮 Operating knob	无 None	无 None	可选 Optional			

断路器分合次数显示 Beaker frequency shows	无 None	无 None	标配 Standard			
预分预合闪光指示 pre-tripping circuit and pre-closing indication	无 None	无 None	可选 Optional (该功能仅限于配有带预分、预合功能的操作开关装置) (This function only takes effect when there is a pre-tripping circuit and pre-closing indication switch)			
分闸、合闸完好指示 tripping circuit and closing circuit supervising,	无 None	无 None	标配 Standard			
分合闸回路电压测量 tripping circuit and closing circuit control voltage measurement	无 None	无 None	标配 Standard			
无线测温 Wireless temperature measurement	无 None	无 None	无 None	可选 Optional	无 None	标配 3 点 Standard : 3 points
主回路电力参数测量 Measure and display of power parameter	无 None	无 None	无 None	标配 Standard	无 None	
RS485 通讯接口 Communication port	无 None	标配 Standard				

1.4 技术指标

1.4 Technical indexes

表 2 ASD 系列技术指标

Table2 ASD Series Technical data

项目 Item		指标 Value					
		ASD100L	ASD100G	ASD200	ASD300	ASD310	ASD320
额定输入 Rated input	接线方式 Wiring mode	---	---	---	3P3L 或 3P4L 3P3L or 3P4L	---	---
	电压 Voltage	---	---	---	100V	---	---
	电流 Current	---	---	---	5A	---	---
	频率 frequency	---	---	---	50Hz	---	---
准确度 Accuracy rating	电流、电压 Current、Voltage	---	---	---	0.5 级 0.5 class	---	---
	有功功率 Active power	---	---	---	0.5 级 0.5class	---	---
	无功功率 Reactive power	---	---	---	0.5 级 0.5 class	---	---
	电能 Energy	---	---	---	0.5 级 0.5 class	---	---

	分合闸回路电压 tripping circuit and closing circuit control voltage	—	—	1 级 1 class		
	环境温度 Environment temperature	—	±1℃			
	相对湿度 Relative humidity	—	±3%			
装置工作电源 Device Working power		AC 85~265V, DC 100~300V				
功耗 Power consumption	辅助电源 Auxiliary power	≤5VA	≤5VA	≤6VA	≤8VA	
	电压输入 Voltage input	—	—	—	≤0.5VA	—
	电流输入 Current input	—	—	—	≤1VA	—
通讯 Communication	协议 protocol	—	MODBUS-RTU			
	波特率(bps) Baud rate(bps)	—	2400、4800、9600、19200			
无线测温 Wireless temperature measurement	测温范围 Temperature measurement range	—	—	-50℃~+125℃	—	-50℃~+125℃
	测温精度 Temperature measurement accuracy	—	—	±1℃	—	±1℃
	传感器电池寿命 Sensor battery life	—	—	≥5 年 ≥5 year	—	≥5 年 ≥5 year
	传感器启动电流 starting current	—	—	≥5A	—	≥5A
环境要求 Environmental requirement	工作温度 Operating temperature	-10℃~55℃				
	相对湿度 Relative humidity	≤95%				
平均无故障工作时间 Average work time without stoppage		≥50000 小时 ≥50000 hour				

1.5 产品安装

1.5 Product installation

ASD 系列开关柜综合测控装置采用面板嵌入式安装，首先柜体盘面上制作规定尺寸的长方形槽孔，装置取下支架后嵌入槽孔，再用支架固定即可。

Panel embedded installation is adopted for ASD series switch cabinet integrated measuring and control device: firstly fabricate rectangular slot with stipulated size on cabinet face; embed the device into the slot after taking down the support and then fix by support.

1.5.1 安装方法

1.5.1 Installation method



图 1.2 ASD100G 安装方法

Figure 1.2 Installation method of ASD100G

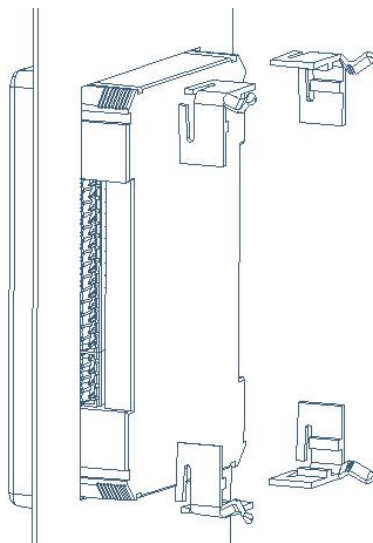

图 1.3 ASD200、ASD300、ASD310、ASD320 安装方法

Figure 1.3 Installation method of ASD200, ASD300, ASD310, ASD320

1.5.2 开孔尺寸 (单位: 毫米)

1.5.2 Hole size (unit: mm)

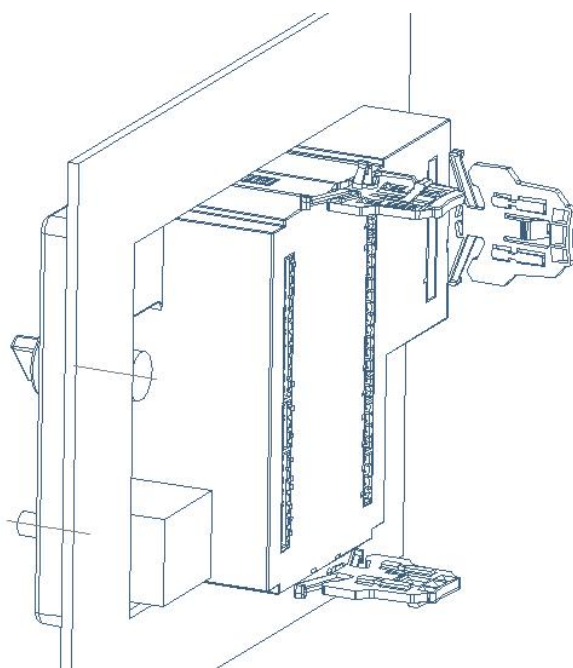

图 1.4 ASD100L 开孔尺寸图

Figure 1.4 Hole size diagram of ASD100L

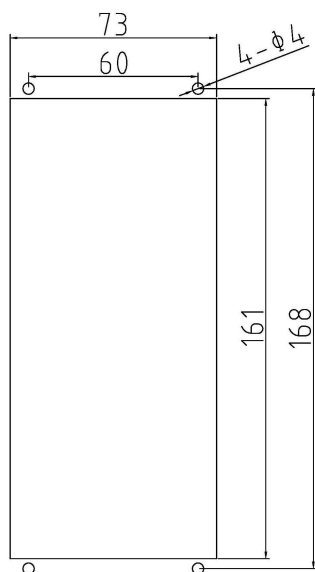

图 1.5 ASD100G 开孔尺寸图

Figure 1.5 Hole size diagram of ASD100G

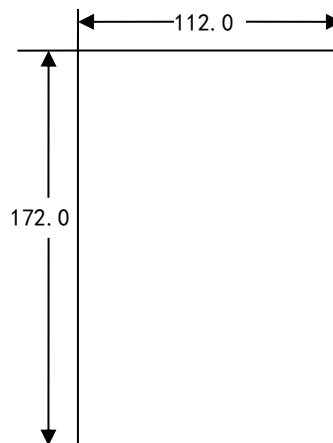

图 1.6 ASD200、ASD300、ASD310、ASD320 开孔尺寸

Figure 1.6 Hole size diagram of ASD200, ASD300, ASD310, ASD320

1.5.3 温湿度传感器、无线温度收发器的安装

1.5.3 Installation of temperature and humidity sensor, wireless temperature transceiver

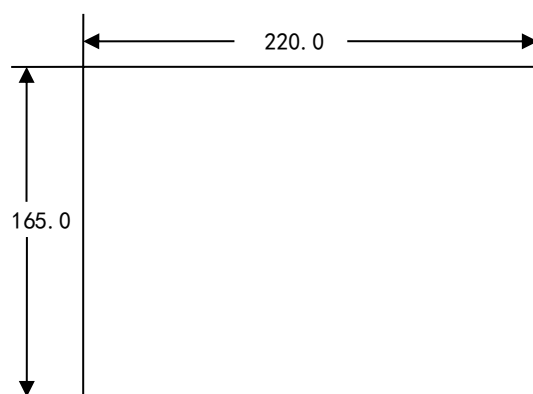
与 ASD 系列产品配套使用的温湿度传感器, 可以采用导轨 (DIN35mm) 安装方式, 也可以使用螺栓固定方式; 无线测温接收器直接安装在 ASD 的无线测温接口 (61~64), 并连接好天线; 产品尺寸外观如图 1.7 所示。

The temperature and humidity sensor used as ancillary with ASD series products can adopt guide rail (DIN35mm) installation or bolt fixing; the wireless temperature transceiver is directly installed on the wireless temperature measurement interface (61 ~ 64) of ASD and connected with the antenna; as shown in Figure 1.7.



图 1.7 温湿度传感器和无线温度收发器

Figure 1.7 Temperature and humidity sensor and wireless temperature transceiver

1.5.4 无线温度传感器的安装

1.5.4 Installation of wireless temperature transceiver

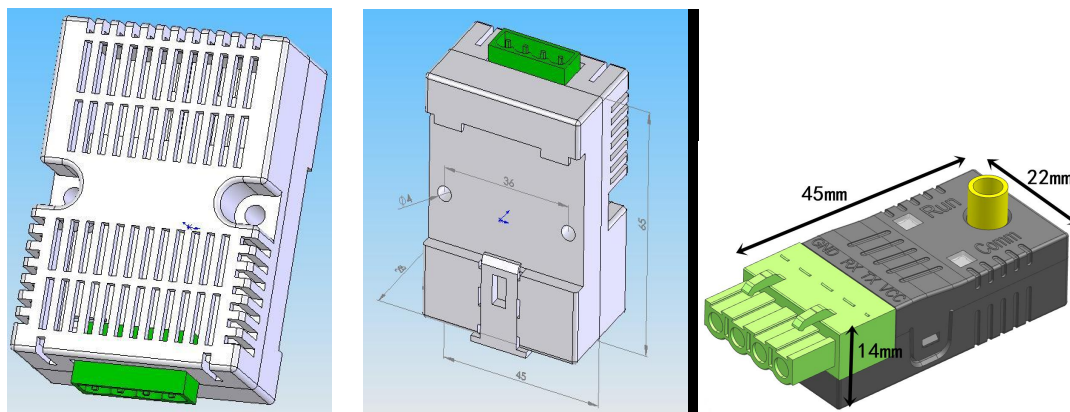
无线温度传感器共有多种型号，分别对应螺栓固定、表带固定、扎带捆绑、合金片固定等安装方式。

There are several types of wireless temperature sensors and mounting methods correspondingly, i.e. bolted type, strap-secured type, tied type and alloy chip fixed type.

Parameter Type	wireless temperature sensors			
	ATE100M	ATE100	ATE200	ATE400
Power supply	Battery			CT inductive powered
Wireless frequency	470MHz			470MHz
Sampling frequency	25s			15s
Transmission frequency	25s-5min			15s
Range of temperature	-50℃~+125℃			
Accuracy	±1℃			
Transmission distance	150m in open area			
Service life	>5 years(battery life at 25℃)			>10 years
Installation	Magnetic	Bolted	Belt	Tied with cable tie
Application	Between bus bar and cable joints			Bus bar, cable joints and fixed contact



图 1.8 表带式无线温度传感器 ATE200

Figure 1.8 Strap-secured wireless temperature sensor ATE200

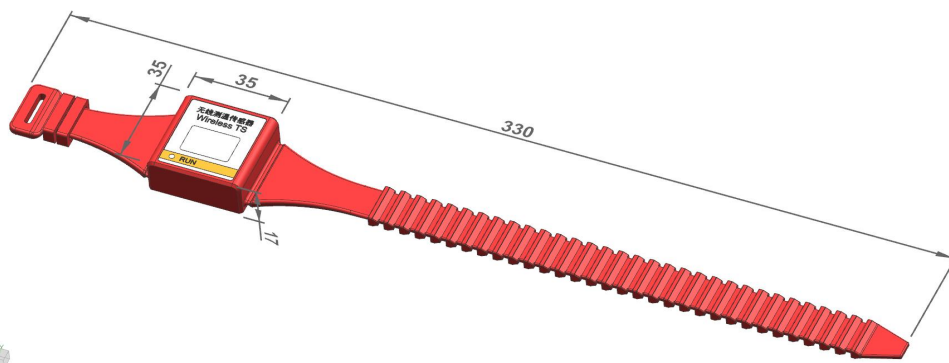

图 1.9 螺栓式无线温度传感器 ATE100

Figure 1.9 Bolt wireless temperature sensor ATE100

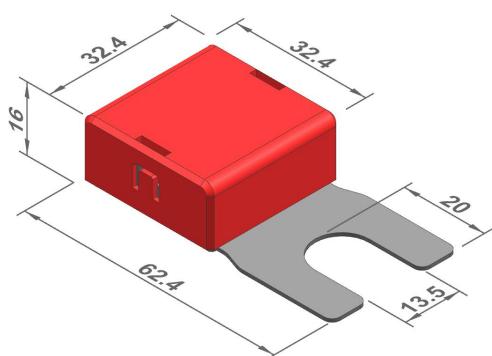

图 1.10 磁吸式无线温度传感器 ATE100M

Figure 1.10 Magnetic wireless temperature sensor ATE100M

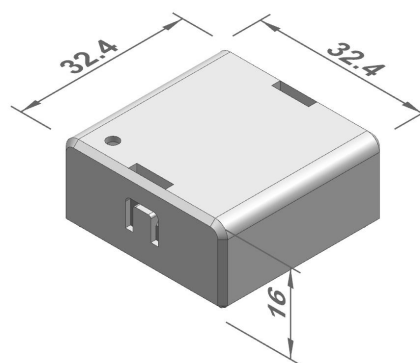

图 1.11 无源无线温度传感器 ATE400

Figure 1.11 Passive wireless temperature sensor ATE400

迷你型无源无线温度传感器结构说明:

Mini type passive temperature sensor structure introduction:

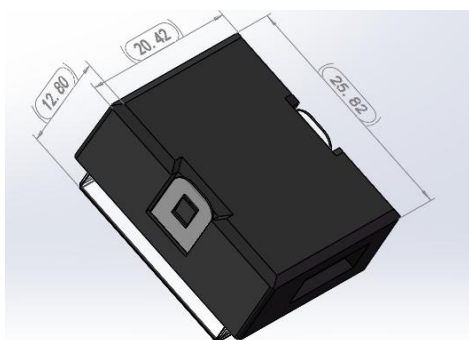
- 1 —— 温度传感器主体 The core of wireless temperature sensor ATE400
- 2 —— 合金底座，与温度探头接触 alloy bottom, touched with temperature probe
- 3 —— 锁扣，用于固定合金片 metal hasp, for fixing alloy chip
- 4 —— 取电合金片，用于感应取电 alloy chip, for CT-powered
- 5 —— 硅胶垫片，用于支撑合金片 silicone gasket, used to support the alloy chip
- 6 —— 合金片安装孔，用于安装合金片 alloy chip hole, used to install the alloy chip



图 1.12 ATE400 结构说明
Figure1.12 structure introduction of ATE400

注意：

1、ATE200/ATE400 可安装静触头，铜排，电缆头；如需安装动触头，需要考虑梅花头及套筒高度是否足够。

2、电池型传感器 ATE100/200 等安装前需要打开电源开关；无源传感器 ATE400 安装时需要保证合金片安装 4 层。详细安装方法可联系我司提供安装指导视频和说明。

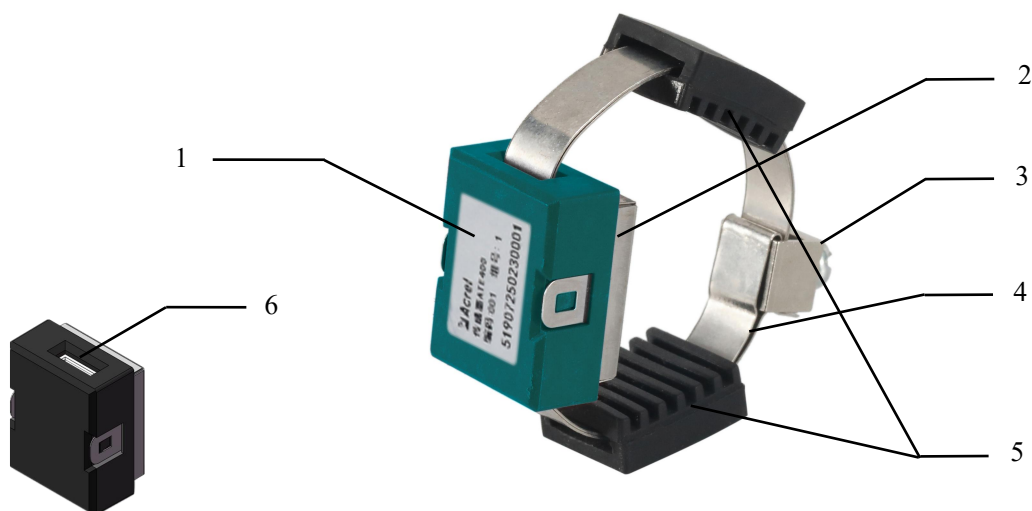
Note:

1.ATE200/ATE400 can be installed with fixed contact, copper plate and cable head; If it is necessary to install moving contacts, it is necessary to consider whether the height of plum blossom head and sleeve is sufficient.

2.Power switch shall be turned on before installation of battery type sensor ate100 / 200; The passive sensor ate400 needs to be installed with 4 layers of alloy sheet. For detailed installation methods, please contact our company to provide installation guidance videos and instructions.

1.6 接线方法

1.6 Wiring method

1.6.1 接线端子

1.6.1 Wiring terminal



图 1.13 ASD100L 背面端子图

Figure 1.13 ASD100L back terminal diagram

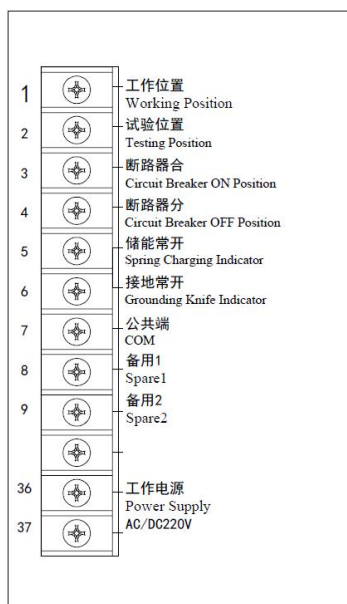

图 1.14 ASD100G 背面端子图

Figure 1.14 ASD100G back terminal diagram



图 1.15 ASD300 背面端子图
Figure 1.15 ASD300 back terminal diagram

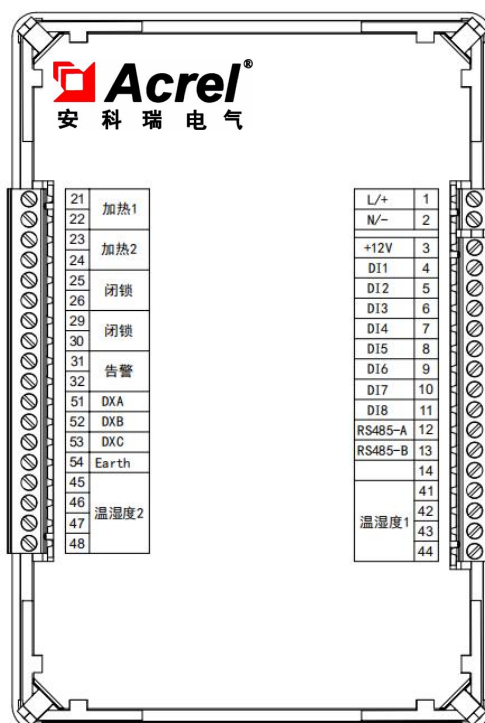

图 1.16 ASD320 背面端子图
Figure 1.16 ASD320 back terminal diagram

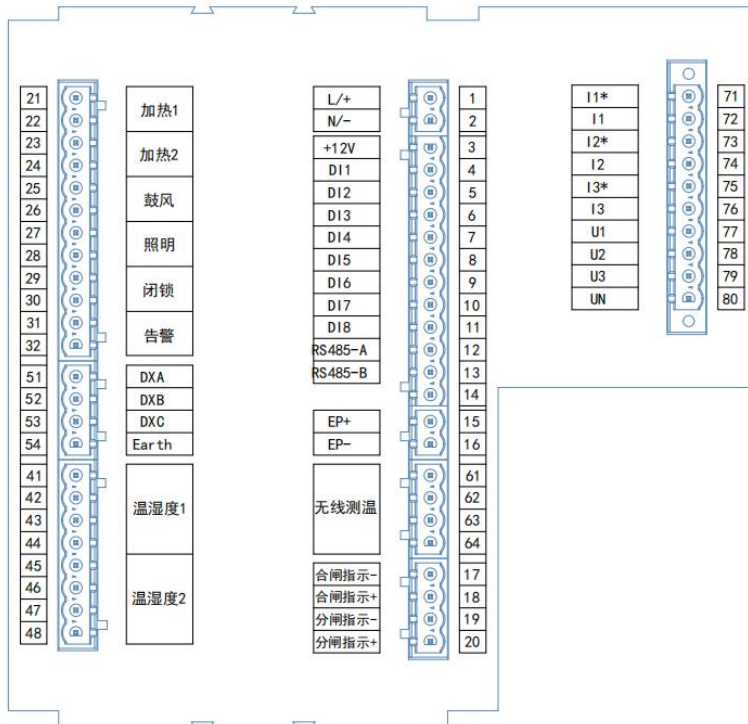

图 1.17 ASD200/310 背面端子图

Figure 1.17 ASD200/310 back terminal diagram

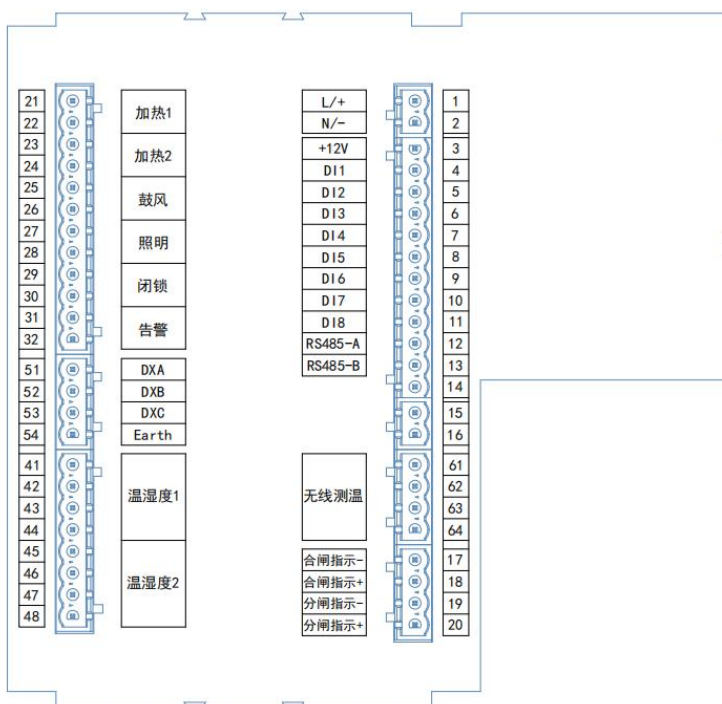
1.6.2 典型接线图

1.6.2 Typical wiring diagram

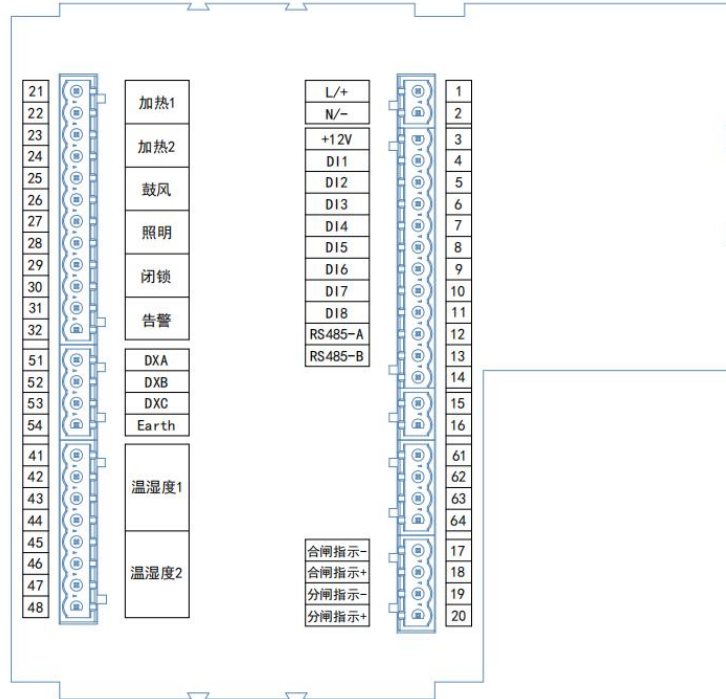

图 1.18 ASD 开关量输入回路典型接线图

Figure 1.18 Typical wiring diagram of ASD switch input circuit

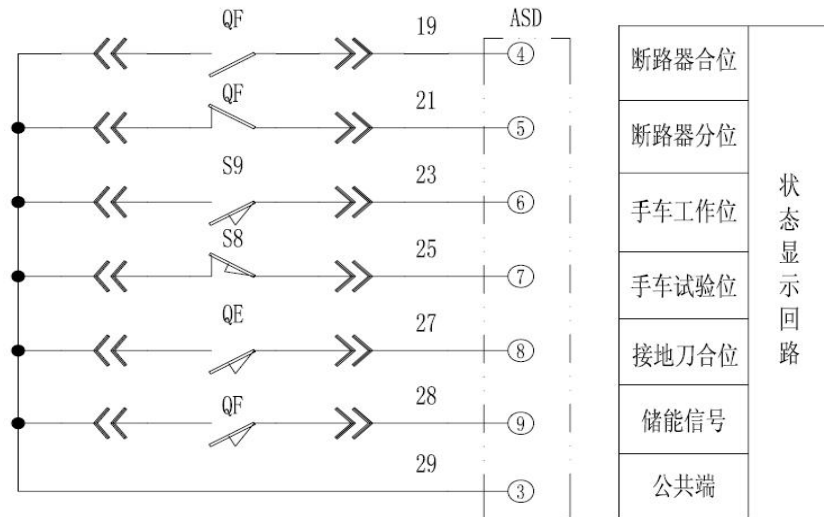

图 1.19 ASD 开关量输出、高压带电显示回路及传感器典型接线图

Figure 1.19 Typical wiring diagram of ASD switch output, HV live displaying circuit and sensor

2 产品操作指南

2 Product operation guide

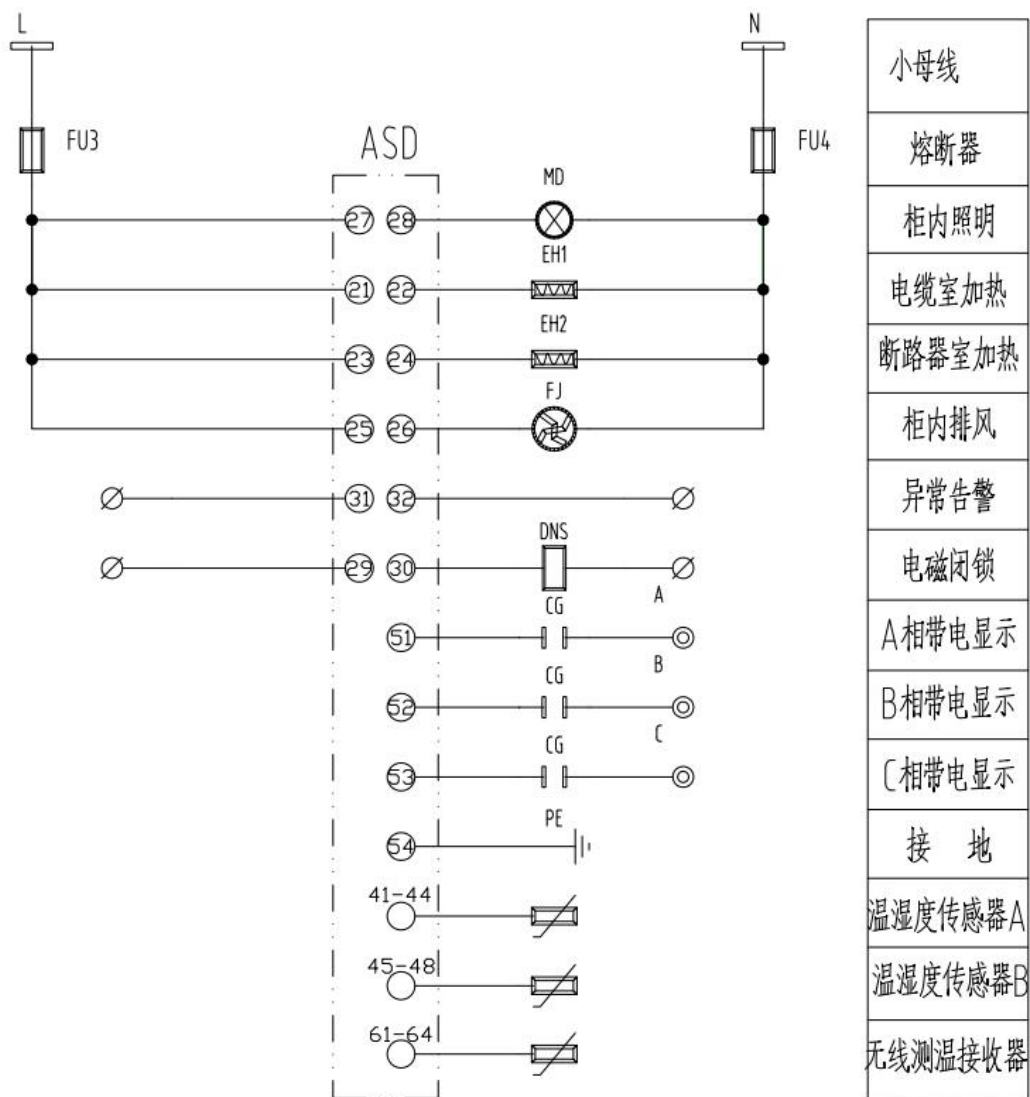
本操作说明主要针对 ASD300 型开关柜综合测控装置，通用功能的描述同样适用于 ASD320、ASD310、ASD200 和 ASD100G 型产品。

The operation instruction mainly aims at ASD300 switch cabinet integrated measuring and control device and the description of general function is also applicable to ASD320, ASD310, ASD200, and ASD100G products.

2.1 显示介绍(ASD300)

2.1 Display introduction (ASD300)



图 2.1 ASD300 前面板图

Figure 2.1 ASD300 front panel diagram

表 3 ASD300 前面板功能说明

Table 3 Function description of ASD300 front panel

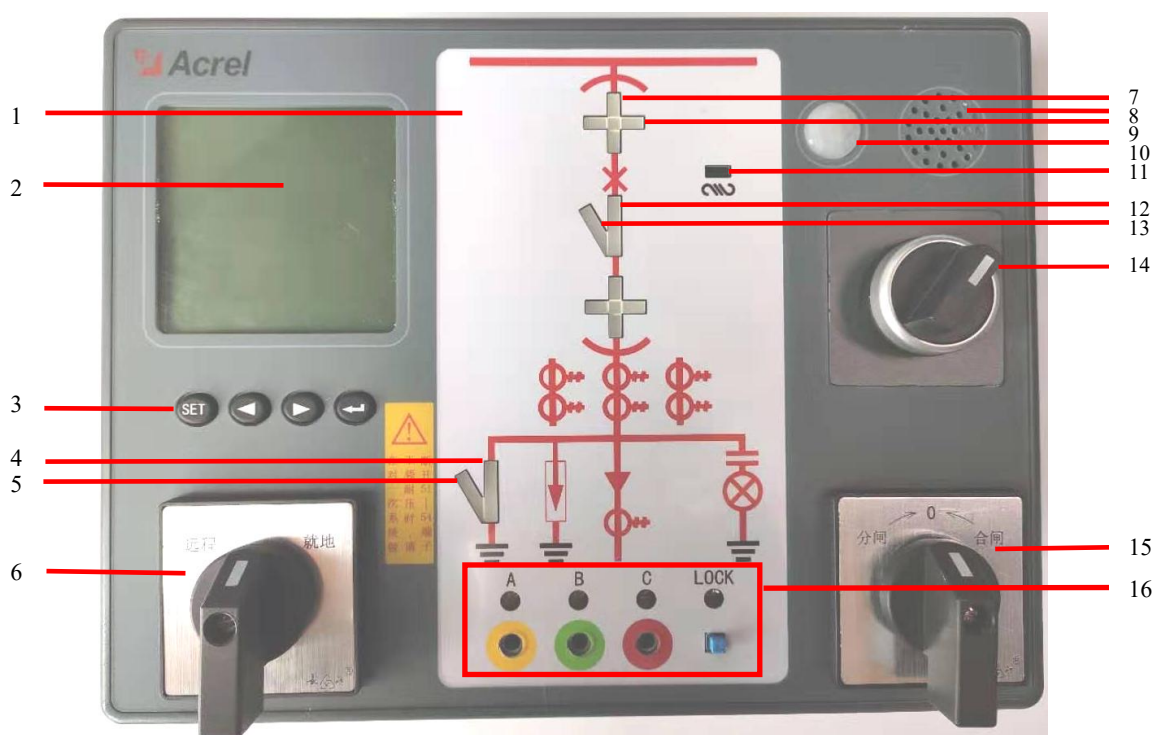
编号 No.	说明 Description	编号 No.	说明 Description
1	一次方案图(电气原理图) Primary scheme diagram (electrical schematic diagram)	9	手车试验位置, 绿色 Testing position of trolley: green

2	液晶显示屏 LCD	10	人体感应探测口 Human body induction detection port
3	按键 Key	11	弹簧储能指示 Spring energy storage instructions
4	接地刀闸合, 红色 Earthing knife-switch closing: red	12	断路器合位置, 红色 Breaker closing position: red
5	接地刀闸分, 绿色 Earthing knife-switch opening: green	13	断路器分位置, 绿色 Breaker tripping position: green
6	远方/就地操作开关 Remote/local operating switch	14	储能旋钮 Stored energy knob
7	手车工作位置, 红色 Operating position of trolley: red	15	分闸/合闸操作开关 Tripping/closing operating switch
8	语音提示 Voice prompt	16	高压带电显示及闭锁 HV live displaying and lock

2.2 操作介绍

2.2 Operation introduction

2.2.1 装置上电

2.2.1 Device power-on

接通符合要求的工作电源，装置即进入工作状态。

Connect the working power supply conforming to requirements and the device will enter working state.

2.2.2 动态模拟图

2.2.2 Dynamic mimetic diagram

1) 断路器分、合闸指示

1) Breaker tripping/closing instructions

将断路器的分、合位置的辅助接点正确接入装置，装置上电正常工作后：

After the auxiliary contact of breaker tripping/closing position is correctly connected to device and the device is powered on for normal operation:

断路器处于合闸状态时，红色发光条 12 亮；

When the breaker is under close position, the red light bar 12 will be on;

断路器处于分闸状态时，绿色发光条 13 亮；

When the breaker is under open position, the green light bar 13 will be on;

2) 手车位置指示

2) Trolley position instructions:

将手车位置的辅助接点正确接入装置，装置上电正常工作后：

After the auxiliary contact of trolley position is correctly connected to device and the device is powered on for normal operation:

手车工作位置接点闭合时，红色发光条 7(上下两条)亮，指示小车位于工作位置；

When the operating position contact of trolley is closed, the red light bar 7 (upper and lower ones) will be on and it indicates that the trolley is under operating position;

手车试验位置接点闭合时，绿色发光条 9(上下两条)亮，指示小车位于试验位置。

When the testing position contact of trolley is closed, the green light bar 9 (upper and lower ones) will be on and it indicates that the trolley is under testing position.

3) 接地开关位置指示

3) Earthing switch position instructions

将接地开关的辅助接点正确接入装置，装置上电正常工作后：

After the auxiliary contact of trolley position is correctly connected to device and the device is powered on for normal operation:

输入接点闭合时，红色发光条 4 亮，表示接地开关处于合闸状态；

When the input contact is closed, the red light bar 4 will be on and it indicates that the earthing switch is under close position;

输入接点断开时，绿色发光条 5 亮，表示接地开关处于分闸状态。

When the input contact is disconnected, the green light bar 5 will be on and it indicates that the earthing switch is under open position.

4) 弹簧储能指示

4) Spring energy storage instructions

将储能机构的辅助接点正确接入装置，装置上电正常工作后，输入接点闭合，指示灯 11 亮，表示已储能。

After the auxiliary contact of energy storage mechanism is correctly connected in the device and the device is powered on for normal operation, the input contact will be closed and the indicator light 11 will be on and it indicates that energy has been stored.

注：开关量与指示灯对应关系可根据用户需求灵活设定！

Note: The correspondence of switch quantity and indicator light can be flexibly set according to user needs.

2.2.3 高压带电显示及闭锁

2.2.3 HV live displaying and lock

装置的高压带电显示功能适用于 3.6-40.5kV/50Hz 系统，与相应电压等级的传感器配合使用，显示主回路的带电情况。若传感器为用户自行配置，须保证其对地短路输出电流大于 200 μ A。

The HV live displaying function of device is applicable to 3.6-40.5kV/50Hz system, which is used

cooperatively with corresponding voltage classes to display the live condition of main circuit. If the sensor is allocated by the user itself, it must guarantee that the earthing short circuit output current shall be larger than $200\mu\text{A}$.

在母线各相电压均小于额定电压的 15% 时，强制闭锁处于“解锁”状态，前面板上“LOCK”指示灯不亮，“闭锁”接点闭合；母线任意相电压大于额定电压的 40% 时，强制闭锁处于“闭锁”状态，“LOCK”指示灯亮，“闭锁”接点断开。

When the voltage of all phases of busbar is less than 15% of rated voltage, the forced lock is under “unlock” status and the “LOCK” indicator light on front panel will not be on and the “Lock” contact will be closed; when any phase voltage of busbar is larger than 40% of rated voltage, the forced lock is under “lock” status and “LOCK” indicator light will be on, the “lock” contact will be disconnected.

2.2.4 报警继电器输出

2.2.4 Alarm relay output

自动定值越限告警继电器输出包括：过压、欠压、过流、温控 1 超温、温控 2 超温、无线温度传感器组 1 高温、无线温度传感器组 2 高温、无线温度传感器组 3 高温、无线温度传感器组 4 高温。

此外，装置失电时告警继电器闭合。

The auto definite value threshold crossing alert relay output includes: overvoltage, undervoltage, over current, temperature control 1 over temperature, temperature control 2 over temperature, wireless temperature sensor group 1 high temperature, wireless temperature sensor group 4 high temperature.

In addition, the alarm relay is closed when the device loses power.

注意：需将相应的控制字选择为“投入”才有效！

Note: It is valid only corresponding control word is selected as “input”.

2.2.5 自动温湿度控制

2.2.5 Auto temperature and humidity control

采用数字式温湿度控制，当环境相对湿度 $\geq 85\%$ ，启动加热，当相对湿度 $\leq 77\%$ ，停止加热；当环境温度 $\geq 40^\circ\text{C}$ ，启动风扇鼓风，当温度 $\leq 35^\circ\text{C}$ ，停止鼓风。当环境温度 $\leq 5^\circ\text{C}$ ，启动加热，当环境温度 $\geq 13^\circ\text{C}$ ，停止加热。ASD100G 无显示，但可自行设定上述参数；ASD200、ASD300、ASD310、ASD320 可测量并采用 LED(ASD200)或 LCD(ASD300、ASD310、ASD320)显示现场环境的温度和湿度，带有加热、鼓风控制接点，可根据需要，自行设定加热、除湿、鼓风的上下限。传感器及其相关的参数及控制接点关系如图 2.2 所示。

Digital temperature and humidity control. When the environment relative humidity is $\geq 85\%$, start heating; when the relative humidity is $\leq 77\%$, stop heating; when the environment temperature is $\geq 40^\circ\text{C}$, start fan blast; when the temperature is $\leq 35^\circ\text{C}$, stop blasting. When the environment temperature is $\leq 5^\circ\text{C}$, start heating; when the environment temperature is $\geq 13^\circ\text{C}$, stop heating. The temperature setting value and the humidity setting value can be set by communication but cannot be displayed in ASD100G; while ASD200、ASD300、ASD310、ASD320 can measure and adopt LED (ASD200) or LCD (ASD300, ASD310,

ASD320) to display the temperature and humidity of site environment. With heating, blast control contact, the upper and lower limit of heating, dehumidification and blast can be set according to requirements. The sensor and related parameters and the relationship between control contact are shown in Figure 2.2.



图 2.2 温湿度控制关系

Figure 2.2 Temperature and humidity control relationship

2.2.6 无线测温（ASD300/ASD320 可选功能）

2.2.6 Wireless temperature measurement (ASD300/ASD320 optional functions)

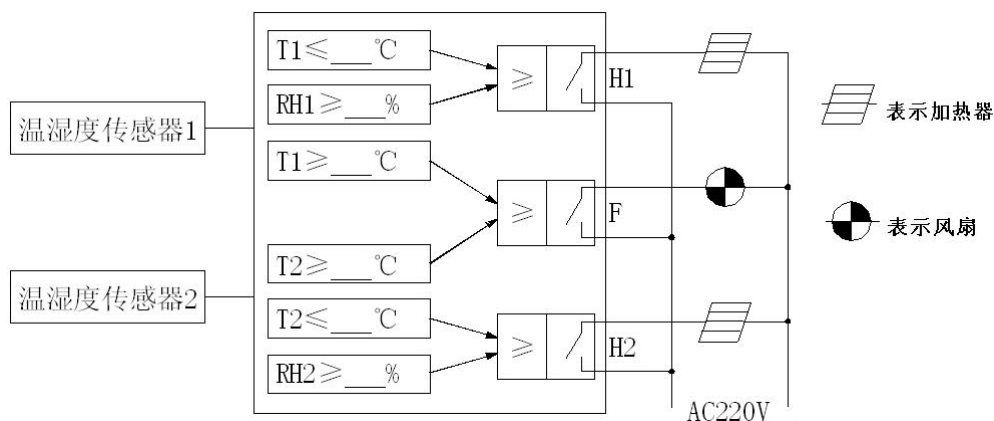
ASD300 和 ASD320 可选无线测温功能，装置通过无线温度接收器和各无线温度传感器直接进行温度值的传输，并采用液晶显示各无线温度传感器所测温度。通过菜单可设置无线温度传感器组的高温告警值，当测得温度值超出设定值时，装置报警继电器输出触点闭合。

ASD300 and ASD320 optional wireless temperature measurement functions. The device can directly transmit temperature values through wireless temperature receiver and all wireless temperature sensors and adopt LCD to display the temperature measured by all wireless temperature sensors. Through menu, the high temperature alarm value of wireless temperature sensor can be set. When the measured temperature value exceeds the set value, the device alarm relay output contact will be closed.

ASD 主体与无线温度传感器的配对及校准（出厂已完成此工作，请勿随意进行此操作）：

Matching and calibration of ASD main body and wireless temperature sensor:(Factory set, Do not change it at will):

1) ASD 主体液晶操作进入“调试—>节温设置”下的节温设置菜单。

1) ASD main body LC operation enters the thermostat setting menu under “debugging --->thermostat .

2) 输入对应无线温度传感器 ID 进行绑定，如查看标签为 A1 的无线温度传感器的 ID，将此 ID 输入到节温 1A，输入完全部要配对传感器，按左键退出保存设置。

2) Enter the ID of the wireless temperature sensor corresponding to the wireless temperature sensor, such as the ID of the wireless temperature sensor with the tag TA1, enter this ID into the section temperature 1A, enter all the sensors to be matched, and press the left button to exit the save setting.

3) ASD 主体液晶操作进入“调试—>节温校准”下的节温校准菜单。

3) ASD main body LC operation enters the thermostat calibration menu under “debugging --->thermostat.

4) 更改需校准的节温值为准确值，按 OK 键进行校准。

4) Change the section temperature to be calibrated to the exact value, press the OK key to calibrate.

警告！ 出厂时包装箱内无线温度传感器与 ASD 主体已配对和校准！安装时不可以与其他 ASD 主体或无线温度传感器混用，无线温度传感器按其标签 A、B、C 分别对应安装到 A、B、C 相。

Warning! When it is delivered, the wireless temperature sensor in the packing case has already been matched with ASD main body and calibrated. When it is installed, it cannot be mixed with any other ASD main body or wireless temperature sensor. The wireless temperature sensor shall be respectively installed to A, B and C-phase according to its label A, B and C.

ASD 主体与无线温度传感器可按以下方法进行配套识别：

The ASD body and the wireless temperature sensor can be identified in the following ways:

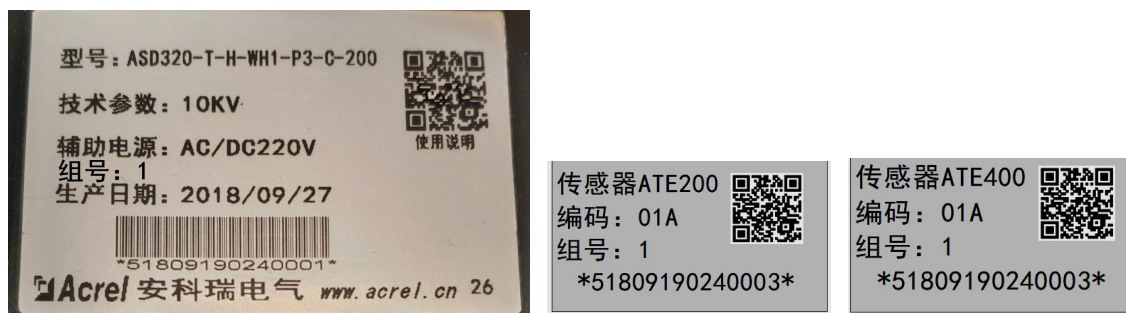

ASD 标签

ATE200 标签

ATE400 标签

ASD Tag

ATE200 Tag

ATE400 Tag

例如左图为一台 ASD 主体的标签，如果此 ASD 配套的传感器为 ATE100/ATE100M/ATE200/ATE400，则传感器和 ASD 主体的“组号”一样。

For example, the left image is a label of an ASD body; if the sensor associated with the ASD is the ATE100/ATE100M/ATE200/ATE400, the "group number" of the sensor and the ASD body is the same.

2.2.7 智能语音防误提示（ASD200、ASD300、ASD310、ASD320）

2.2.7 Intelligent voice error-preventing prompt（ASD200、ASD300、ASD310、ASD320）

智能语音防误提示共有2种方式可选择。

Two methods can be selected for intelligent voice error-preventing prompt.

方式1：断路器、接地开关处于合闸状态，若误将小车从试验位置/ 工作位置推开，装置语音提示“请分断路器，请分接地开关”；断路器处于合闸状态，若误将小车从试验位置/ 工作位置推开，装置语音提示“请分断路器”；接地开关处于合闸状态，若误将小车从试验位置/ 工作位置推开，装置语音提示“请分接地开关”。

Method I: When the breaker and earthing switch are under close position, if the trolley is pushed away from testing position/operating position by mistake, the device will voice prompt “please disconnect the

breaker and earthing switch”; when the breaker is under close position, if the trolley is pushed away from testing position/operating position by mistake, the device will voice prompt “please disconnect the breaker”; when the earthing switch is under close position, if the trolley is pushed away from testing position/operating position by mistake, the device will voice prompt “please disconnect the earthing switch”.

方式2：断路器处于合闸状态，若误将小车从试验位置/工作位置推开，装置语音提示“请分断路器”。

Method II: When the breaker is under close position, if the trolley is pushed away from testing position/operating position by mistake, the device will voice prompt “please disconnect the breaker”.

2.2.8 柜内照明功能（ASD200、ASD300、ASD310、ASD320）





2.2.8 Cabinet lighting function (ASD200, ASD300, ASD310, ASD320)

在装置默认主界面下，长按右键，将打开柜内照明；再次长按右键，将关闭柜内照明。

Press the Up key under the default main interface of device to open the lighting in the cabinet; then press the Up key again to close the lighting in the cabinet.

表 4 按键功能说明

Table 4 Function description of key

按键 Key	说明 Description
	用于参数设置退出及返回上一级菜单功能 used for parameter setting exit and return to the previous menu function
	在测量模式下，用于切换显示项目，在编程模式下，用于切换同级菜单 in the measurement mode, it is used to switch the display items, and in the programming mode, it is used to switch the menu at the same level.
	在测量模式下，用于切换显示项目；在编程模式下，用于切换同级菜单或参数某位数的增加。 in the measurement mode, it is used to switch the display items; in the programming mode, it is used to switch the menu of the same level or the increase of a certain number of parameters.
	用于菜单项目的选择确认和参数的修改确认。 for selection confirmation of menu items and confirmation of modification of parameters.

2.2.9 人体感应(ASD200、ASD300、ASD310、ASD320)

2.2.9 Human body induction (ASD200, ASD300, ASD310, ASD320)

LCD 背光自动控制开启（背光延时设置不为 0），人离开装置一段时间后，自动关闭柜内照明和液晶背光；当有人接近装置时，装置通过感应到周围红外场的变化感知有人接近，自动打开柜内照明及液晶背光。

LCD backlight auto control open (backlight delay shall not be set as 0): after leaving the device for a

while, it will automatically close the lighting and LC backlight in the cabinet; when someone approaches the device, the device will perceive that someone is approaching through the change of surrounding infra-red field and automatically open the lighting and LC backlight in the cabinet.

2.2.10 电力参数测量(ASD300)

2.2.10 Electric power parameter measurement (ASD300)

ASD300 型开关柜综合测控装置可以测量主回路的电流、电压、有功功率、功率因数、电能等电力参数，可在装置“电量”菜单中查看，通过左/右键切换显示内容，无功功率、视在功率等可以通过通讯口读出。

ASD300 switch cabinet integrated measuring and control device can measure the current, voltage, active power, power factor, electric energy and other electric parameters of main circuit and check in the “electric quantity” menu of device. By left/right key switch display content, the active power, apparent power can be read out through communication port.

电参数的显示均为一次侧值，用户需选择正确的信号接入方式及 CT、PT 变比，以便正确显示测量值。

The display of electric parameter is all primary side value and the user shall select correct signal access way and CT, PT no-load voltage ratio to correctly display the measured value.

2.2.11 带电显示自检 (ASD100G、ASD200、ASD300、ASD310、ASD320)

2.2.11 Self-inspection of live displaying (ASD100G, ASD200, ASD300, ASD310, ASD320)

ASD 系列开关柜综合测控装置具有带电显示自检功能，可在装置面板的下方按键进行自检操作。按下按钮，对应指示灯亮并保持几秒钟，闭锁继电器端子断开（闭锁继电器端子不工作时处于常闭状态），说明带电显示灯正常。

ASD series switch cabinet integrated measuring and control device has live displaying self-inspection function, which can take self-inspection operation through the key under device panel. Press the button and corresponding LED will be lit for a few seconds and the lock relay will be open (it is normally closed when lock relay terminal is not working) and it indicates that the live displaying light is normal.

2.2.12 核相功能 (ASD100G、ASD200、ASD300、ASD310、ASD320)

2.2.12 Nuclear phase function (ASD100G, ASD200, ASD300, ASD310, ASD320)

ASD 系列开关柜综合测控装置具有带电显示核相功能，在装置接入高压信号经带电显示传感器后的信号后，可通过外接核相器接入装置的核相孔中，进行核相操作。该核相功能适用于市面上大多数的核相器（门槛电压 $\geq 60V$ ）。

ASD series switch cabinet integrated measuring and control device has live displaying nuclear phase function. After connecting the signal of live displaying sensor through HV signal, it can take nuclear phase operation by connecting the nuclear phase into the nuclear phase hole of device. This nuclear phase function is applicable to great majority nuclear phase testers in the market (with threshold voltage $\geq 60V$).

注：本公司不配置核相器。

Note: Nuclear phase tester is not configured in our company.

2.3 ASD300 编程设置

2.3 ASD300 programming setting

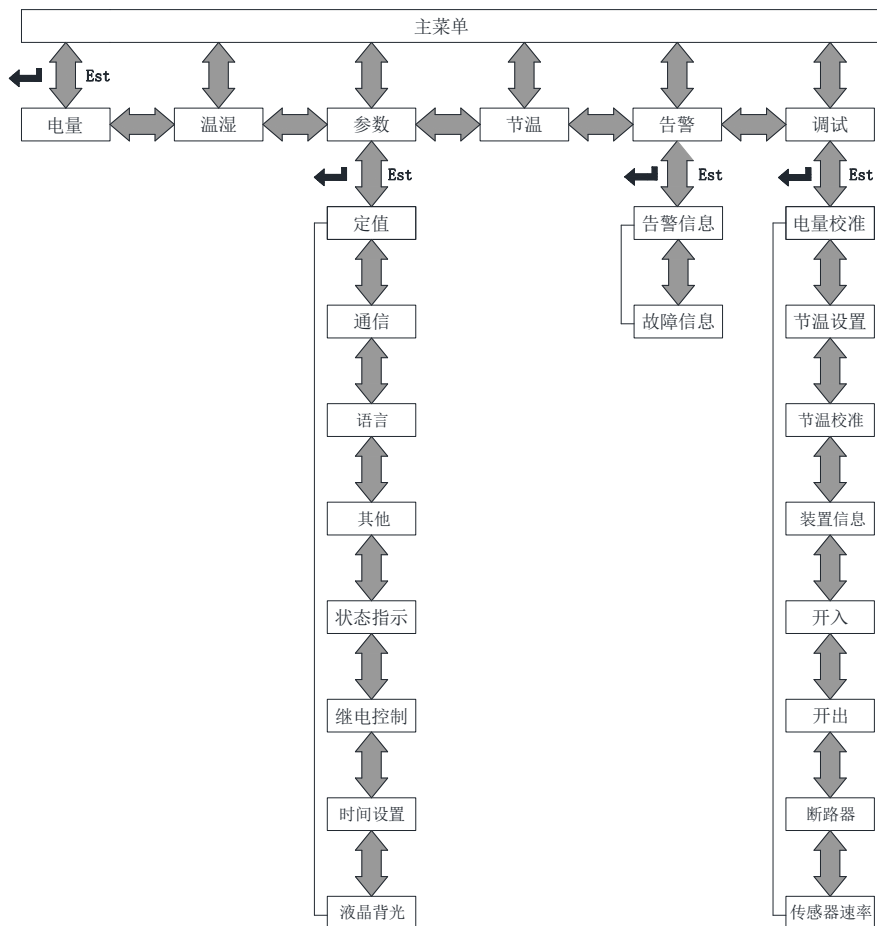



图 2.3 ASD300 菜单结构

Figure 2.3 ASD300 menu structure

- 1) 上电后，装置自检，若自检通过，则进入电力参数显示界面，通过左键（或右键）切换查看电流、电压、功率、电能等各类电力参数（均为一次侧值）。
- 1) After power on, take self-inspection to the device. If the self-inspection passes, enter electric parameter display interface and check the current, voltage, power, electric energy and various kinds of electric parameters (all primary side values) through left key (or right key) switching.
- 2) 测量参数显示界面下，按 SET 键，装置进入主菜单页面，该页面下，每一个子菜单项都由图标和相应的文字组成，两个方向键选择（被选中的菜单为反显状态）所需菜单项，然后按回车键进入相应的子菜单。
- 2) Press OK key under measurement parameter display interface and the device will enter the main menu page. Under this page, every submenu is composed of icon and corresponding characters. Four direction keys can be used to select (the selected menu is reverse display status) the required menu item and then press OK key to enter corresponding submenu.
- 3) 主菜单页面下，选择并确认“电量”菜单，可返回到电量参数显示界面。
- 3) Under main menu page, select and confirm “Electric quantity” menu to return the electric quantity parameter display interface.

- 4) 主菜单页面下，选择并确认“温湿”菜单，即进入温湿度控制信息显示页面，如下图所示。该页面左右二侧分别显示通道 1 和通道 2 所测得的环境温度和湿度。
- 4) Under main menu page, select and confirm “temperature and humidity” menu to enter the temperature and humidity control information display interface, as shown in the figure below. The left and right side of the page respectively display the environment temperature and humidity measured through channel 1 and channel 2.
- 5) “参数”菜单可以设置装置工作的各类参数，包括电流电压信号的输入方式、变比，各类报警阈值、控制字，通讯参数等。该菜单下的内容需要用户口令才可以查看或修改，出厂设置口令为“0008”。
- 5) “Parameter” menu can set various kinds of operating parameters of device, including the input mode, no-load voltage ratio of current and voltage signal, various kinds of alarm threshold value, control word, communication parameters, etc. The content under the menu can be checked or modified only by user password. The factory set password is “0008”.

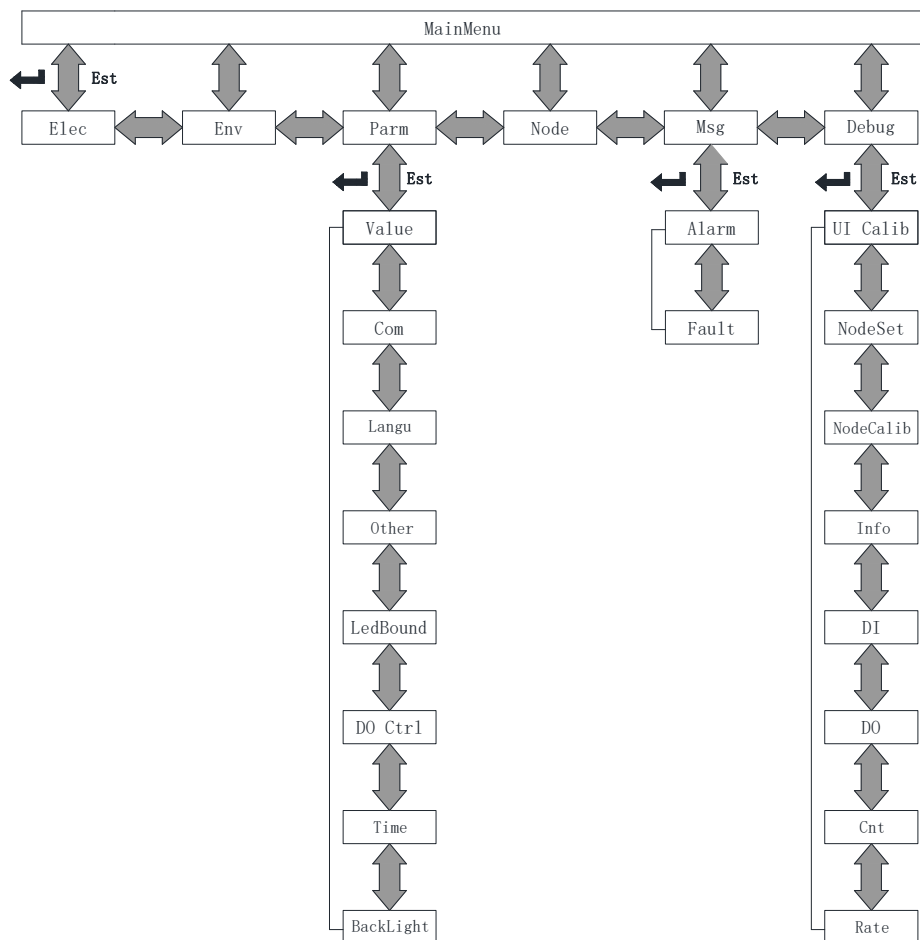
参数修改方法：进入子菜单，通过左右键先选中要设置项的名称，然后按回车键等光标定位到对应的值时，按右键修改值，再按回车键确认（光标会定位到项目名称上），最后按 SET 键退出时，界面会提示是否保存修改过的参数，按右键选择“**Yes**”后再按回车键保存即可。

Parameter modification method: enter the submenu and select the name of setting items through left and right key and then press enter key and other cursors to position to corresponding values. Press the right key to modify the value and then press enter key to confirm (the cursor will position to project name). Lastly, when pressing “SET” key to exit, the interface will prompt whether to save the modified parameters and then press right key to select "Yes" and press enter key to save.

“定值”子菜单下可设置如电流电压接线方式，变比报警阈值等（电参数告警定值均采用二次侧值）。例如，过压投退设置为“投入”，则当装置测得的电压值高于过压定值时，报警继电器输出触点闭合。

The current and voltage wiring mode and no-load voltage ratio alarm threshold value (electric parameter alarm definite values all adopt secondary side value) can be set under “definite value” submenu. For example, set the overvoltage in-service and out-of-service as “in-service”, when the measured voltage value of device is higher than the overvoltage definite value, the alarm rely output contact will be closed.

“状态指示”子菜单下可设置 LED 灯与开入的对应关系，也可设置 LED 灯常亮（ON）或者是常灭（OFF）。

The correspondence of LED lamp and opening-in can be set under “status indicator” submenu and LED lamp can be set as normally on (ON) or normally off (OFF).

“通信”子菜单下可设置设备的通讯地址及串口波特率。

The communication address and series rate can be set under “communication” submenu.

“继电控制”子菜单下可设置开出模式，模式分为：

Opening-out mode can be set under “relay control” submenu and the mode is classified into:

ON: 设备上电后，继电器常闭触点为断开，常开触点为闭合（适用于手动控制）。

ON: After the device is powered on, the relay normally-closed contact will be disconnected and the normally-open contact will be closed (applicable to manual control).

OFF: 设备上电后，继电器常闭触点为闭合，常开触点为断开（适用于手动控制）。

OFF: After the device is powered on, the relay normally-closed contact will be closed and the normally-open contact will be disconnected (applicable to manual control).

Def.: 由内部逻辑控制继电器的闭合或断开。

Def: The interior logic will control the relay opening or closing.

“其它”子菜单下可进行“清电能”，“次数清零”和“恢复出厂”操作，出厂设置口令为“1008”。

“Clearing electric energy”, “Time reset” and “factory reset” operation can be taken under “others” submenu and the factory setting password is “1008”.

注意:

Note:

1、恢复出厂后，除电参量校准数据，无线温度配对和校准数据外，其他所有参数都将恢复为出厂默认设置。恢复出厂后设备须重新上电后才生效！

1. After factory reset, except electric parameter calibration data, wireless temperature matching and calibration data, all the other parameters will be reset as factory default. After factory reset, the equipment must be powered on before it is effective.

2、电能清零后无法恢复，请谨慎使用此功能！

2. The electric energy will not be recovered after resetting, please be cautious to use this function!

“液晶背光”子菜单下可设置液晶背光点亮时长。

LC backlight lightening length can be set under “LC backlight” submenu.

注意: 对有人体感应的装置，该时间值也是人体感应控制照明输出的时间。

Note: For device with human body induction, the time value is also the time that human body induction controls lighting output.



图 2.4 接线方式

Figure 2.4 Wiring mode

- 6) 主菜单页面下，选择并确认“节温”菜单，即进入无线温度测量显示界面。
- 6) Under main menu page, select and confirm “thermostat” menu to enter the wireless temperature measurement display interface.
- 7) 主菜单页面下，选择并确认“告警”菜单，即进入告警信息显示界面。
- 7) Under main menu page, select and confirm “alarm” menu to enter alarm information display interface.
- 8) 主菜单页面下，选择并确认“调试”菜单，可校准电参量，绑定无线温度传感器，查看开入开出，断路器分合次数统计及其版本信息。
- 8) Under main menu page, select and confirm “debugging” menu to calibrate the electric parameter, bind wireless temperature sensor and check the switch in-out, breaker on-off time statistics and version information.

2.4 ASD200 编程设置

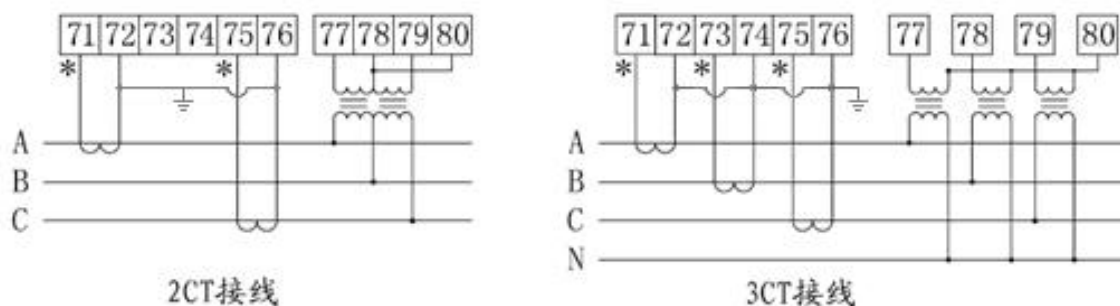
2.4 ASD200 programming setting



图 2.5 ASD200 菜单结构

Figure 2.5 ASD200 menu structure

表 5 ASD200 菜单功能

Table 5 ASD200 menu function

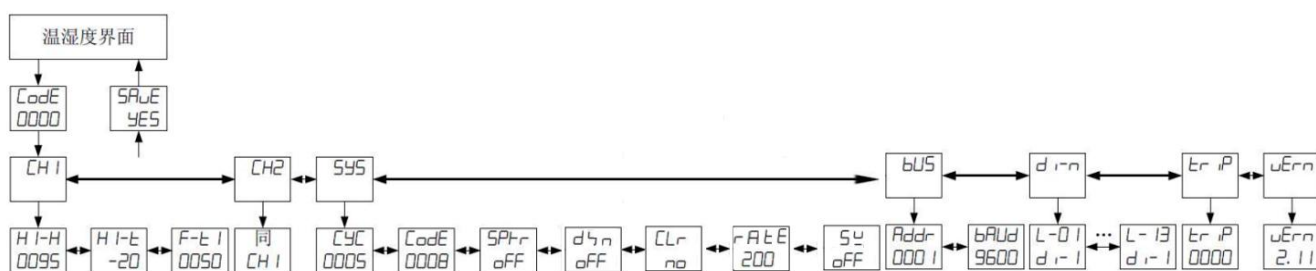
图例 Legend	说明 Description	图例 Legend	说明 Description
<i>Code</i>	密码/设置新密码 Password/set new password	<i>bUS</i>	通讯总线参数 Communication bus parameter
<i>CH1</i>	温湿度通道 1 Temperature and humidity channel 1	<i>Addr</i>	本机地址 Local address
<i>HI-H</i>	加热 1，湿度启动定值 Heating 1, definite value for humidity starting	<i>bAUD</i>	波特率 Baud rate
<i>HI-L</i>	加热 1，温度启动定值	<i>d1-n</i>	开入配置

	Heating 1, definite value for temperature starting		Opening-in configuration
<i>F-t 1</i>	鼓风, 温度 1 启动定值 Blast, definite value for temperature 1	<i>L-0 1</i>	待配灯号 (1~25) Lamp signal to be configured (1-25)
<i>CH2</i>	温湿度通道 2 Temperature and humidity channel 2	<i>d 1- 1</i>	可配开入号 (1~8) Configurable opening-in number (1-8)
<i>SYS</i>	系统设置 System setting	<i>on</i>	常开 Normally open
<i>CYC</i>	循环显示切换时间 Circulation display switching time	<i>off</i>	常闭 Normally closed
<i>SPT-r</i>	语音防误类型设置 Voice error-preventing type setting	<i>tr ip</i>	断路器分合次数 Break on-off times
<i>CLR</i>	断路器分合次数清零 Breaker on-off time resetting	<i>uErn</i>	软件版本 Software version
<i>d 4n</i>	带电语音提示 Voice prompts	<i>rAtE</i>	内部参数 Internal parameter
<i>SU</i>	分合闸电压监测 tripping circuit and closing circuit voltage measurement		

3 通讯指南

3 Communication guide

在本章主要讲述如何利用软件通过通讯口来操控该系列仪表。本章内容的掌握需要您具有 MODBUS 协议的知识储备并且通读了本册其他章节所有内容，对本产品功能和应用概念有较全面的了解。

In this chapter, it mainly introduces how to use software to control this series of instrument through communication port. To master this chapter, you must possess the knowledge reserve of MODBUS and have read all the contents in other chapters and have comprehensive understanding to the function and application concept of the product.

本章内容包括：通讯应用格式详解，本机的应用细节及参量地址表。

The content of the chapter includes: detailed explanation of communication application format, application details and parameter address table.

3.1 通讯格式详解

3.1 Detailed explanation of communication format

本节所举实例将尽可能的使用如下表所示的格式，数据为十六进制。

The format shown in table below will be used as much as possible for the examples in this section and the data is hexadecimal.

3.1.1 读取数据（功能码 03H/04H）

3.1.1 Reading data (function code 03H/04H)

此功能允许用户获得设备采集与记录的数据及系统参数。主机一次请求的数据个数没有限制，但不能超出定义的地址范围。

The function allows user to obtain the data and system parameters collected and recorded by equipment. There is no restriction to the data number primarily requested by main engine, but it shall not exceed the defined address scope.

例如，主机发送查询数据帧：

For example, main engine will send the query data frame:

地址 Addr	功能码 Fun	起始地址 Start Addr		寄存器数量 Register number		CRC16 校验码 CRC 16 check code	
		高 High	低 Low	高 High	低 Low	高 High	低 Low
01H	03H	00H	30H	00H	03H	05H	C4H

装置返回响应数据帧：

The device will return the response data frame:

地址 Addr	功能码 Fun	字节数 byte	数据 1 Date 1		数据 2 Date 2		数据 3 Date 3		CRC16 校验码 CRC 16 check code	
			高 High	低 Low	高 High	低 Low	高 High	低 Low	高 High	低 Low
01H	03H	06H	00H	00H	00H	00H	00H	00H	21H	75H

3.1.2 预置单个寄存器（功能码 06H）

3.1.2 Preset single register (function code 06H)

此功能码允许用户改变单个寄存器的内容，可通过此功能码将工作参数写入装置。

The function code allows user to change the content of single register and operating parameters can be written into device through the function code.

例如，主机发送：

For example, the main engine sends:

地址 Addr	功能码 Fun	寄存器地址		预置值		CRC16 校验码	
		Register address		Preset value		CRC 16 check code	
		高 High	低 Low	高 High	低 Low	高 High	低 Low
01H	06H	00H	03H	03H	E8H	74H	79H

装置返回响应数据帧：

The device returns to response data frame:

地址 Addr	功能码 Fun	寄存器地址		预置值		CRC16 校验码	
		Register address		Preset value		CRC 16 check code	
		高 High	低 Low	高 High	低 Low	高 High	低 Low
01H	06H	00H	03H	03H	E8H	74H	79H

3.1.3 预置多个寄存器（功能码 10H）

3.1.3 Preset several registers (function code 10H)

此功能码允许用户改变多个寄存器的内容，可通过此功能码将工作参数写入装置。

The function code allows user to change the content of several registers and operating parameters can be written into device through the function code.

例如，主机发送：

For example, the main engine sends:

地址 Addr	功能码 Fun	起始地址		寄存器数		字节数 byte	预置值 1		预置值 2		CRC16	
		Start Addr		Register number			Preset value 1		Preset value 1		CRC 16 check code	
		高 High	低 Low	高 High	低 Low		高 High	低 Low	高 High	低 Low	高 High	低 Low
01H	10H	00H	03H	00H	02H	04H	00H	28H	00H	64H	59H	32H

装置返回响应数据帧：

The device returns to response data frame:

地址 Addr	功能码 Fun	起始地址		寄存器数量		CRC16 校验码	
		Start Addr		Register number		CRC 16 check code	
		高字节 High byte	低字节 Low byte	高字节 High byte	低字节 Low byte	高字节 High byte	低字节 Low byte
01H	10H	00H	03H	00H	02H	B1H	C8H

3.2 参量地址表

3.2 Parameter address table

地址 Addr	参数 Parameter	属性 Read/ Write	数值范围 Data range	数据类型 Data Type
------------	-----------------	----------------------	--------------------	-------------------

0000H	通讯地址 Communication Addr	R/W	1-247	Word
0001H	通讯波特率 Communication Baud rate	R/W	2400、4800、9600、19200	Word
0002H	电量输入方式 Electric parameter Input mode	R/W	0: 3P3L 1:3P4L	Word
0003H	电流变比 CT transformation	R/W	0.1~999.9 (x10)	Word
0004H	电压变比 PT transformation ratio	R/W	0.1~999.9 (x10)	Word
0005H	控制字 Control word	R/W	继电器报警控制字: 0-off 1-on bit0:过压 bit1:欠压 bit2:过载 bit3-温湿控 1 bit4-温湿控 2 bit5:语音提示 bit8~bit11 节温组 1~4 bit12:分合闸电压检测开启 Alarm relay control word:0-off, 1-on bit0:Over voltage; bit1:under voltage; bit2:over load; bit3-Temp./humidity control 1; bit4-Temp./humidity control 2; bit5:Voice alert; bit8~bit11: The section temperature group 1to4; bit12: tripping circuit and closing circuit control voltage measurement function enabled.	Word
0006H	通道 A 低温设定值 (加热 I) Channel A Lo.temp.setting (heating I)	R/W	-45~125℃	Word
0007H	通道 A 高温设定值 (鼓风) Channel A Hi.temp.setting(air blowing)	R/W	0~125℃	Word
0008H	通道 A 超温设定值 (告警) Channel A over-temp setting(alarm)	R/W	0~125℃	Word
0009H	通道 A 高湿度设定值 (加热 I) Channel A Hi	R/W	10~99%	Word

	humidity setting(heating I)			
000AH	通道 B 低温设定值 (加热 II) Channel B Lo.temp. setting(heating II)	R/W	-45~125℃	Word
000BH	通道 B 高温设定值 (鼓风) Channel B Hi.temp.setting(air blowing)	R/W	0~125℃	Word
000CH	通道 B 超温设定值 (告警) Channel B over-temp setting(alarm)	R/W	0~125℃	Word
000DH	通道 B 高温设定值 (加热 II) Channel B Hi.temp.setting (heating II)	R/W	10~99%	Word
000EH	过压定值 Overvoltage setting	R/W	二次侧 1~999V Secondary side 1~999V	Word
000FH	欠压定值 Undervoltage setting	R/W	二次侧 1~999V Secondary side 1~999V	Word
0010H	过流定值 Overcurrent setting	R/W	二次侧 0~99.9A (x10) Secondary side 0~99.9A (x10)	Word
0011H	液晶背光自动关闭 时间 Liquid crystal back light Automatic closed time	R/W	0-999s, 0—背光常亮 0-999s, 0: Always bright backlight	Word
0012H	继电器输出 Relay output	R/W	bit0-4 对应: 加热 I、加热 II、鼓风、告警、照明 Bit0-bit4: Heating I,heating II,air blowing,alarming,lighting	Word
0013H	开关量输入 Switching input	R	Bit0-bit7 对应 DI1-DI8 Bit0-bit7 corresponding DI1-DI8	Word
0014H	定值类报警状态 Value class alarm status	R	0-未告警 1-告警 bit0-bit3 对应: 通道 A 低温、通道 A 高温、 通道 A 超温、通道 A 高湿 bit4-bit7 对应: 通道 B 低温、通道 B 高温、 通道 B 超温、通道 B 高湿 bit8:过压 bit9:欠压 bit10:过载 bit11-bit12 对应: 第一路测温故障、第二路	Word

			测温故障 bit13-bit14 对应：第一路加热器故障 第二路 加热器故障 0-no alarm,1-alarmed. Bit0-bit3 corresponding: Channel A Lo.temp,Channel A Hi.temp,Channel A over temp,Channel A Hi humidity Bit4-bit7 corresponding: Channel B Lo.temp,Channel B Hi.temp,Channel B over temp,Channel B Hi humidity Bit8:over voltage;Bit9:under voltage; Bit10:over load Bit11-bit12 corresponding: 1nd temperature sensor failure, 2nd temperature sensor failure Bit13-bit14 corresponding: 1nd heating circuit fault alarm, 2nd heating circuitfault alarm	
0015H	无线温度传感器高 温报警状态 Wirless temperature sensor Hi.temp. alarm status	R	0: 未报警 1: 已报警 bit0~bit11:节点 1A~4C 高温 0-no alarm,1-alarmed. Bit0-bit 11 : Section temperature 1A~ Section temperature 4C sensor Hi.temp.	Word
0016H	无线温度传感器低 电压报警状态 Wirless temperature sensor low voltage alarm status	R	0: 未报警 1: 已报警 bit0~bit11:节点 1A~4C 传感器低电压 0-no alarm,1-alarmed. Bit0-bit 11 : Section temperature 1A~ Section temperature 4C sensor low voltage.	Word
0017H	语音防误提示方式 Wrong voice prompts	R/W	1~2	Word
0018H	年份 Year	R/W	10~99 (对应 2010~2099) 10~99 corresponding: 2010~2099	Word
0019H	月份 Month	R/W	1~12	Word
001AH	高位: 日 High: Day	R/W	1~31	Word
	低位: 时 Low: Hour	R/W	0~23	Word
001BH	高位: 分 High: Minute	R/W	0~59	Word
	低位: 秒 Low: Second	R/W	0~59	Word
001CH	无线温度传感器组 1 高温定值	R/W	0~125℃	Word

	Wireless temperature sensor group 1 high temperature setting			
001DH	无线温度传感器组 2 高温定值 Wireless temperature sensor group 2 high temperature setting	R/W	0~125℃	Word
001EH	无线温度传感器组 3 高温定值 Wireless temperature sensor group 3 high temperature setting	R/W	0~125℃	Word
001FH	无线温度传感器组 4 高温定值 Wireless temperature sensor group 4 high temperature setting	R/W	0~125℃	Word
0020~0022H	1A 1B 1C 温度值 1A 1B 1C temperature value	R	0~125.0℃ (x10)	Word
0023~0025H	2A 2B 2C 温度值 2A 2B 2C temperature value	R	0~125.0℃ (x10)	Word
0026~0028H	3A 3B 3C 温度值 3A 3B 3C temperature value	R	0~125.0℃ (x10)	Word
0029~002BH	4A 4B 4C 温度值 4A 4B 4C temperature value	R	0~125.0℃ (x10)	Word
002CH	通道 A 温度值 Channel A temperature value	R	-45.0~125.0℃ (x10)	Word
002DH	通道 A 湿度值 Channel A humidity value	R	10.0~99.0% (x10)	Word
002EH	通道 B 温度值 Channel B temperature value	R	-45.0~125.0℃ (x10)	Word
002FH	通道 B 湿度值 Channel B humidity value	R	10.0~99.0% (x10)	Word
0030H	相电压 UA	R	一次侧: 0~6553.5 kV (x10)	Word

	Phase voltage UA		Primary side: 0~6553.5 kV (x10)	
0031H	相电压 UB Phase voltage UB	R	一次侧: 0~6553.5 kV (x10) Primary side: 0~6553.5 kV (x10)	Word
0032H	相电压 UC Phase voltage UC	R	一次侧: 0~6553.5 kV (x10) Primary side:	Word
0033H	线电压 UAB Line voltage UAB	R	一次侧: 0~6553.5 kV (x10) Primary side: 0~6553.5 kV (x10)	Word
0034H	线电压 UBC Line voltage UBC	R	一次侧: 0~6553.5 kV (x10) Primary side: 0~6553.5 kV (x10)	Word
0035H	线电压 UAC Line voltage UAC	R	一次侧: 0~6553.5 kV (x10) Primary side: 0~6553.5 kV (x10)	Word
0036H	IA	R	一次侧: 0~6553.5 A (x10) Primary side: 0~6553.5 kV (x10)	Word
0037H	IB	R	一次侧: 0~6553.5 A (x10) Primary side: 0~6553.5 kV (x10)	Word
0038H	IC	R	一次侧: 0~6553.5 A (x10) Primary side: 0~6553.5 kV (x10)	Word
0039H	保留 Reserved	R	保留 Reserved	
003AH-003B H	PA	R	一次侧: 0~6553.5kW Primary side: 0~6553.5kW	float
003CH-003D H	PB	R	一次侧: 0~6553.5kW Primary side: 0~6553.5kW	float
003EH-003F H	PC	R	一次侧: 0~6553.5kW Primary side: 0~6553.5kW	float
0040H-0041 H	Psum	R	一次侧: 0~6553.5kW Primary side: 0~6553.5kW	float
0042H-0043 H	QA	R	一次侧: 0~6553.5kvar Primary side: 0~6553.5kvar	float
0044H-0045 H	QB	R	一次侧: 0~6553.5kvar Primary side: 0~6553.5kvar	float
0046H-0047 H	QC	R	一次侧: 0~6553.5kvar Primary side: 0~6553.5kvar	float
0048H-0049 H	Qsum	R	一次侧: 0~6553.5kvar Primary side: 0~6553.5kvar	float
004AH-004B H	PFA	R	0.0~1.0	float
004CH-004D H	PFB	R	0.0~1.0	float
004EH-004F H	PFC	R	0.0~1.0	float
0050H-0051 H	Pfsum	R	0.0~1.0	float

0052H-0053 H	SA	R	一次侧: 0~6553.5kVA Primary side: 0~6553.5kVA	float
0054H-0055 H	SB	R	一次侧: 0~6553.5kVA Primary side: 0~6553.5kVA	float
0056H-0057 H	SC	R	一次侧: 0~6553.5kVA Primary side: 0~6553.5kVA	float
0058H-0059 H	Ssum	R	一次侧: 0~6553.5kVA Primary side: 0~6553.5kVA	float
005AH-005B H	Freq	R	45.0~65.0Hz	float
005CH-005D H	电能 Electrical energy	R	一次侧: 0.0~99999999.99kWh Primary side: 0.0~99999999.99kWh	float
005EH	产品类型 Product Type	R/W	0~5 对应: 100、100G、200、300、310、320	Word
005FH	通道A 低温报警返回 值设定 Low temperature alarm return value of Channel A	R/W	-45~125℃	Word
0060H	通道A 高温报警返回 值设定 High temperature alarm return value of Channel A	R/W	0~125℃	Word
0061H	通道A 超温报警返回 值设定 Over temperature alarm return value of Channel A	R/W	0~125℃	Word
0062H	通道A 高湿报警返回 值设定 High humidity alarm return value of Channel A	R/W	10~99%	Word
0063H	通道B 低温报警返回 值设定 Low temperature alarm return value of Channel B	R/W	-45~125℃	Word
0064H	通道B 高温报警返回 值设定 High temperature alarm return value of Channel B	R/W	0~125℃	Word

0065H	通道B超温报警返回值设定 Over temperature alarm return value of Channel B	R/W	0~125℃	Word
0066H	通道B高湿报警返回值设定 High humidity alarm return value of Channel B	R/W	10~99%	Word
0067H	继电器告警延迟时间 Alarm delay	R/W	1.0-20.0 s (*10)	Word
0068H-0069H	——	R/W	——	
006AH	强制加热时间 Manual heating time	R/W	0~120min 0: 不加热 0~120min 0: Manual heating not performed	
6BH~199H	保留 Reserved		保留 Reserved	
200H	工作语言: Language:	R/W	0: 中文 1: 英文 0: Chine 1: English	Word
201H	密码1 Password 1	R/W	0-9999	Word
202H	密码2 Password 2	R/W	0-9999	Word
203H	轮询时间 Polling time	R/W	0~9999s 0: 不轮询 0~9999s 0: no poll	Word
204H	通讯数据位 Communication data bits	R/W	8~9	Word
205H	通讯停止位 Communication stop bit	R/W	0~2: 0: 1停止位 1: 1.5停止位 2: 2停止位 0~2: 0: 1 stop bit 1: 1.5 stop bit 2: 2 stop bit	Word
206H	通讯奇偶校验位 parity checkbit	R/W	0~2: 0: 无奇偶校验 1: 奇校验 2: 偶校验 0~2: 0: No parity 1: Odd parity 2: Even parity	Word
207H	无线通讯波特率 Wireless baud rate	R/W	2400、4800、9600、19200	Word
208H	无线通讯数据位 Wireless communication data bit	R/W	8~9	Word
209H	无线通讯停止位 Wireless	R/W	0~2: 0: 1停止位 1: 1.5停止位 2: 2停止位 0~2: 0: 1 stop bit 1: 1.5 stop bit 2: 2 stop	Word

	communication stop bit		bit	
20AH	无线通讯奇偶校验位 Wireless communication parity check bit	R/W	0~2: 0: 无奇偶校验 1: 奇校验 2: 偶校验 0~2: 0: No parity 1: Odd parity 2: Even parity	Word
20BH	无线测温传感器组 1 返回值 return value of Wireless temperature sensor group 1	R/W	0~125℃	Word
20CH	无线测温传感器组 2 返回值 return value of Wireless temperature sensor group 2	R/W	0~125℃	Word
20DH	无线测温传感器组 3 返回值 return value of Wireless temperature sensor group 3	R/W	0~125℃	Word
20EH	无线测温传感器组 4 返回值 return value of Wireless temperature sensor group 4	R/W	0~125℃	Word
20FH	DO1 工作模式 DO1 output mode	R/W	0: off 1: on 2: def.:normal	Word
210H	DO2 工作模式 DO2 output mode	R/W	0: off 1: on 2: def.:normal	Word
211H	DO3 工作模式 DO3 output mode	R/W	0: off 1: on 2: def.:normal	Word
212H	DO4 工作模式 DO4 output mode	R/W	0: off 1: on 2: def.:normal	Word
213H	DO5 工作模式 DO5 output mode	R/W	0: off 1: on 2: def.:normal	Word
214H	DO6 工作模式 DO6 output mode	R/W	0: off 1: on 2: def.:normal	Word
215H	合闸 LED 灯配置 CB On LED configuration	R/W	0~24:对应 1~25 号灯 0~24 corresponding:1 ~ 25 lights	Word
216H	语音音量	R/W	0-7	Word

	Voice volume			
217H~21AH	保留 Reserved	R/W	保留 Reserved	Word
21BH	合闸电压 closing circuit control voltage	R	0-6553.5V (*10)	Word
21CH	分闸电压 tripping circuit control voltage	R	0-6553.5V (*10)	Word
21DH	断路器分合次数 CB tripping and closing numbers	R	0~65535	Word
21EH	分合闸电压报警 Tripping/closing control voltage alarm	R	1:分闸过压 2:合闸过压 1: over voltage alarm of tripping control voltage 2: over voltage alarm of closing control voltage	Word
21FH	无线测温传感器类 型 Wireless temperature sensor type	R	0: ATE100 1:ATE300 0xff:未检测到传感器 0: ATE100 1:ATE300 0xff:wireless sensor offline	Word
220H~22BH	外部无线测温传感 器的 ID 号 ID of wireless temperature sensor	R	0~FFFF: 有 ID 号: 检测到外部存在, 但未绑定的 ID 号 0xFFFF: 未检测到绑定的 ID 号 0~FFFF: With ID number: An externally detected but unbound ID number 0xFFFF: No bound ID number detected	Word
22CH~237H	无线测温传感器状 态 Wireless temperature sensor status	R	0~0xFFFF 有 ID 号: 已检测到节点对应 ID 号存在 0xFFFF: 未检测到节点对应 ID 号存在 0~0xFFFF ID is detected: the sensor of the detected ID is online 0xFFFF: the sensor is offline	Word

注: [1] R—只读; R/W—可读, 可写。

[2] ×10, ×100, ×1000—读取时实际值乘以相应的倍数上传, 写入时应乘以相应的倍数写入。

Note: [1] R-Read only; R/W-Readable, writable.

[2] ×10, ×100, ×1000-When reading, upload with practical value multiply corresponding times;
when writing, write in by multiplying corresponding times.

4 常见故障的诊断分析与排除方法

4 Diagnostic analysis and troubleshooting of common faults

4.1 辅助电源故障

4.1 Fault of auxiliary power supply

装置接通辅助电源后屏幕不亮？

The screen does not light after connecting the auxiliary power supply.

可能原因：外接端子线序错误。

Possible cause: the external terminal line sequence is wrong.

处理方法：拔出“温湿度 I”，“温湿度 II”，“无线测温”接口处的外接模块，重新上电装置判断。

Handling method: pull out the external module at the joint of “temperature and humidity I”, “temperature and humidity II”, “wireless temperature measuring” and re-power on to judge.

4.2 环境温湿度显示故障

4.2 Fault of environment temperature and humidity display

温湿菜单下环境温湿度值无显示或显示“rupt”？

The environment and humidity value under temperature and humidity menu has no display or displays “rupt”?

可能原因：温湿度控制字未投入或温湿度模块未接好。

Possible cause: The temperature and humidity control word is not input or temperature and humidity module is not well connected.

处理方法：

Handling method:

1) 无显示时：“参数->定值”菜单将“温湿 1 投退”或“温湿 2 投退”设置为投入。

1) When there is no display: “parameter -->definite value” menu will set the “temperature and humidity 1 out-of-service” or “temperature and humidity 2 out-of-service” as in-service.

2) 显示“rupt”时：检查“温湿度 I”，“温湿度 II”接口处的温湿度模块接入是否正确？

2) When displaying “rupt”: check whether the temperature and humidity module is correctly connected at the joint of “temperature and humidity I”, “temperature and humidity II”.

4.3 告警继电器动作故障

4.3 Fault of alarm relay operation

欠压，过压，过流，环境温度超温，无线节点温度高温定值越限而告警继电器不动作？

Undervoltage, overvoltage, environment temperature exceeds, wireless node high temperature definite value is out-of-limit and alarm relay does not work.

可能原因：相应的控制字未投入。

Possible cause: corresponding control word is not input.

处理方法：“参数->定值”菜单将相应的控制字设置为投入。

Handling method: “Parameter-->” menu should set corresponding control word as input.

4.4 一次模拟状态指示灯故障

4.4 Fault of primary simulated status indicator light

开关量输入与状态指示灯不对应或状态指示灯不亮？

Switch input and status indicator light is not corresponding or status indicator light is not on.

可能原因：状态指示灯设置错误。

Possible cause: status indicator light setting is wrong.

处理方法：“参数->状态指示”设置状态指示灯对应的开关量，如需常亮的设置为“ON”，未使用的设置为“OFF”。

Handling method: “Parameter--> status indicator” should set corresponding switch quantity of status indicator light. For example, if it needs normally on, set it as “ON”; if it is not used, set it as “OFF”.

4.5 通信故障

4.5 Communication fault

上位机或后台软件与装置通信错误？

There is something wrong with communication between upper computer or background software with device.

可能原因：装置地址或串口参数设置错误。

Possible cause: Device address or serial port parameter setting is wrong.

处理方法：“参数->通信”设置正确的装置地址或串口参数。

Handling method: “Parameter--> communication” should set correct device address or serial port parameters.

4.6 节点温度值显示故障

4.6 Fault of node temperature value display

ASD 主体“节温”菜单无温度值显示或无某一路温度值显示？

ASD main body “thermostat” menu has no temperature value display or no temperature value display of some path.

可能原因：电池开关未打开或传感器不配对。

Possible cause: battery switch is not opened or sensor is mismatched.

处理方法：

Handling method:

1) 查看无线温度传感器的电池开关是否拨到“ON”端？（电池开关从 OFF 端拨到 ON 端后，无线温度传感器上的绿灯亮灭闪烁 2 次表示开关接通正常，否则重复拨动）。

- 1) Check whether the battery switch of wireless temperature sensor is dialed to “ON” terminal (after battery switch is dialed to ON terminal from OFF terminal, the green light on wireless temperature sensor will flicker twice and it means that the switch is connected normally;

otherwise, re-dial it0.

2) 查看 ASD 主体上的条码与无线温度传感器上的条码是否一致，不一致时找到对应的无线温度传感器更换或重新配对无线温度传感器（详见本说明书 2.2.6 章节下的“ASD 主体与无线温度传感器的配对及校准”部分）。

2) Check whether the code on ASD main body and wireless temperature sensor is consistent. When it is inconsistent, find out corresponding wireless temperature sensor to replace or rematch wireless temperature sensor (See “Matching and calibration of ASD main body and wireless temperature sensor” part under Section 2.2.6 of the specification).

总部：安科瑞电气股份有限公司

Headquarter: Acrel Co., LTD.

地址：上海市嘉定区育绿路 253 号

Address: No.253 Yulv Road Jiading District, Shanghai, China

电话：0086-21-69158338 0086-21-69156052 0086-21-59156392 0086-21-69156971

TEL.: 0086-21-69158338 0086-21-69156052 0086-21-59156392 0086-21-69156971

传真：0086-21-69158303

Fax: 0086-21-69158303

网址：www.acrel-electric.com

Web-site: www.acrel-electric.com

邮箱：ACREL008@vip.163.com

Email: ACREL008@vip.163.com

邮编：201801

Postcode: 201801

生产基地：江苏安科瑞电器制造有限公司

Manufacturer: Jiangsu Acrel Electrical Manufacturing Co., LTD.

地址：江苏省江阴市南闸街道东盟工业园区东盟路 5 号

Address : No.5 Dongmeng Road,Dongmeng industrial Park, Nanzha Street,Jiangyin City,Jiangsu Province,China

电话：0086-510-86179966

TEL: 0086-510-86179966

传真：0086-510-86179975

Fax: 0086-510-86179975

网址：www.jsacrel.com

Web-site: www.jsacrel.com

邮箱：sales@email.acrel.cn

Email: sales@email.acrel.cn

邮编：214405

Postcode: 214405