

1.4 卡套90° 直角接头

卡套90° 承插焊直角

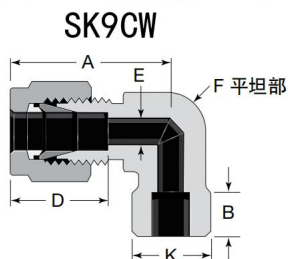

卡套管承插焊

卡套管 外径	承插焊 尺寸	基本 订购号	尺寸					
			A	B	D	E	F	K
尺寸, in.								
1/4	1/4	SK9CW-04-04	1.06	0.28	0.60	0.19	1/2	0.50
3/8	3/8	SK9CW-06-06	1.20	0.31	0.66	0.28	5/8	0.63
1/2	1/2	SK9CW-08-08	1.42	0.38	0.90	0.41	13/16	0.81
3/4	3/4	SK9CW-12-12	1.57	0.44	0.96	0.62	1 1/16	1.06
1	1	SK9CW-16-16	1.93	0.62	1.23	0.88	1 3/8	1.38

卡套90° 管外焊直角
SK9GW

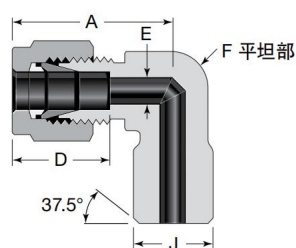

公称管外焊

卡套管 外径	公称管 焊接 尺寸	基本 订购号	尺寸				
			A	D	E ^①	F	J
尺寸, in.							
1/4	1/8 1/4	SK9GW-04-02 SK9GW-04-04	1.06	0.60	0.19	1/2	0.405 0.540
3/8	1/4	SK9GW-06-04	1.20	0.66	0.28	5/8	0.540
1/2	1/2	SK9GW-08-08	1.42	0.90	0.41	13/16	0.840
3/4	3/4	SK9GW-12-12	1.57	0.96	0.62	1 1/16	1.050

① 尺寸 E 是最小公称孔口。这些接头在焊接端可能会有更大的孔口。焊接端的壁厚基于规格 80 的公称管。

SK9NF

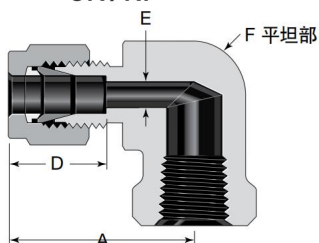

卡套90° 内螺纹直角
SK9NF

NPT

卡套管 外径	NPT 尺寸	基本 订购号	尺寸			
			A	D	E	F
尺寸, in.						
1/8	1/8	SK9NF-02-02	0.97	0.50	0.09	1/2
	1/4	SK9NF-02-04	1.08			11/16
3/16	1/8	SK9NF-03-02	1.00	0.54	0.12	1/2
		SK9NF-03-04	1.11			11/16
1/4	1/8	SK9NF-04-02	1.06	0.60	0.19	1/2
	1/4	SK9NF-04-04	1.17			11/16
	3/8	SK9NF-04-06	1.25			13/16
	1/2	SK9NF-04-08	1.36			1
5/16	1/8	SK9NF-05-02	1.13	0.64	0.25	9/16
	1/4	SK9NF-05-04	1.20			11/16
3/8	1/8	SK9NF-06-02	1.20	0.66	0.28	5/8
	1/4	SK9NF-06-04	1.23			11/16
	3/8	SK9NF-06-06	1.31			13/16
	1/2	SK9NF-06-08	1.42			1
1/2	1/4	SK9NF-08-04	1.42	0.90	0.41	13/16
	3/8	SK9NF-08-06	1.42			13/16
	1/2	SK9NF-08-08	1.53			1
5/8	3/8	SK9NF-10-06	1.50	0.96	0.50	15/16
	1/2	SK9NF-10-08	1.57			1 1/16
3/4	1/2	SK9NF-12-08	1.57	0.96	0.62	1 1/16
	3/4	SK9NF-12-12	1.76			1 3/8
7/8	3/4	SK9NF-14-12	1.76	1.02	0.72	1 3/8
		SK9NF-14-16	1.87			1 1/2
1	3/4	SK9NF-16-12	1.93	1.23	0.88	1 3/8
	1	SK9NF-16-16	2.11			1 11/16

卡套管 外径	NPT 尺寸 in.	基本 订购号	尺寸			
			A	D	E	F, in.
尺寸, mm						
6	1/8	SK9NF-6M-02	27.0	15.3	4.8	1/2
	1/4	SK9NF-6M-04	29.8			11/16
	1/2	SK9NF-6M-08	34.6			1
8	1/4	SK9NF-8M-04	30.6	16.2	6.4	11/16
10	1/8	SK9NF-10M-02	31.5	17.2	7.9	11/16
	1/4	SK9NF-10M-04	33.5			13/16
12	1/4	SK9NF-12M-04	36.0	22.8	9.5	13/16
	1/2	SK9NF-12M-08	38.8			1
16	1/2	SK9NF-16M-08	39.5	24.4	12.7	1 1/16

1.5 卡套45° 弯通接头

卡套45° 外螺纹弯通
SK4NM

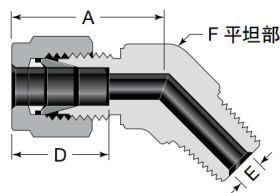

NPT

卡套管 外径	NPT 尺寸	基本 订购号	尺寸			
			A	D	E ^①	F
尺寸, in.						
1/4	1/8 1/4	SK4NM-04-02 SK4NM-04-04	0.97	0.60	0.19	1/2
3/8	1/8	SK4NM-06-02	1.10	0.66	0.19	5/8
	1/4	SK4NM-06-04	1.10		0.28	5/8
	3/8	SK4NM-06-06	1.15		0.28	13/16
1/2	3/8	SK4NM-08-06	1.26	0.90	0.38	13/16
	1/2	SK4NM-08-08			0.41	
3/4	3/4	SK4NM-12-12	1.33	0.96	0.62	1 1/16
1	1	SK4NM-16-16	1.59	1.23	0.88	1 3/8

① 尺寸 E 是最小公称孔口。这些接头在管螺纹/直螺纹端可能会有更大的孔口。

备注：4-45° 弯头

1.6 卡套三通接头

卡套三通
SKT

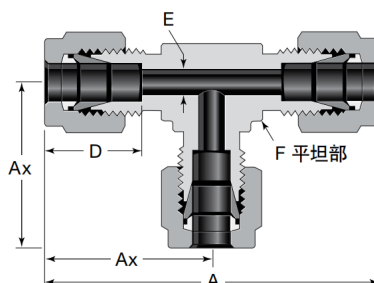

卡套管 外径	基本 订购号	尺寸				
		A	Ax	D	E	F
尺寸, in.						
1/16	SKT-01	1.40	0.70	0.34	0.05	3/8
1/8	SKT-02	1.76	0.88	0.50	0.09	3/8
3/16	SKT-03	1.92	0.96	0.54	0.12	7/16
1/4	SKT-04	2.12	1.06	0.60	0.19	1/2
5/16	SKT-05	2.34	1.17	0.64	0.25	5/8
3/8	SKT-06	2.40	1.20	0.66	0.28	5/8
1/2	SKT-08	2.84	1.42	0.90	0.41	13/16
5/8	SKT-10	3.06	1.53	0.96	0.50	1
3/4	SKT-12	3.14	1.57	0.96	0.62	1 1/16
7/8	SKT-14	3.52	1.76	1.02	0.72	1 3/8
1	SKT-16	3.86	1.93	1.23	0.88	1 3/8
1 1/8	SKT-18	4.34	2.17	1.23	0.97	1 11/16
1 1/4	SKT-20	5.34	2.67	1.62	1.09	1 11/16
1 1/2	SKT-24	6.20	3.10	1.97	1.34	2
2	SKT-32	8.44	4.22	2.66	1.81	2 3/4

卡套管 外径	基本 订购号	尺寸				
		A	Ax	D	E	F, in.
尺寸, mm						
2	SKT-2M	44.7	22.3	12.9	1.7	3/8
3	SKT-3M	44.7	22.3	12.9	2.4	3/8
4	SKT-4M	50.8	25.4	13.7	2.4	1/2
6	SKT-6M	53.9	27.0	15.3	4.8	1/2
8	SKT-8M	59.7	29.9	16.2	6.4	5/8
10	SKT-10M	63.0	31.5	17.2	7.9	11/16
12	SKT-12M	72.0	36.0	22.8	9.5	13/16
14	SKT-14M	77.6	38.8	24.4	11.1	1
15	SKT-15M	77.6	38.8	24.4	11.9	1
16	SKT-16M	77.6	38.8	24.4	12.7	1
18	SKT-18M	79.6	39.8	24.4	15.1	1 1/16
20	SKT-20M	89.3	44.6	26.0	15.9	1 3/8
22	SKT-22M	89.3	44.6	26.0	18.3	1 3/8
25	SKT-25M	98.3	49.1	31.3	21.8	1 3/8
28	SKT-28M	128	64.0	36.6	21.8	41 mm
30	SKT-30M	140	69.9	39.6	26.2	46 mm
32	SKT-32M	145	72.3	42.0	28.6	46 mm
38	SKT-38M	168	84.0	49.4	33.7	55 mm
50	SKT-50M	211	106	65.0	45.2	2 3/4

备注：T-三通接头

1.6 卡套三通接头

卡套变径三通
SKTB

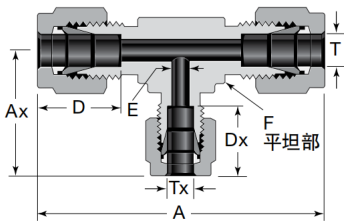

卡套变径三通
SKTB

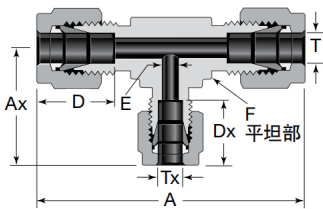

卡套变径三通
SKTB

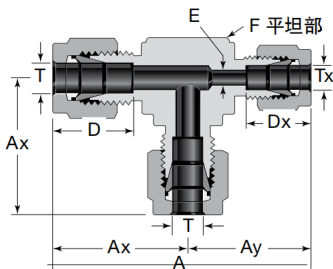

卡套变径三通
SKTB

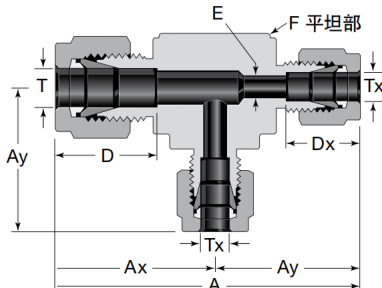

卡套管外径		基本 订购号	尺寸					
T	Tx		A	Ax	D	Dx	E	F
尺寸, in.								
3/8	1/4	SKTB-06-04-06	2.40	1.14	0.66	0.60	0.19	5/8
1/2	1/4	SKTB-08-04-08	2.84	1.25	0.90	0.60	0.19	13/16
	3/8	SKTB-08-06-08		1.31		0.66	0.28	
5/8	3/8	SKTB-10-06-10	3.06	1.42	0.96	0.66	0.28	1
3/4	3/8	SKTB-12-06-12	3.14	1.46	0.96	0.66	0.28	1 1/16
	1/2	SKTB-12-08-12		1.57		0.90	0.41	
1	3/8	SKTB-16-06-16	3.86	1.65	1.23	0.66	0.28	1 3/8
	1/2	SKTB-16-08-16		1.76		0.90	0.41	
	3/4	SKTB-16-12-16		1.76		0.96	0.62	
1 1/4	1	SKTB-20-16-20	5.34	2.17	1.62	1.23	0.88	1 11/16
1 1/2	1	SKTB-24-16-24	6.20	2.36	1.97	1.23	0.88	2
2	1	SKTB-32-16-32	8.44	2.79	2.66	1.23	0.88	2 3/4

备注: TB-变径三通

卡套管外径		基本 订购号	尺寸					
T	Tx		A	Ax	D	Dx	E	F, in.
尺寸, mm								
3	6	SKTB-3M-6M-3M	49.3	26.9	12.9	15.3	2.4	1/2
8		SKTB-8M-6M-8M	59.9	29.0	16.2	15.3	4.8	5/8
10		SKTB-10M-6M-10M	63.0	29.7	17.2	15.3	4.8	11/16
12		SKTB-12M-6M-12M	72.0	31.8	22.8	15.3	4.8	13/16
15	12	SKTB-15M-12M-12M	77.7	38.9	24.4	22.8	9.5	1
16		SKTB-16M-12M-16M	77.6	38.9	24.4	22.8	9.5	1
18		SKTB-18M-12M-18M	79.8	39.9	24.4	22.8	9.5	1 1/16
22		SKTB-22M-12M-22M	89.4	44.7	26.0	22.8	9.5	1 3/8
25		SKTB-25M-12M-25M	98.0	44.7	31.3	22.8	9.5	1 3/8

卡套管外径		基本 订购号	尺寸						
T	Tx		A	Ax	Ay	D	Dx	E	F
尺寸, in.									
3/8	1/4	SKTB-06-06-04	2.34	1.20	1.14	0.66	0.60	0.19	5/8

卡套管外径		基本 订购号	尺寸						
T	Tx		A	Ax	Ay	D	Dx	E	F
尺寸, in.									
1/2	3/8	SKTB-08-06-06	2.73	1.42	1.31	0.90	0.66	0.28	13/16
5/8		SKTB-10-06-06	2.95	1.53	1.42	0.96	0.66	0.28	1
3/4		SKTB-12-06-06	3.03	1.57	1.46	0.96	0.66	0.28	1 1/16

1.6 卡套三通接头

卡套变径三通
SKTB

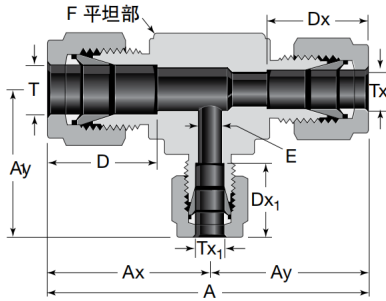

卡套管外径			基本 订购号	尺寸								
T	Tx	Tx ₁		A	Ax	Ay	Ay ₁	D	Dx	Dx ₁	E	F
尺寸, in.												
5/8	1/2		SKTB-10-06-08	3.06	1.53	1.53	1.42	0.96	0.90			1
3/4	1/2	3/8	SKTB-12-06-08	3.14	1.57	1.57	1.46	0.96	0.90	0.66	0.28	1 1/16
1	3/4		SKTB-16-06-12	3.69	1.93	1.76	1.65	1.23	0.96			1 3/8

卡套变径外螺纹三通
SKTBNM

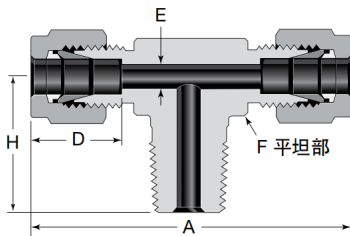

NPT(KMK)

卡套管 外径	NPT 尺寸 in.	基本 订购号	尺寸				
			A	D	E ^①	F, in.	H
尺寸, in.							
1/8	1/8 1/4	SKTB-02-02NM-02 SKTB-02-04NM-02	1.86 1.94	0.50	0.09	7/16 1/2	0.70 0.92
3/16	1/8	SKTB-03-02NM-03	1.92	0.54	0.12	7/16	0.70
1/4	1/8 1/4	SKTB-04-02NM-04 SKTB-04-04NM-04	2.12	0.60	0.19	1/2	0.74 0.92
5/16	1/8	SKTB-05-02NM-05	2.34	0.64	0.19	5/8	0.82
3/8	1/4 3/8	SKTB-06-04NM-06 SKTB-06-06NM-06	2.40 2.62	0.66	0.28	5/8 13/16	1.00 1.11
1/2	3/8 1/2	SKTB-08-06NM-08 SKTB-08-08NM-08	2.84	0.90	0.38 0.41	13/16	1.11 1.30
5/8	1/2	SKTB-10-08NM-10	3.06	0.96	0.47	1	1.41
3/4	3/4	SKTB-12-12NM-12	3.14	0.96	0.62	1 1/16	1.45
尺寸, mm							
6	1/8 1/4	SKTB-6M-02NM-6M SKTB-6M-04NM-6M	53.9	15.3	4.8	1/2	18.8 23.4
8	1/8 1/4	SKTB-8M-02NM-8M SKTB-8M-04NM-8M	59.7	16.2	4.8 6.4	5/8	20.8 25.4
10	1/4	SKTB-10M-04NM-10M	67.0	17.2	7.1	13/16	26.2
12	3/8 1/4 1/2	SKTB-12M-06NM-12M SKTB-12M-04NM-12M SKTB-12M-08NM-12M	72.0	22.8	9.5 7.1 9.5	13/16	28.2 28.2 33.0
16	1/2	SKTB-16M-08NM-16M	77.6	24.4	11.9	1	35.8

① 尺寸 E 是最小公称孔口。这些接头在管螺纹/直螺纹端可能会有更大的孔口。

NPT (KKM)

卡套管 外径	NPT 尺寸 in.	基本 订购号	尺寸				
			A	Ax	D	E ^①	F, in.
尺寸, in.							
1/8	1/8 1/4	SKTB-02-02-02NM SKTB-02-02-04NM	1.63 1.89	0.93 0.97	0.50	0.09	7/16 1/2
3/16	1/8	SKTB-03-03-02NM	1.66	0.96	0.54	0.12	7/16
1/4	1/8 1/4	SKTB-04-04-02NM SKTB-04-04-04NM	1.80 1.98	1.06	0.60	0.19	1/2
5/16	1/8	SKTB-05-05-02NM	1.99	1.17	0.64	0.19	5/8
3/8	1/4 3/8	SKTB-06-06-04NM SKTB-06-06-06NM	2.20 2.42	1.20 1.31	0.66	0.28	5/8 13/16
1/2	3/8 1/2	SKTB-08-08-06NM SKTB-08-08-08NM	2.53 2.72	1.42	0.90	0.38 0.41	13/16
5/8	1/2	SKTB-10-10-08NM	2.88	1.50	0.96	0.47	15/16
3/4	3/4	SKTB-12-12-12NM	3.02	1.57	0.96	0.62	1 1/16
尺寸, mm							
6	1/8 1/4	SKTB-6M-6M-02NM SKTB-6M-6M-04NM	45.8 50.3	27.0	15.3	4.8	1/2
8	1/4	SKTB-8M-8M-04NM	55.3	29.9	16.2	6.4	5/8
12	1/4 1/2	SKTB-12-12-04NM SKTB-12-12-08NM	64.2 69.0	36.0	22.8	7.1 9.5	13/16
16	1/2	SKTB-16-16-08NM	73.1	38.0	24.4	11.9	15/16

① 尺寸 E 是最小公称孔口。这些接头在管螺纹/直螺纹端可能会有更大的孔口。

备注：三通变径接头规格按左中右编码

1.6 卡套三通接头

卡套变径内螺纹三通
SKTBNF

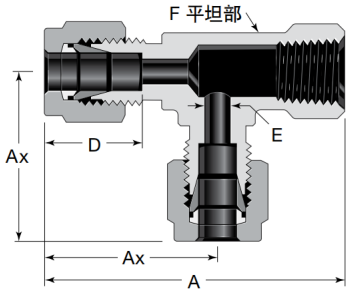

卡套管端口是相同的。

NPT(KKF)

卡套管 外径	NPT 尺寸 in.	基本 订购号	尺寸				
			A	Ax	D	E	F, in.
尺寸、in.							
1/8	1/8	SKTB-02-02-02NF	1.72	0.97	0.50	0.09	1/2
1/4	1/8	SKTB-04-04-02NF	1.81	1.06	0.60	0.19	1/2
	1/4	SKTB-04-04-04NF	2.05	1.17	0.60	0.19	11/16
3/8	1/4	SKTB-06-06-04NF	2.11	1.23	0.66	0.28	11/16
1/2	3/8	SKTB-08-08-06NF	2.30	1.42	0.90	0.41	13/16
	1/2	SKTB-08-08-08NF	2.69	1.57	0.90	0.41	1 1/16
3/4	3/4	SKTB-12-12-12NF	3.01	1.76	0.96	0.62	1 3/8
1	3/4	SKTB-16-16-12NF	3.18	1.93	1.23	0.88	1 3/8
	1	SKTB-16-16-16NF	3.61	2.11	1.23	0.88	1 11/16
尺寸、mm							
6	1/8	SKTB-6M-6M-02NF	46.0	27.0	15.3	4.8	1/2
	1/4	SKTB-6M-6M-04NF	52.1	29.8	15.3	4.8	11/16
8	1/8	SKTB-8M-8M-02NF	48.9	29.9	16.2	6.4	5/8
	1/4	SKTB-8M-8M-04NF	53.0	30.6	16.2	6.4	11/16
10	1/4	SKTB-10M-10M-04NF	55.9	33.5	17.2	7.9	13/16
12	1/4	SKTB-12M-12M-04NF	58.4	36.0	22.8	9.5	13/16
	3/8	SKTB-12M-12M-06NF	58.4	36.0	22.8	10.3	13/16
	1/2	SKTB-12M-12M-08NF	68.3	39.8	24.4	9.5	1 1/16
16	1/2	SKTB-16M-16M-08NF	68.2	39.8	24.4	12.7	1 1/16

卡套变径内螺纹三通
SKTBNF

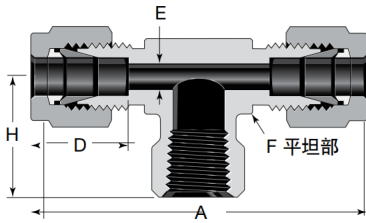

NPT (KFK)

卡套管 外径	NPT 尺寸 in.	基本 订购号	尺寸				
			A	D	E	F, in.	H
尺寸、in.							
1/8	1/8	SKTB-02-02NF-02	1.94	0.50	0.09	1/2	0.75
1/4	1/8	SKTB-04-02NF-04	2.12	0.60	0.19	1/2	0.75
	1/4	SKTB-04-04NF-04	2.34	0.60	0.19	11/16	0.88
3/8	1/4	SKTB-06-04NF-06	2.46	0.66	0.28	11/16	0.88
	3/8	SKTB-06-06NF-06	2.62	0.66	0.28	13/16	0.88
	1/2	SKTB-06-08NF-06	2.84	0.66	0.28	1	1.12
1/2	1/4	SKTB-08-04NF-08	2.84	0.90	0.41	13/16	0.88
	3/8	SKTB-08-06NF-08	2.84	0.90	0.41	13/16	0.88
	1/2	SKTB-08-08NF-08	3.06	0.90	0.41	1	1.12
5/8	1/2	SKTB-10-08NF-10	3.06	0.96	0.50	1	1.12
3/4	3/4	SKTB-12-12NF-12	3.52	0.96	0.62	1 3/8	1.25
1	3/4	SKTB-16-12NF-16	3.86	1.23	0.88	1 3/8	1.25
	1	SKTB-16-16NF-16	4.22	1.23	0.88	1 11/16	1.50
尺寸、mm							
6	1/8	SKTB-6M-02NF-6M	53.9	15.3	4.8	1/2	19.0
	1/4	SKTB-6M-04NF-6M	59.5	15.3	4.8	11/16	22.4
8	1/8	SKTB-8M-02NF-8M	59.7	16.2	6.4	5/8	19.0
	1/4	SKTB-8M-04NF-8M	61.2	16.2	6.4	11/16	22.4
10	1/4	SKTB-10M-04NF-10M	67.0	17.2	7.9	13/16	22.4
12	1/4	SKTB-12M-04NF-12M	72.0	22.8	9.5	13/16	22.4
	3/8	SKTB-12M-06NF-12M	72.0	22.8	9.5	13/16	22.4
	1/2	SKTB-12M-08NF-12M	77.7	24.4	9.5	1	28.4
16	1/2	SKTB-16M-08NF-16M	77.6	24.4	12.7	1	28.4

1.7 卡套四通接头

卡套四通
SKX

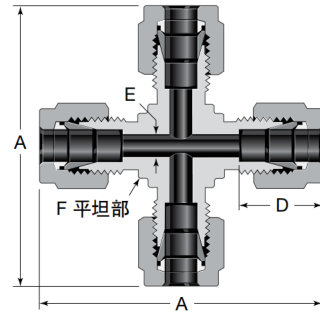

卡套管 外径	基本 订购号	尺寸			
		A	D	E	F, in.
尺寸、in.					
1/8	SKX-02	1.76	0.50	0.09	3/8
1/4	SKX-04	2.12	0.60	0.19	1/2
5/16	SKX-05	2.34	0.64	0.25	5/8
3/8	SKX-06	2.40	0.66	0.28	5/8
1/2	SKX-08	2.84	0.90	0.41	13/16
3/4	SKX-12	3.14	0.96	0.62	1 1/16
1	SKX-16	3.86	1.23	0.88	1 3/8
尺寸、mm					
3	SKX-3M	44.7	12.9	2.4	3/8
6	SKX-6M	53.9	15.3	4.8	1/2
8	SKX-8M	59.7	16.2	6.4	5/8
10	SKX-10M	67.0	17.2	7.9	13/16
12	SKX-12M	72.0	22.8	9.5	13/16
16	SKX-16M	74.0	24.4	12.7	15/16
18	SKX-18M	76.6	24.4	15.1	1 1/16
20	SKX-20M	89.3	26.0	15.9	1 3/8
22	SKX-22M	89.4	26.0	18.3	5/8
25	SKX-25M	98.3	31.3	21.8	1 3/8

备注：X-四通接头