

1.1 卡套接头特点

- 活动负载和双卡套设计。
- 易于安装。
- 安装时不会把扭矩传输到卡套管上。
- 间隙检测规确保了首次安装的充分紧固。

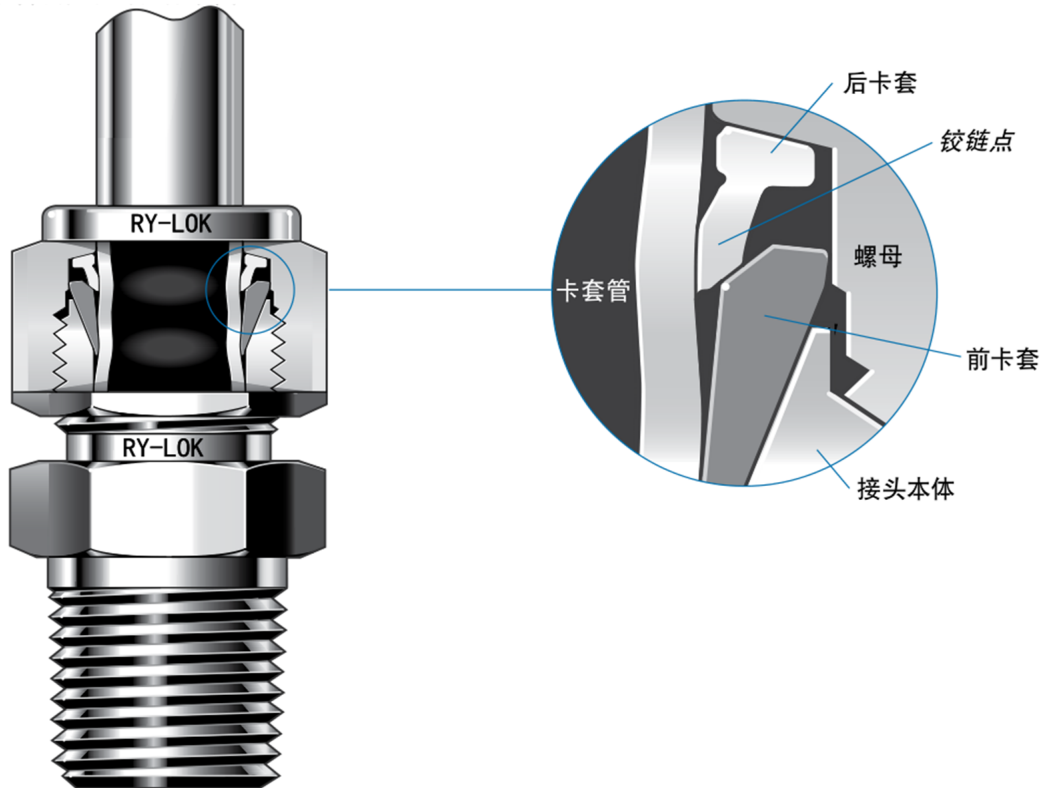

双卡套的机械式抓紧设计

双卡套将密封功能和对卡套管的抓紧功能分开，每个卡套都针对其相应的功能进行了优化。

前卡套用于形成密封：

- 与接头本体之间的密封
- 卡套管外径的密封。

旋转螺母时，后卡套将：

- 沿轴向推进前卡套
- 沿径向施加一个有效的卡套管抓紧。

铰链 - 夹箍作用的后卡套设计

这是 1/4 至 1/2 in. 和 6 至 12 mm 接头的标准设计，其目的是帮助安装人员完成更加坚固的防泄漏卡套管连接。

- 极佳的气体密封和卡套管抓紧作用
- 易于进行正确的安装
- 可靠的复装
- 极好的抗振动疲劳性能和卡套管支撑

1.2 卡套接头安装说明

预装工具

图 1



图 2



图 3



1. 把螺母和卡套安装到预装的工具上。
2. 把卡套管插入到预装工具内。
3. 确保卡套管稳固地靠在预装工具本体的肩部并且螺母已用手指拧紧。
4. 在 6 点钟的位置给螺母作标记。
5. 牢牢固定预装工具体，将螺母紧固一又四分之一圈以停在 9 点钟的位置。
对于 1/16、1/8 和 3/16 in.；2、3 和 4 mm 的卡套管接头，仅将螺母紧固四分之三圈以停在 3 点钟的位置(图1)。
6. 松开螺母。
7. 从预装工具上拆除带有预装卡套的卡套管。如果卡套管粘在预装工具上，轻轻地前后摇晃卡套管以便将其拆除。切勿旋转卡套管(图 2)。
8. 将带有预装卡套的卡套管插入接头内直到前卡套顶在接头本体上。
9. 牢牢固定接头本体，使用扳手把螺母转到先前紧固位置；这时，您会感觉到阻力明显增大。
10. 用扳手轻轻紧固(图 3)。

1.3 卡套直通接头

卡套直通
SKZ

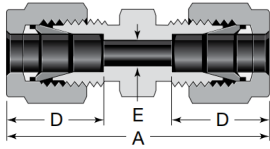

卡套变径直通
SKZB

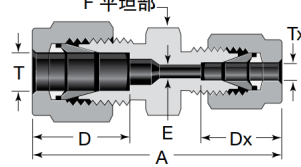

卡套直通

| 卡套管 外径 | 基本 订购号 | 尺寸 | | |
|-----------|-----------|------|------|------|
| | | A | D | E |
| 尺寸, in. | | | | |
| 1/16 | SKZ-01 | 0.99 | 0.34 | 0.05 |
| 1/8 | SKZ-02 | 1.40 | 0.50 | 0.09 |
| 3/16 | SKZ-03 | 1.47 | 0.54 | 0.12 |
| 1/4 | SKZ-04 | 1.61 | 0.60 | 0.19 |
| 5/16 | SKZ-05 | 1.69 | 0.64 | 0.25 |
| 3/8 | SKZ-06 | 1.77 | 0.66 | 0.28 |
| 1/2 | SKZ-08 | 2.02 | 0.90 | 0.41 |
| 1/2 | SKZCK-08 | 4.30 | — | 0.50 |
| 5/8 | SKZ-10 | 2.05 | 0.96 | |
| 3/4 | SKZ-12 | 2.11 | | 0.62 |
| 7/8 | SKZ-14 | 2.17 | 1.02 | 0.72 |
| 1 | SKZ-16 | 2.55 | 1.23 | 0.88 |
| 1 1/8 | SKZ-18 | | | 0.97 |
| 1 1/4 | SKZ-20 | | | 1.09 |
| 1 1/2 | SKZ-24 | 4.25 | 1.97 | 1.34 |
| 2 | SKZ-32 | 5.88 | 2.66 | 1.81 |
| 尺寸, mm | | | | |
| 2 | SKZ-2M | 35.6 | 12.9 | 1.7 |
| 3 | SKZ-3M | 35.3 | | 2.4 |
| 4 | SKZ-4M | 37.3 | 13.7 | 4.8 |
| 6 | SKZ-6M | 41.0 | 15.3 | 6.4 |
| 8 | SKZ-8M | 43.2 | 16.2 | 7.9 |
| 10 | SKZ-10M | 46.2 | 17.2 | 9.5 |
| 12 | SKZ-12M | 51.2 | 22.8 | 11.1 |
| 14 | SKZ-14M | 52.0 | 24.4 | 11.9 |
| 15 | SKZ-15M | | | 12.7 |
| 16 | SKZ-16M | | | 15.1 |
| 18 | SKZ-18M | 53.5 | 26.0 | 15.9 |
| 20 | SKZ-20M | 55.0 | 26.0 | 18.3 |
| 22 | SKZ-22M | | | 21.8 |
| 25 | SKZ-25M | 65.0 | 31.3 | 26.2 |
| 28 | SKZ-28M | 85.0 | 36.6 | 28.6 |
| 30 | SKZ-30M | 92.7 | 39.6 | 33.7 |
| 32 | SKZ-32M | 97.3 | 42.0 | 45.2 |
| 38 | SKZ-38M | 114 | 49.4 | 50.8 |
| 50 | SKZ-50M | 146 | 65.0 | 63.5 |

卡套变径

| 卡套管外径 | | 基本 订购号 | 尺寸 | | | | |
|--------|------------|--------------------------|--------------|------|--------------|------------|----------|
| T | Tx, in. | | A | D | Dx | E | F |
| 尺寸, mm | | | | | | | |
| 2 | 1/8 1/4 | SKZB-2M-02 SKZB-2M-04 | 35.2 38.6 | 12.9 | 12.8 15.3 | 1.7 | 12 14 |
| 3 | 1/8 | SKZB-3M-02 | 35.2 | 12.9 | 12.8 | 2.4 | 12 |
| 4 | 1/8 1/4 | SKZB-4M-02 SKZB-4M-04 | 36.5 39.4 | 13.7 | 12.8 15.3 | 2.4 | 12 14 |
| 6 | 1/16 | SKZB-6M-01 | 34.3 | 15.3 | 8.6 | 1.3 | 14 |
| | 1/8 | SKZB-6M-02 | 38.5 | | 12.8 | 2.4 | 14 |
| | 1/4 | SKZB-6M-04 | 41.0 | | 15.3 | 4.8 | 14 |
| | 5/16 | SKZB-6M-05 | 42.3 | | 16.2 | 4.8 | 14 |
| 8 | 3/8 | SKZB-6M-06 | 43.2 | 16.8 | 4.8 | 16 | |
| | 1/4 3/8 | SKZB-8M-04 SKZB-8M-06 | 42.3 44.3 | 16.2 | 15.3 16.9 | 4.8 6.4 | 15 16 |
| 10 | 1/8 | SKZB-10M-02 | 41.8 | 17.2 | 12.8 | 2.4 | 18 |
| | 1/4 | SKZB-10M-04 | 44.5 | | 15.3 | 4.8 | |
| | 5/16 | SKZB-10M-05 | 45.1 | | 16.2 | 6.4 | |
| | 3/8 | SKZB-10M-06 | 45.9 | | 16.9 | 7.1 | |
| 12 | 1/4 | SKZB-12M-04 | 47.0 | 22.8 | 15.3 | 4.8 | 22 |
| | 5/16 | SKZB-12M-05 | 47.8 | | 16.2 | 6.4 | |
| | 3/8 | SKZB-12M-06 | 48.4 | | 16.9 | 7.1 | |
| | 1/2 | SKZB-12M-08 | 51.2 | | 22.8 | 9.5 | |
| 15 | 1/2 | SKZB-15M-08 | 52.0 | 24.4 | 22.8 | 10.3 | 24 |
| 16 | 5/8 | SKZB-16M-10 | 52.0 | 24.4 | 24.4 | 12.7 | 24 |
| 18 | 3/4 | SKZB-18M-12 | 53.5 | 24.4 | 24.4 | 15.1 | 27 |
| 20 | 1/2 | SKZB-20M-08 | 55.0 | 26.0 | 22.8 | 10.3 | 30 |
| | 1 | SKZB-20M-16 | 62.8 | | 31.3 | 15.9 | 35 |
| 25 | 1 | SKZB-25M-16 | 65.0 | 31.3 | 31.3 | 21.8 | 35 |

如何订购

选择一基本订购号。例如: SKZ-02

再加上一个材料代号, 例如: **SS**-SKZ-02

| 材料 | 代号 | 材料 | 代号 |
|--------|-----|----------|----|
| 316不锈钢 | SS | 合金 C-276 | HC |
| 铝 | A | 黄铜 | B |
| 合金 20 | C20 | 碳钢 | S |
| 合金 400 | M | 尼龙 | NY |
| 合金 600 | INC | PTFE | T |
| 合金 625 | 625 | 钛(等级 4) | TI |
| 合金 825 | 825 | | |

备注: SK-双卡套
Z-直通
ZB-直通变径
CK-穿孔
M-公制管径

1.3 卡套直通接头

卡套变径直通
SKZB

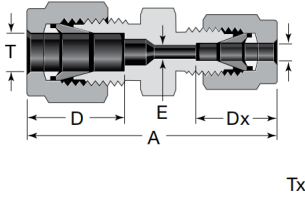

| 卡套管外径 | | 基本 订购号 | 尺寸 | | | |
|--------|------|--------------|------|------|------|------|
| T | Tx | | A | D | Dx | E |
| 尺寸、in. | | | | | | |
| 1/8 | 1/16 | SKZB-04-02 | 1.22 | 0.50 | 0.34 | 0.05 |
| 3/16 | 1/16 | SKZB-03-01 | 1.27 | 0.54 | 0.34 | 0.05 |
| | 1/8 | SKZB-03-02 | 1.44 | | 0.50 | 0.09 |
| 1/4 | 1/16 | SKZB-04-01 | 1.35 | 0.60 | 0.34 | 0.05 |
| | 1/8 | SKZB-04-02 | 1.52 | | 0.50 | 0.09 |
| | 3/16 | SKZB-04-03 | 1.55 | | 0.54 | 0.12 |
| 5/16 | 1/8 | SKZB-05-02 | 1.56 | 0.64 | 0.50 | 0.09 |
| | 1/4 | SKZB-05-04 | 1.66 | | 0.60 | 0.19 |
| 3/8 | 1/16 | SKZB-06-01 | 1.44 | 0.66 | 0.34 | 0.05 |
| | 1/8 | SKZB-06-02 | 1.61 | | 0.50 | 0.09 |
| | 1/4 | SKZB-06-04 | 1.70 | | 0.60 | 0.19 |
| | 5/16 | SKZB-06-05 | 1.74 | | 0.64 | 0.25 |
| 1/2 | 1/8 | SKZB-08-02 | 1.78 | 0.90 | 0.50 | 0.09 |
| | 1/4 | SKZB-08-04 | 1.85 | | 0.60 | 0.19 |
| | 3/8 | SKZB-08-06 | 1.91 | | 0.66 | 0.28 |
| 5/8 | 3/8 | SKZB-10-06 | 1.94 | 0.96 | 0.66 | 0.28 |
| | 1/2 | SKZB-10-08 | 2.05 | | 0.90 | 0.41 |
| 3/4 | 1/4 | SKZB-12-04 | 1.94 | 0.96 | 0.60 | 0.19 |
| | 3/8 | SKZB-12-06 | 2.00 | | 0.66 | 0.28 |
| | 1/2 | SKZB-12-08 | 2.11 | | 0.90 | 0.41 |
| | 5/8 | SKZB-12-10 | 2.11 | | 0.96 | 0.50 |
| 1 | 1/2 | SKZB-16-08 | 2.38 | 1.23 | 0.90 | 0.41 |
| | 3/4 | SKZB-16-12 | | | 0.96 | 0.62 |
| 尺寸、mm | | | | | | |
| 3 | 2 | SKZB-3M-2M | 35.3 | 12.9 | 12.9 | 1.7 |
| 6 | 2 | SKZB-6M-2M | 38.6 | 15.3 | 12.9 | 1.7 |
| | 3 | SKZB-6M-3M | 38.6 | | 12.9 | 2.4 |
| | 4 | SKZB-6M-4M | 39.4 | | 13.7 | 2.4 |
| 8 | 6 | SKZB-8M-6M | 42.3 | 16.2 | 15.3 | 4.8 |
| 10 | 6 | SKZB-10M-6M | 44.5 | 17.2 | 15.3 | 4.8 |
| | 8 | SKZB-10M-8M | 45.1 | | 16.2 | 6.4 |
| 12 | 6 | SKZB-12M-6M | 47.0 | 22.8 | 15.3 | 4.8 |
| | 8 | SKZB-12M-8M | 47.8 | | 16.2 | 6.4 |
| | 10 | SKZB-12M-10M | 48.7 | | 17.2 | 7.9 |
| 16 | 10 | SKZB-16M-10M | 45.9 | 24.4 | 17.2 | 7.9 |
| | 12 | SKZB-16M-12M | 52.0 | | 22.8 | 9.5 |
| 18 | 12 | SKZB-18M-12M | 53.5 | 24.4 | 22.8 | 9.5 |
| | 18 | SKZB-18M-18M | 53.5 | | 24.4 | 9.5 |
| 25 | 18 | SKZB-25M-18M | 61.0 | 31.3 | 24.4 | 15.1 |
| | 20 | SKZB-25M-20M | 62.3 | | 26.0 | 15.9 |
| 30 | 18 | SKZB-30M-18M | 75.4 | 39.6 | 24.4 | 15.1 |
| | 20 | SKZB-30M-20M | 75.4 | | 26.0 | 15.9 |
| | 25 | SKZB-30M-25M | 80.1 | | 31.3 | 21.8 |
| 32 | 18 | SKZB-32M-18M | 77.8 | 42.0 | 24.4 | 15.1 |
| | 20 | SKZB-32M-20M | 77.8 | | 26.0 | 15.9 |
| | 25 | SKZB-32M-25M | 82.3 | | 31.3 | 21.8 |
| 38 | 20 | SKZB-38M-20M | 87.5 | 49.4 | 26.0 | 15.9 |
| | 25 | SKZB-38M-25M | 92.0 | | 31.3 | 21.8 |
| | 30 | SKZB-38M-30M | 105 | | 39.6 | 26.2 |

1.3 卡套直通接头

卡套穿板直通
SKZCB

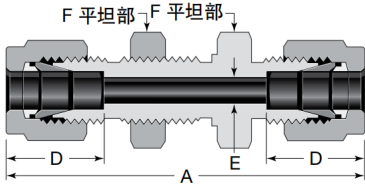

| 卡套管 外径 | 基本 订购号 | 尺寸 | | | | | | |
|-----------|-----------|------|------|------|--------|-----------|-------------------|------|
| | | A | D | E | F | 面板孔 尺寸 | 最大 面板厚度 | |
| 尺寸, in. | | | | | | | | |
| 1/16 | SKZCB-01 | 1.24 | 0.34 | 0.05 | 5/16 | 13/64 | 0.12 ^① | |
| 1/8 | SKZCB-02 | 2.02 | 0.50 | 0.09 | 1/2 | 21/64 | 0.50 | |
| 3/16 | SKZCB-03 | 2.11 | 0.54 | 0.12 | 9/16 | 25/64 | | |
| 1/4 | SKZCB-04 | 2.27 | 0.60 | 0.19 | 5/8 | 29/64 | 0.40 | |
| 5/16 | SKZCB-05 | 2.39 | 0.64 | 0.25 | 11/16 | 33/64 | 0.44 | |
| 3/8 | SKZCB-06 | 2.45 | 0.66 | 0.28 | 3/4 | 37/64 | | |
| 1/2 | SKZCB-08 | 2.80 | 0.90 | 0.41 | 15/16 | 49/64 | 0.50 | |
| 5/8 | SKZCB-10 | 2.86 | 0.96 | 0.50 | 1 1/16 | 57/64 | | |
| 3/4 | SKZCB-12 | 3.11 | 0.96 | 0.62 | 1 3/16 | 1 1/64 | 0.66 | |
| 1 | SKZCB-16 | 3.77 | 1.23 | 0.88 | 1 5/8 | 1 21/64 | 0.75 | |
| 1 1/4 | SKZCB-20 | 4.85 | 1.62 | 1.09 | 1 7/8 | 1 41/64 | | |
| 1 1/2 | SKZCB-24 | 5.48 | 1.97 | 1.34 | 2 1/4 | 1 61/64 | | |
| 2 | SKZCB-32 | 7.10 | 2.66 | 1.81 | 2 3/4 | 2 41/64 | | |
| 尺寸, mm | | | | | | | | |
| 3 | SKZCB-3M | 51.3 | 12.9 | 2.4 | 14 | 8.3 | 12.7 | |
| 4 | SKZCB-4M | 53.6 | 13.7 | 2.4 | | 9.9 | | |
| 6 | SKZCB-6M | 57.7 | 15.3 | 4.8 | 16 | 11.5 | 10.2 | |
| 8 | SKZCB-8M | 61.0 | 16.2 | 6.4 | 18 | 13.1 | 11.2 | |
| 10 | SKZCB-10M | 63.7 | 17.2 | 7.9 | 22 | 16.3 | | |
| 12 | SKZCB-12M | 71.0 | 22.8 | 9.5 | 24 | 19.5 | 12.7 | |
| 14 | SKZCB-14M | 72.5 | 24.4 | 11.1 | 27 | 22.5 | | |
| 15 | SKZCB-15M | 72.5 | 24.4 | 11.9 | | 22.8 | | |
| 16 | SKZCB-16M | 72.5 | 24.4 | 12.7 | 30 | 26.0 | 16.8 | |
| 18 | SKZCB-18M | 78.9 | 24.4 | 15.1 | | 30 | 29.0 | |
| 20 | SKZCB-20M | 84.5 | 26.0 | 15.9 | | 35 | 34.0 | 19.0 |
| 25 | SKZCB-25M | 96.0 | 31.3 | 21.8 | | 50 | 40.5 | |
| 30 | SKZCB-30M | 124 | 39.6 | 26.2 | 42.5 | | | |
| 32 | SKZCB-32M | 128 | 42.0 | 28.6 | 50.5 | | | |
| 38 | SKZCB-38M | 145 | 49.4 | 33.7 | 60 | 50.5 | | |

① 最小面板厚度为 0.06 in.

卡套穿板变径直通
SKZBCB

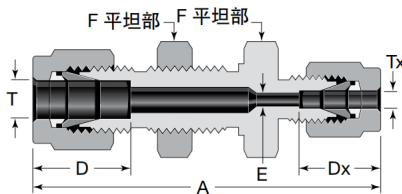

| 卡套管外径 | | 基本 订购号 | 尺寸 | | | | | | |
|---------|------|--------------|------|------|------|------|-------|-----------|------------|
| T | Tx | | A | D | Dx | E | F | 面板孔 尺寸 | 最大 面板厚度 |
| 尺寸, in. | | | | | | | | | |
| 1/8 | 1/16 | SKZBCB-02-01 | 1.85 | 0.50 | 0.34 | 0.05 | 1/2 | 21/64 | 0.50 |
| 1/4 | 1/8 | SKZBCB-04-02 | 2.17 | 0.60 | 0.50 | 0.09 | 5/8 | 29/64 | 0.40 |
| 3/8 | 1/4 | SKZBCB-06-04 | 2.39 | 0.66 | 0.60 | 0.19 | 3/4 | 37/64 | 0.44 |
| 1/2 | 1/4 | SKZBCB-08-04 | 2.63 | 0.90 | | | 15/16 | 49/64 | 0.50 |

| 卡套管外径 | | 基本 订购号 | 尺寸 | | | | | | |
|--------|---------|--------------|------|------|------|-----|----|-----------|------------|
| T | Tx, in. | | A | D | Dx | E | F | 面板孔 尺寸 | 最大 面板厚度 |
| 尺寸, mm | | | | | | | | | |
| 6 | 1/8 | SKZBCB-6M-02 | 55.1 | 15.3 | 12.7 | 2.4 | 16 | 11.5 | 10.2 |

备注: CB代表穿板接头

1.3 卡套直通接头

卡套外螺纹直通
SKZNM

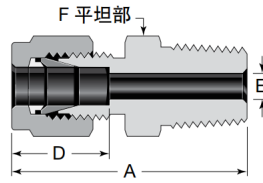

NPT

| 卡套管 外径 | NPT 尺寸 | 基本 订购号 | 尺寸 | | | |
|-----------|-----------|-------------|------|------|----------------|--------|
| | | | A | D | E ^① | F |
| 尺寸、in. | | | | | | |
| 1/16 | 1/16 | SKZNM-01-01 | 0.94 | 0.34 | 0.05 | 5/16 |
| | 1/8 | SKZNM-01-02 | 1.03 | | | 7/16 |
| | 1/4 | SKZNM-01-04 | 1.22 | | | 9/16 |
| 1/8 | 1/16 | SKZNM-02-01 | 1.17 | 0.50 | 0.09 | 7/16 |
| | 1/8 | SKZNM-02-02 | 1.20 | | | 7/16 |
| | 1/4 | SKZNM-02-04 | 1.40 | | | 9/16 |
| | 3/8 | SKZNM-02-06 | 1.41 | | | 11/16 |
| | 1/2 | SKZNM-02-08 | 1.66 | | | 7/8 |
| 3/16 | 1/8 | SKZNM-03-02 | 1.23 | 0.54 | 0.12 | 7/16 |
| | 1/4 | SKZNM-03-04 | 1.43 | | | 9/16 |
| 1/4 | 1/16 | SKZNM-04-01 | 1.29 | 0.60 | 0.12 | 1/2 |
| | 1/8 | SKZNM-04-02 | 1.29 | | | 1/2 |
| | 1/4 | SKZNM-04-04 | 1.49 | | | 9/16 |
| | 3/8 | SKZNM-04-06 | 1.51 | | | 11/16 |
| | 1/2 | SKZNM-04-08 | 1.76 | | | 7/8 |
| | 3/4 | SKZNM-04-12 | 1.82 | | | 1 1/16 |
| 5/16 | 1/8 | SKZNM-05-02 | 1.34 | 0.64 | 0.19 | 9/16 |
| | 1/4 | SKZNM-05-04 | 1.52 | | | 9/16 |
| | 3/8 | SKZNM-05-06 | 1.54 | | | 11/16 |
| 3/8 | 1/8 | SKZNM-06-02 | 1.39 | 0.66 | 0.19 | 5/8 |
| | 1/4 | SKZNM-06-04 | 1.57 | | | 5/8 |
| | 3/8 | SKZNM-06-06 | 1.57 | | | 11/16 |
| | 1/2 | SKZNM-06-08 | 1.82 | | | 7/8 |
| | 3/4 | SKZNM-06-12 | 1.88 | | | 1 1/16 |
| | 1 | SKZNM-06-16 | 2.14 | | | 1 3/8 |
| 1/2 | 1/8 | SKZNM-08-02 | 1.53 | 0.90 | 0.19 | 13/16 |
| | 1/4 | SKZNM-08-04 | 1.71 | | | 13/16 |
| | 3/8 | SKZNM-08-06 | 1.71 | | | 13/16 |
| | 1/2 | SKZNM-08-08 | 1.93 | | | 7/8 |
| | 3/4 | SKZNM-08-12 | 1.99 | | | 1 1/16 |
| | 1 | SKZNM-08-16 | 2.25 | | | 1 3/8 |
| 5/8 | 1/4 | SKZNM-10-04 | 1.74 | 0.96 | 0.28 | 15/16 |
| | 3/8 | SKZNM-10-06 | 1.74 | | | 15/16 |
| | 1/2 | SKZNM-10-08 | 1.93 | | | 15/16 |
| | 3/4 | SKZNM-10-12 | 1.99 | | | 1 1/16 |
| 3/4 | 3/8 | SKZNM-12-06 | 1.80 | 0.96 | 0.41 | 1 1/16 |
| | 1/2 | SKZNM-12-08 | 1.99 | | | 1 1/16 |
| | 3/4 | SKZNM-12-12 | 1.99 | | | 1 1/16 |
| | 1 | SKZNM-12-16 | 2.25 | | | 1 3/8 |
| 7/8 | 1/2 | SKZNM-14-08 | 1.99 | 1.02 | 0.47 | 1 3/16 |
| | 3/4 | SKZNM-14-12 | 1.99 | | | 1 3/16 |
| | 1 | SKZNM-14-16 | 2.25 | | | 1 3/8 |
| 1 | 1/2 | SKZNM-16-08 | 2.26 | 1.23 | 0.47 | 1 3/8 |
| | 3/4 | SKZNM-16-12 | 2.26 | | | 1 3/8 |
| | 1 | SKZNM-16-16 | 2.45 | | | 1 3/8 |
| 1 1/8 | 1 | SKZNM-18-16 | 2.45 | 1.23 | 0.88 | 1 5/8 |
| 1 1/4 | 1 | SKZNM-20-16 | 3.04 | 1.62 | 0.88 | 1 3/4 |
| | 1 1/4 | SKZNM-20-20 | | | | |
| 1 1/2 | 1 1/2 | SKZNM-24-24 | 3.50 | 1.97 | 1.34 | 2 1/8 |
| 2 | 2 | SKZNM-32-32 | 4.47 | 2.66 | 1.81 | 2 3/4 |

① 尺寸 E 是最小公称孔口。这些接头在管螺纹/直螺纹端可能会有更大的孔口。

| 卡套管 外径 | NPT 尺寸 in. | 基本 订购号 | 尺寸 | | | |
|-----------|------------------|--------------|------|------|----------------|----|
| | | | A | D | E ^① | F |
| 尺寸、mm | | | | | | |
| 2 | 1/8 | SKZNM-2M-02 | 30.5 | 12.9 | 1.7 | 12 |
| | 1/4 | SKZNM-3M-04 | 35.6 | | | 14 |
| 3 | 1/8 | SKZNM-3M-02 | 30.5 | 12.9 | 2.4 | 12 |
| | 1/4 | SKZNM-3M-04 | 35.6 | | | 14 |
| 4 | 1/8 | SKZNM-4M-02 | 31.2 | 13.7 | 2.4 | 12 |
| | 1/4 | SKZNM-4M-04 | 36.3 | | | 14 |
| 6 | 1/8 | SKZNM-6M-02 | 32.8 | 15.3 | 4.8 | 14 |
| | 1/4 | SKZNM-6M-04 | 37.9 | | | 14 |
| | 3/8 | SKZNM-6M-06 | 38.4 | | | 18 |
| | 1/2 | SKZNM-6M-08 | 44.7 | | | 22 |
| 8 | 1/8 | SKZNM-8M-02 | 34.2 | 16.2 | 4.8 | 15 |
| | 1/4 | SKZNM-8M-04 | 38.7 | | | 15 |
| | 3/8 | SKZNM-8M-06 | 39.3 | | | 18 |
| | 1/2 | SKZNM-8M-08 | 45.6 | | | 22 |
| 10 | 1/8 | SKZNM-10M-02 | 36.3 | 17.2 | 4.8 | 18 |
| | 1/4 | SKZNM-10M-04 | 40.9 | | | 18 |
| | 3/8 | SKZNM-10M-06 | 40.9 | | | 18 |
| | 1/2 | SKZNM-10M-08 | 46.5 | | | 22 |
| 12 | 3/4 | SKZNM-10M-12 | 48.0 | 22.8 | 7.9 | 27 |
| | 1/8 | SKZNM-12M-02 | 38.8 | | | 22 |
| | 1/4 | SKZNM-12M-04 | 43.4 | | | 22 |
| | 3/8 | SKZNM-12M-06 | 43.4 | | | 22 |
| 14 | 1/2 | SKZNM-12M-08 | 49.0 | 24.4 | 9.5 | 22 |
| | 3/4 | SKZNM-12M-12 | 50.5 | | | 22 |
| | 1/4 | SKZNM-14M-04 | 44.1 | | | 24 |
| | 3/8 | SKZNM-14M-06 | 44.1 | | | 24 |
| 15 | 1/2 | SKZNM-14M-08 | 49.0 | 24.4 | 11.1 | 24 |
| | 3/4 | SKZNM-14M-12 | 49.0 | | | 24 |
| 16 | 3/8 | SKZNM-16M-06 | 44.1 | 24.4 | 9.5 | 24 |
| | 1/2 | SKZNM-16M-08 | 49.0 | | | 24 |
| | 3/4 | SKZNM-16M-12 | 50.5 | | | 27 |
| 18 | 1/2 | SKZNM-18M-08 | 50.5 | 24.4 | 11.9 | 24 |
| | 3/4 | SKZNM-18M-12 | 50.5 | | | 27 |
| 20 | 1/2 | SKZNM-20M-08 | 52.3 | 26.0 | 11.9 | 30 |
| | 3/4 | SKZNM-20M-12 | 52.3 | | | 30 |
| 22 | 3/4 | SKZNM-22M-12 | 52.3 | 26.0 | 15.9 | 30 |
| | 1 | SKZNM-22M-16 | 57.1 | | | 35 |
| 25 | 1/2 | SKZNM-25M-08 | 57.5 | 31.3 | 11.9 | 35 |
| | 3/4 | SKZNM-25M-12 | 57.5 | | | 35 |
| | 1 | SKZNM-25M-16 | 62.3 | | | 35 |
| 28 | 1 | SKZNM-28M-16 | 72.4 | 36.6 | 21.8 | 41 |
| | 1 1/4 | SKZNM-28M-20 | 73.1 | | | 46 |
| 30 | 1 1/4 | SKZNM-30M-20 | 77.2 | 39.6 | 26.2 | 46 |
| 32 | 1 1/4 | SKZNM-32M-20 | 79.6 | 42.0 | 28.6 | 46 |
| 38 | 1 1/2 | SKZNM-38M-24 | 91.6 | 49.4 | 33.7 | 55 |

① 尺寸 E 是最小公称孔口。这些接头在管螺纹/直螺纹端可能会有更大的孔口。

备注：N代表美制NPT螺纹
M代表外螺纹

1.3 卡套直通接头

卡套外螺纹直通
SKZRT

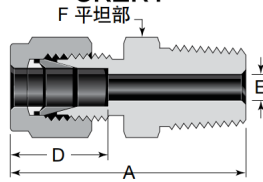

RT

| 卡套管 外径 | ISO 螺纹 尺寸 | 基本 订购号 | 尺寸 | | | |
|-----------|-----------------|----------------------------|--------------|------|----------------|--------------|
| | | | A | D | E ^① | F |
| 尺寸、in. | | | | | | |
| 1/8 | 1/8 1/4 | SKZRT-02-02 SKZRT-02-04 | 1.20 1.40 | 0.50 | 0.09 | 7/16 9/16 |
| 1/4 | 1/8 | SKZRT-04-02 | 1.29 | 0.60 | 0.19 | 1/2 |
| | 1/4 | SKZRT-04-04 | 1.49 | | | 9/16 |
| | 3/8 | SKZRT-04-06 | 1.51 | | | 11/16 |
| | 1/2 | SKZRT-04-08 | 1.76 | | | 7/8 |
| 5/16 | 1/8 | SKZRT-05-02 | 1.34 | 0.64 | 0.19 | 9/16 |
| | 1/4 | SKZRT-05-04 | 1.52 | | | |
| 3/8 | 1/8 | SKZRT-06-02 | 1.39 | 0.66 | 0.19 | 5/8 |
| | 1/4 | SKZRT-06-04 | 1.57 | | 0.28 | 5/8 |
| | 3/8 | SKZRT-06-06 | 1.57 | | 0.28 | 11/16 |
| | 1/2 | SKZRT-06-08 | 1.82 | | 0.28 | 7/8 |
| | 3/4 | SKZRT-06-12 | 1.88 | | 0.28 | 1 1/16 |
| 1/2 | 1/4 | SKZRT-08-04 | 1.71 | 0.90 | 0.28 | 13/16 |
| | 3/8 | SKZRT-08-06 | 1.71 | | 0.38 | 13/16 |
| | 1/2 | SKZRT-08-08 | 1.93 | | 0.41 | 7/8 |
| | 3/4 | SKZRT-08-12 | 1.99 | | 0.41 | 1 1/16 |
| 5/8 | 1/2 | SKZRT-10-08 | 1.93 | 0.96 | 0.47 | 15/16 |
| 3/4 | 3/4 | SKZRT-12-12 | 1.99 | 0.96 | 0.62 | 1 1/16 |
| | 1 | SKZRT-12-16 | 2.25 | | | 1 3/8 |
| 1 | 3/4 | SKZRT-16-12 | 2.26 | 1.23 | 0.63 | 1 3/8 |
| | 1 | SKZRT-16-16 | 2.45 | | | 0.88 |
| 1 1/4 | 1 1/4 | SKZRT-20-20 | 3.04 | 1.62 | 1.09 | 1 3/4 |

① 尺寸 E 是最小公称孔口。这些接头在管螺纹/直螺纹端可能会有更大的孔口。

备注：RT-英制锥管R外螺纹

| 卡套管 外径 | ISO 螺纹 尺寸 in. | 基本 订购号 | 尺寸 | | | |
|-----------|------------------------|--------------|------|------|----------------|----|
| | | | A | D | E ^① | F |
| 尺寸、mm | | | | | | |
| 2 | 1/8 | SKZRT-2M-02 | 30.5 | 12.9 | 1.7 | 12 |
| 3 | 1/8 | SKZRT-3M-02 | 30.5 | 12.9 | 2.4 | 12 |
| | 1/4 | SKZRT-3M-04 | 35.6 | | | 14 |
| 4 | 1/8 | SKZRT-4M-02 | 31.2 | 13.7 | 2.4 | 12 |
| | 1/4 | SKZRT-4M-04 | 36.3 | | | 14 |
| 6 | 1/8 | SKZRT-6M-02 | 32.8 | 15.3 | 4.8 | 14 |
| | 1/4 | SKZRT-6M-04 | 37.9 | | | 14 |
| | 3/8 | SKZRT-6M-06 | 38.4 | | | 18 |
| | 1/2 | SKZRT-6M-08 | 44.7 | | | 22 |
| 8 | 1/8 | SKZRT-8M-02 | 34.2 | 16.2 | 4.8 | 15 |
| | 1/4 | SKZRT-8M-04 | 38.7 | | 6.4 | 15 |
| | 3/8 | SKZRT-8M-06 | 39.2 | | 6.4 | 18 |
| | 1/2 | SKZRT-8M-08 | 45.6 | | 6.4 | 22 |
| 10 | 1/8 | SKZRT-10M-02 | 36.3 | 17.2 | 4.8 | 18 |
| | 1/4 | SKZRT-10M-04 | 40.9 | | 7.1 | 18 |
| | 3/8 | SKZRT-10M-06 | 40.9 | | 7.9 | 18 |
| | 1/2 | SKZRT-10M-08 | 46.5 | | 7.9 | 22 |
| | 3/4 | SKZRT-10M-12 | 48.0 | | 7.9 | 27 |
| 12 | 1/4 | SKZRT-12M-04 | 43.4 | 22.8 | 7.1 | 22 |
| | 3/8 | SKZRT-12M-06 | 43.4 | | 9.5 | 22 |
| | 1/2 | SKZRT-12M-08 | 49.0 | | 9.5 | 22 |
| | 3/4 | SKZRT-12M-12 | 50.5 | | 9.5 | 27 |
| 14 | 1/4 | SKZRT-14M-04 | 44.1 | 24.4 | 7.1 | 24 |
| | 3/8 | SKZRT-14M-06 | 44.1 | | 9.5 | |
| 15 | 1/2 | SKZRT-15M-08 | 49.0 | 24.4 | 11.9 | 24 |
| 16 | 1/4 | SKZRT-16M-04 | 44.1 | 24.4 | 7.1 | 24 |
| | 3/8 | SKZRT-16M-06 | 44.1 | | 9.5 | 24 |
| | 1/2 | SKZRT-16M-08 | 49.0 | | 11.9 | 24 |
| | 3/4 | SKZRT-16M-12 | 50.5 | | 12.7 | 27 |
| 18 | 1/2 | SKZRT-18M-08 | 50.5 | 24.4 | 11.9 | 27 |
| | 3/4 | SKZRT-18M-12 | 50.5 | | 15.1 | |
| 20 | 1/2 | SKZRT-20M-08 | 52.3 | 26.0 | 11.9 | 30 |
| | 3/4 | SKZRT-20M-12 | 52.3 | | 15.9 | |
| 22 | 3/4 | SKZRT-22M-12 | 52.3 | 26.0 | 15.9 | 30 |
| | 1 | SKZRT-22M-16 | 57.1 | | 18.3 | 35 |
| 25 | 1/2 | SKZRT-25M-08 | 57.5 | 31.3 | 11.9 | 35 |
| | 3/4 | SKZRT-25M-12 | 57.5 | | 15.9 | |
| | 1 | SKZRT-25M-16 | 62.3 | | 21.8 | |
| 28 | 1 | SKZRT-28M-16 | 72.4 | 36.6 | 21.8 | 41 |
| | 1 1/4 | SKZRT-28M-20 | 73.1 | | | 46 |
| 30 | 1 1/4 | SKZRT-30M-20 | 77.2 | 39.6 | 26.2 | 46 |
| 32 | 1 1/4 | SKZRT-32M-20 | 79.6 | 42.0 | 28.6 | 46 |
| 38 | 1 1/2 | SKZRT-38M-24 | 91.6 | 49.4 | 33.7 | 55 |

① 尺寸 E 是最小公称孔口。这些接头在管螺纹/直螺纹端可能会有更大的孔口。

1.3 卡套直通接头

卡套穿板外螺纹直通
SKZCBNM

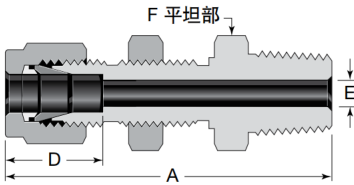

穿板 NPT

| 卡套管 外径 | NPT 尺寸 in. | 基本 订购号 | 尺寸 | | | | | |
|-----------|------------------|----------------|------|------|----------------|--------|-----------|------------|
| | | | A | D | E ^① | F | 面板孔 尺寸 | 最大 面板厚度 |
| 尺寸, in. | | | | | | | | |
| 1/8 | 1/8 | SKZCBNM-02-02 | 1.83 | 0.50 | 0.09 | 1/2 | 21/64 | 0.50 |
| 1/4 | 1/8 | SKZCBNM-04-02 | 1.95 | 0.60 | 0.19 | 5/8 | 29/64 | 0.40 |
| | 1/4 | SKZCBNM-04-04 | 2.13 | | | | | |
| 3/8 | 1/4 | SKZCBNM-06-04 | 2.26 | 0.66 | 0.28 | 3/4 | 37/64 | 0.44 |
| | 3/8 | SKZCBNM-06-06 | 2.26 | | | | | |
| | 1/2 | SKZCBNM-06-08 | 2.51 | | | | | |
| 1/2 | 3/8 | SKZCBNM-08-06 | 2.49 | 0.90 | 0.38 0.41 | 15/16 | 49/64 | 0.50 |
| | 1/2 | SKZCBNM-08-08 | 2.71 | | | | | |
| 3/4 | 3/4 | SKZCBNM-12-12 | 3.00 | 0.96 | 0.62 | 1 3/16 | 1 1/64 | 0.66 |
| 1 | 1 | SKZCBNM-16-16 | 3.67 | 1.23 | 0.88 | 1 5/8 | 1 21/64 | 0.75 |
| 尺寸, mm | | | | | | | | |
| 6 | 1/8 | SKZCBNM-6M-02 | 49.5 | 15.3 | 4.8 | 16 | 11.5 | 10.2 |
| | 1/4 | SKZCBNM-6M-04 | 53.6 | | | | | |
| 12 | 1/2 | SKZCBNM-12M-08 | 68.8 | 22.8 | 9.5 | 24 | 19.5 | 12.7 |

① 尺寸 E 是最小公称孔口。这些接头在管螺纹/直螺纹端可能会有更大的孔口。

卡套承插焊直通
SKZCW

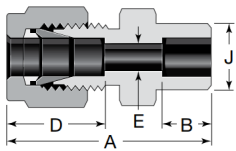

卡套管承插焊

| 卡套管 外径 | 承插焊 尺寸 | 基本 订购号 | 尺寸 | | | | |
|-----------|-----------|-------------|------|------|------|------|------|
| | | | A | B | D | E | J |
| 尺寸, in. | | | | | | | |
| 1/8 | 1/8 | SKZCW-02-02 | 1.14 | 0.10 | 0.50 | 0.09 | 0.29 |
| 1/4 | 1/4 | SKZCW-04-04 | 1.32 | 0.28 | 0.60 | 0.19 | 0.48 |
| 3/8 | 3/8 | SKZCW-06-06 | 1.48 | 0.31 | 0.66 | 0.28 | 0.60 |
| 1/2 | 1/2 | SKZCW-08-08 | 1.62 | 0.38 | 0.90 | 0.41 | 0.73 |
| 3/4 | 3/4 | SKZCW-12-12 | 1.71 | 0.44 | 0.96 | 0.62 | 1.04 |
| 1 | 1 | SKZCW-16-16 | 2.07 | 0.62 | 1.23 | 0.88 | 1.36 |

备注: CW-承插焊

卡套管外焊直通
SKZGW

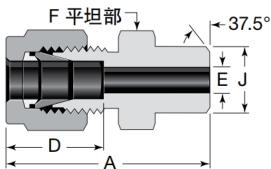

公称管外焊 (英制)

| 卡套管 外径 | 公称管 焊接 尺寸 | 基本 订购号 | 尺寸 | | | | |
|-----------|-----------------|-------------|------|------|----------------|--------|-------|
| | | | A | D | E ^① | F | J |
| 尺寸, in. | | | | | | | |
| 1/8 | 1/8 | SKZGW-02-02 | 1.20 | 0.50 | 0.09 | 7/16 | 0.405 |
| 3/16 | 1/8 | SKZGW-03-02 | 1.23 | 0.54 | 0.12 | 7/16 | 0.405 |
| 1/4 | 1/8 | SKZGW-04-02 | 1.29 | 0.60 | 0.19 | 1/2 | 0.405 |
| | 1/4 | SKZGW-04-04 | 1.49 | | | 9/16 | 0.540 |
| 5/16 | 1/8 | SKZGW-05-02 | 1.34 | 0.64 | 0.21 0.25 | 9/16 | 0.405 |
| | 1/4 | SKZGW-05-04 | 1.52 | | | | 0.540 |
| 3/8 | 1/4 | SKZGW-06-04 | 1.57 | 0.66 | 0.28 | 5/8 | 0.540 |
| | 3/8 | SKZGW-06-06 | 1.57 | | | 11/16 | 0.675 |
| | 1/2 | SKZGW-06-08 | 1.82 | | | 7/8 | 0.840 |
| | 3/4 | SKZGW-06-12 | 1.88 | | | 1 1/6 | 1.050 |
| 1/2 | 3/8 | SKZGW-08-06 | 1.71 | 0.90 | 0.41 | 13/16 | 0.675 |
| | 1/2 | SKZGW-08-08 | 1.93 | | | 7/8 | 0.840 |
| | 3/4 | SKZGW-08-12 | 1.99 | | | 1 1/16 | 1.050 |
| | 1 | SKZGW-08-16 | 2.25 | | | 1 3/8 | 1.315 |
| 5/8 | 1/2 | SKZGW-10-08 | 1.93 | 0.96 | 0.50 | 15/16 | 0.840 |
| 3/4 | 1/2 | SKZGW-12-08 | 1.99 | 0.96 | 0.55 0.62 | 1 1/16 | 0.840 |
| | 3/4 | SKZGW-12-12 | | | | | 1.050 |
| 1 | 1 | SKZGW-16-16 | 2.45 | 1.23 | 0.88 | 1 3/8 | 1.315 |
| 1 1/4 | 1 1/4 | SKZGW-20-20 | 3.04 | 1.62 | 1.09 | 1 3/4 | 1.660 |
| 1 1/2 | 1 1/2 | SKZGW-24-24 | 3.50 | 1.97 | 1.34 | 2 1/8 | 1.900 |
| 2 | 2 | SKZGW-32-32 | 4.47 | 2.66 | 1.81 | 2 3/4 | 2.375 |

① 尺寸 E 是最小公称孔口。这些接头在焊接端可能会有更大的孔口。焊接端的壁厚基于规格 80 的公称管。

备注: GW-管外焊

1.3 卡套直通接头

卡套管外焊直通
SKZGW

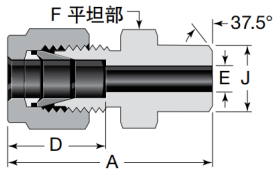

卡套内螺纹直通
SKZNF

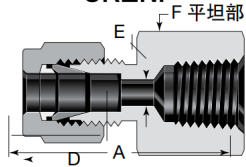

| 卡套管 外径 | 公称管 焊接 尺寸 in. | 基本 订购号 | 尺寸 | | | | | | | |
|-----------|------------------------|--------------|------|------|----------------|----|---------------------|------|------|--------|
| | | | A | D | E ^① | F | F, in. ^② | J | | |
| 尺寸, mm | | | | | | | | | | |
| 3 | 1/8 | SKZGW-3M-02 | 30.5 | 12.9 | 2.4 | 12 | 1/2 | 10.3 | | |
| 4 | 1/8 | SKZGW-4M-02 | 31.2 | 13.7 | 2.4 | 12 | 1/2 | 10.3 | | |
| 6 | 1/8 | SKZGW-6M-02 | 32.8 | 15.3 | 4.8 | 14 | 1/2 | 10.3 | | |
| | 1/4 | SKZGW-6M-04 | 37.9 | | | | | | 9/16 | 13.7 |
| 8 | 1/8 | SKZGW-8M-02 | 34.2 | 16.2 | 5.4 | 15 | 9/16 | 10.3 | | |
| | 1/4 | SKZGW-8M-04 | 38.7 | | 6.4 | | | | 13.7 | |
| | 1/2 | SKZGW-8M-08 | 45.6 | | 6.4 | | | | | 7/8 |
| 10 | 1/4 | SKZGW-10M-04 | 40.9 | 17.2 | 7.5 | 18 | 11/16 | 13.7 | | |
| | 3/8 | SKZGW-10M-06 | 40.9 | | 7.9 | | | | 17.1 | |
| | 1/2 | SKZGW-10M-08 | 46.5 | | 7.9 | | | | | 7/8 |
| 12 | 1/4 | SKZGW-12M-04 | 43.4 | 22.8 | 7.5 | 22 | 13/16 | 13.7 | | |
| | 3/8 | SKZGW-12M-06 | 43.4 | | 9.5 | | | | 17.1 | |
| | 1/2 | SKZGW-12M-08 | 49.0 | | 9.5 | | | | | 7/8 |
| | 3/4 | SKZGW-12M-12 | 50.5 | | 9.5 | | | | 27 | 1 1/16 |
| 14 | 3/8 | SKZGW-14M-06 | 44.1 | 24.4 | 10.7 | 24 | 15/16 | 17.1 | | |
| 15 | 1/2 | SKZGW-15M-08 | 49.0 | 24.4 | 11.9 | 24 | 15/16 | 21.3 | | |
| 16 | 1/2 | SKZGW-16M-08 | 49.0 | 24.4 | 12.7 | 24 | 15/16 | 21.3 | | |
| 18 | 1/2 | SKZGW-18M-08 | 50.5 | 24.4 | 13.9 | 27 | 1 1/16 | 21.3 | | |
| 30 | 1 1/4 | SKZGW-30M-20 | 77.2 | 39.6 | 26.2 | 46 | 46 mm | 42.2 | | |
| 32 | 1 1/4 | SKZGW-32M-20 | 79.6 | 42.0 | 28.6 | 46 | 46 mm | 42.2 | | |
| 38 | 1 1/2 | SKZGW-38M-24 | 91.6 | 49.4 | 33.7 | 55 | 55 mm | 48.3 | | |

① 尺寸 E 是最小公称孔口。这些接头在焊接端可能会有更大的孔口。焊接端的壁厚基于规格 80 的公称管。
② 该尺寸适用于钢质和铝质接头。

NPT

| 卡套管 外径 | NPT 尺寸 | 基本 订购号 | 尺寸 | | | |
|-----------|-----------|-------------|------|------|------|--------|
| | | | A | D | E | F |
| 尺寸, in. | | | | | | |
| 1/16 | 1/16 | SKZNF-01-01 | 0.93 | 0.34 | 0.05 | 7/16 |
| | 1/8 | SKZNF-01-02 | 0.96 | | | 9/16 |
| 1/8 | 1/8 | SKZNF-02-02 | 1.13 | 0.50 | 0.09 | 9/16 |
| | 1/4 | SKZNF-02-04 | 1.32 | | | 3/4 |
| 3/16 | 1/8 | SKZNF-03-02 | 1.17 | 0.54 | 0.12 | 9/16 |
| 1/4 | 1/8 | SKZNF-04-02 | 1.23 | 0.60 | 0.19 | 9/16 |
| | 1/4 | SKZNF-04-04 | 1.41 | | | 3/4 |
| | 3/8 | SKZNF-04-06 | 1.48 | | | 7/8 |
| | 1/2 | SKZNF-04-08 | 1.67 | | | 1 1/16 |
| 5/16 | 1/8 | SKZNF-05-02 | 1.26 | 0.64 | 0.25 | 9/16 |
| | 1/4 | SKZNF-05-04 | 1.45 | | | 3/4 |
| 3/8 | 1/8 | SKZNF-06-02 | 1.29 | 0.66 | 0.28 | 5/8 |
| | 1/4 | SKZNF-06-04 | 1.48 | | | 3/4 |
| | 3/8 | SKZNF-06-06 | 1.54 | | | 7/8 |
| | 1/2 | SKZNF-06-08 | 1.73 | | | 1 1/16 |
| | 3/4 | SKZNF-06-12 | 1.88 | | | 1 5/16 |
| 1/2 | 1/4 | SKZNF-08-04 | 1.59 | 0.90 | 0.41 | 13/16 |
| | 3/8 | SKZNF-08-06 | 1.65 | | | 7/8 |
| | 1/2 | SKZNF-08-08 | 1.84 | | | 1 1/16 |
| | 3/4 | SKZNF-08-12 | 1.90 | | | 1 5/16 |
| 5/8 | 3/8 | SKZNF-10-06 | 1.65 | 0.96 | 0.50 | 15/16 |
| | 1/2 | SKZNF-10-08 | 1.84 | | | 1 1/16 |
| | 3/4 | SKZNF-10-12 | 1.90 | | | 1 5/16 |
| 3/4 | 1/2 | SKZNF-12-08 | 1.84 | 0.96 | 0.62 | 1 1/16 |
| | 3/4 | SKZNF-12-12 | 1.90 | | | 1 5/16 |
| 7/8 | 3/4 | SKZNF-14-12 | 1.96 | 1.02 | 0.72 | 1 5/16 |
| 1 | 3/4 | SKZNF-16-12 | 2.10 | 1.23 | 0.88 | 1 3/8 |
| | 1 | SKZNF-16-16 | 2.45 | | | 1 5/8 |
| 1 1/4 | 1 1/4 | SKZNF-20-20 | 2.94 | 1.62 | 1.09 | 2 1/8 |
| 1 1/2 | 1 1/2 | SKZNF-24-24 | 3.28 | 1.97 | 1.34 | 2 3/8 |
| 2 | 2 | SKZNF-32-32 | 4.00 | 2.66 | 1.81 | 2 7/8 |

| 卡套管 外径 | NPT 尺寸 in. | 基本 订购号 | 尺寸 | | | |
|-----------|------------------|--------------|------|------|------|----|
| | | | A | D | E | F |
| 尺寸, mm | | | | | | |
| 3 | 1/8 | SKZNF-3M-02 | 28.7 | 12.9 | 2.4 | 14 |
| | 1/4 | SKZNF-3M-04 | 33.5 | | | 19 |
| 4 | 1/8 | SKZNF-4M-02 | 29.7 | 13.7 | 2.4 | 14 |
| 6 | 1/8 | SKZNF-6M-02 | 31.3 | 15.3 | 4.8 | 14 |
| | 1/4 | SKZNF-6M-04 | 35.8 | | | 19 |
| | 3/8 | SKZNF-6M-06 | 37.6 | | | 22 |
| | 1/2 | SKZNF-6M-08 | 42.5 | | | 27 |
| 8 | 1/8 | SKZNF-8M-02 | 32.1 | 16.2 | 6.4 | 15 |
| | 1/4 | SKZNF-8M-04 | 37.0 | | | 19 |
| | 3/8 | SKZNF-8M-06 | 38.5 | | | 22 |
| | 1/2 | SKZNF-8M-08 | 43.3 | | | 27 |
| 10 | 1/4 | SKZNF-10M-04 | 37.8 | 17.2 | 7.9 | 19 |
| | 3/8 | SKZNF-10M-06 | 39.4 | | | 22 |
| | 1/2 | SKZNF-10M-08 | 44.2 | | | 27 |
| | 3/4 | SKZNF-10M-12 | 46.7 | | | 27 |
| 12 | 1/4 | SKZNF-12M-04 | 40.3 | 22.8 | 9.5 | 22 |
| | 3/8 | SKZNF-12M-06 | 41.9 | | | 22 |
| | 1/2 | SKZNF-12M-08 | 46.7 | | | 27 |
| 15 | 1/2 | SKZNF-15M-08 | 46.7 | 24.4 | 11.9 | 27 |
| 16 | 1/2 | SKZNF-16M-08 | 46.9 | 24.4 | 12.7 | 27 |
| 20 | 1/2 | SKZNF-20M-08 | 47.9 | 26.0 | 15.9 | 30 |
| | 3/4 | SKZNF-20M-12 | 49.7 | | | 35 |
| 22 | 3/4 | SKZNF-22M-12 | 49.7 | 26.0 | 18.3 | 35 |
| | 1 | SKZNF-22M-16 | 57.9 | | | 41 |
| 25 | 3/4 | SKZNF-25M-12 | 53.4 | 31.3 | 21.8 | 35 |
| | 1 | SKZNF-25M-16 | 62.3 | | | 41 |

备注: N-美制NPT
F-内螺纹

1.3 卡套直通接头

卡套内螺纹直通
SKZRC

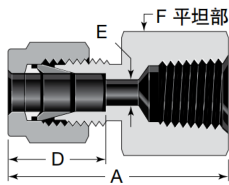

Rc

| 卡套管 外径 | ISO 螺纹 尺寸 in. | 基本 订购号 | 尺寸 | | | |
|-----------|------------------------|--------------|------|------|------|--------|
| | | | A | D | E | F |
| 尺寸、in. | | | | | | |
| 1/8 | 1/8 | SKZRC-02-02 | 1.13 | 0.50 | 0.09 | 9/16 |
| 1/4 | 1/8 | SKZRC-04-02 | 1.23 | 0.60 | 0.19 | 9/16 |
| | 1/4 | SKZRC-04-04 | 1.41 | | | 3/4 |
| | 3/8 | SKZRC-04-06 | 1.48 | | | 7/8 |
| | 1/2 | SKZRC-04-08 | 1.67 | | | 1 1/16 |
| 3/8 | 1/4 | SKZRC-06-04 | 1.48 | 0.66 | 0.28 | 3/4 |
| | 3/8 | SKZRC-06-06 | 1.54 | | | 7/8 |
| | 1/2 | SKZRC-06-08 | 1.73 | | | 1 1/16 |
| 1/2 | 1/4 | SKZRC-08-04 | 1.59 | 0.90 | 0.41 | 13/16 |
| | 3/8 | SKZRC-08-06 | 1.65 | | | 7/8 |
| | 1/2 | SKZRC-08-08 | 1.84 | | | 1 1/16 |
| 尺寸、mm | | | | | | |
| 3 | 1/8 | SKZRC-3M-02 | 28.7 | 12.9 | 2.4 | 14 |
| 6 | 1/8 | SKZRC-6M-02 | 31.3 | 15.3 | 4.8 | 14 |
| | 1/4 | SKZRC-6M-04 | 35.8 | | | 19 |
| | 3/8 | SKZRC-6M-06 | 37.6 | | | 22 |
| | 1/2 | SKZRC-6M-08 | 42.5 | | | 27 |
| 8 | 1/8 | SKZRC-8M-02 | 32.1 | 16.2 | 6.4 | 15 |
| | 1/4 | SKZRC-8M-04 | 37.0 | | | 19 |
| | 3/8 | SKZRC-8M-06 | 38.5 | | | 22 |
| | 1/2 | SKZRC-8M-08 | 43.3 | | | 27 |
| 10 | 1/8 | SKZRC-10M-02 | 33.0 | 17.2 | 7.9 | 18 |
| | 1/4 | SKZRC-10M-04 | 37.8 | | | 19 |
| | 3/8 | SKZRC-10M-06 | 39.4 | | | 22 |
| | 1/2 | SKZRC-10M-08 | 44.2 | | | 27 |
| 12 | 1/8 | SKZRC-12M-02 | 35.5 | 22.8 | 9.5 | 22 |
| | 1/4 | SKZRC-12M-04 | 40.3 | | | 22 |
| | 3/8 | SKZRC-12M-06 | 41.9 | | | 22 |
| | 1/2 | SKZRC-12M-08 | 46.7 | | | 27 |
| | 3/4 | SKZRC-12M-12 | 49.0 | | | 35 |
| 15 | 3/8 | SKZRC-15M-06 | 41.9 | 24.4 | 11.9 | 24 |
| | 1/2 | SKZRC-15M-08 | 46.7 | | | 27 |
| 20 | 1/2 | SKZRC-20M-08 | 47.9 | 26.0 | 15.9 | 30 |
| | 3/4 | SKZRC-20M-12 | 49.7 | | | 35 |
| 22 | 3/4 | SKZRC-22M-12 | 49.7 | 26.0 | 18.3 | 35 |
| | 1 | SKZRC-22M-16 | 57.9 | | | 41 |
| 25 | 3/4 | SKZRC-25M-12 | 53.4 | 31.3 | 21.8 | 35 |
| | 1 | SKZRC-25M-16 | 62.3 | | | 41 |

卡套穿板内螺纹直通
SKZCBNF

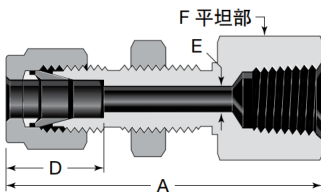

备注：Rc-英制螺纹密封锥管内螺纹

NPT

| 卡套管 外径 | NPT 尺寸 in. | 基本 订购号 | 尺寸 | | | | | 面板孔 尺寸 | 最大 面板厚度 |
|-----------|------------------|----------------|------|------|------|-------|-------|-----------|------------|
| | | | A | D | E | F | | | |
| 尺寸、in. | | | | | | | | | |
| 1/8 | 1/8 | SKZCBNF-02-02 | 1.76 | 0.50 | 0.09 | 9/16 | 21/64 | 0.50 | |
| 1/4 | 1/8 | SKZCBNF-04-02 | 1.85 | 0.60 | 0.19 | 5/8 | 29/64 | 0.40 | |
| | 1/4 | SKZCBNF-04-04 | 2.04 | | | | | | |
| 3/8 | 1/4 | SKZCBNF-06-04 | 2.17 | 0.66 | 0.28 | 3/4 | 37/64 | 0.44 | |
| 1/2 | 3/8 | SKZCBNF-08-06 | 2.43 | 0.90 | 0.41 | 15/16 | 49/64 | 0.50 | |
| | 1/2 | SKZCBNF-08-08 | 2.62 | | | | | | |
| 尺寸、mm | | | | | | | | | |
| 6 | 1/4 | SKZCBNF-6M-04 | 51.8 | 15.3 | 4.8 | 19 | 11.5 | 10.2 | |
| 12 | 1/2 | SKZCBNF-12M-08 | 66.5 | 22.8 | 9.5 | 27 | 19.5 | 12.7 | |

1.3 卡套直通接头

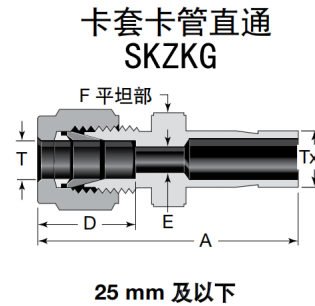
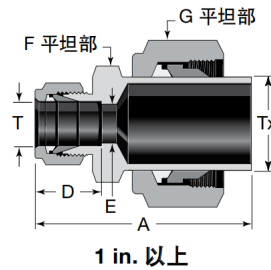
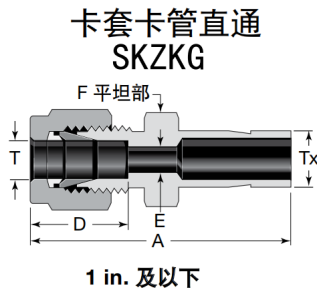

变径接头 (英制)

| 卡套管外径 | | 基本 订购号 | 尺寸 | | | | |
|---------|------------|----------------------------|--------------|------|--------|--------|-------|
| T | Tx | | A | D | E | F | G |
| 尺寸, in. | | | | | | | |
| 1/16 | 1/8 1/4 | SKZKG-01-02 SKZKG-01-04 | 1.15 1.24 | 0.34 | 0.05 | 5/16 | — |
| 1/8 | 1/16 | SKZKG-02-01 | 1.14 | 0.50 | 0.03 | 7/16 | — |
| | 1/8 | SKZKG-02-02 | 1.32 | | 0.08 | 7/16 | |
| | 3/16 | SKZKG-02-03 | 1.35 | | 0.09 | 7/16 | |
| | 1/4 | SKZKG-02-04 | 1.42 | | 0.09 | 7/16 | |
| | 3/8 | SKZKG-02-06 | 1.48 | | 0.09 | 7/16 | |
| | 1/2 | SKZKG-02-08 | 1.74 | 0.09 | 9/16 | | |
| 3/16 | 1/8 | SKZKG-03-02 | 1.37 | 0.54 | 0.08 | 7/16 | — |
| | 1/4 | SKZKG-03-04 | 1.46 | | 0.12 | 7/16 | |
| 1/4 | 1/8 | SKZKG-04-02 | 1.45 | 0.60 | 0.08 | 1/2 | — |
| | 3/16 | SKZKG-04-03 | 1.48 | | 0.12 | 1/2 | |
| | 1/4 | SKZKG-04-04 | 1.54 | | 0.17 | 1/2 | |
| | 5/16 | SKZKG-04-05 | 1.57 | | 0.19 | 1/2 | |
| | 3/8 | SKZKG-04-06 | 1.60 | | 0.19 | 1/2 | |
| | 1/2 | SKZKG-04-08 | 1.82 | | 0.19 | 9/16 | |
| | 5/8 | SKZKG-04-10 | 1.89 | | 0.19 | 11/16 | |
| | 3/4 | SKZKG-04-12 | 1.88 | 0.19 | 13/16 | | |
| 5/16 | 3/8 | SKZKG-05-06 | 1.65 | 0.64 | 0.25 | 9/16 | — |
| | 1/2 | SKZKG-05-08 | 1.87 | | | | |
| 3/8 | 1/4 | SKZKG-06-04 | 1.63 | 0.66 | 0.17 | 5/8 | — |
| | 3/8 | SKZKG-06-06 | 1.70 | | 0.27 | 5/8 | |
| | 1/2 | SKZKG-06-08 | 1.91 | | 0.28 | 5/8 | |
| | 5/8 | SKZKG-06-10 | 1.98 | | 0.28 | 11/16 | |
| | 3/4 | SKZKG-06-12 | 1.98 | | 0.28 | 13/16 | |
| 1/2 | 1/4 | SKZKG-08-04 | 1.77 | 0.90 | 0.17 | 13/16 | — |
| | 3/8 | SKZKG-08-06 | 1.84 | | 0.27 | 13/16 | |
| | 1/2 | SKZKG-08-08 | 2.06 | | 0.37 | 13/16 | |
| | 5/8 | SKZKG-08-10 | 2.12 | | 0.41 | 13/16 | |
| | 3/4 | SKZKG-08-12 | 2.12 | | 0.41 | 13/16 | |
| | 1 | SKZKG-08-16 | 2.37 | 0.41 | 1 1/16 | | |
| 5/8 | 3/4 | SKZKG-10-12 | 2.15 | 0.96 | 0.50 | 15/16 | — |
| | 7/8 | SKZKG-10-14 | 2.21 | | 15/16 | | |
| | 1 | SKZKG-10-16 | 2.40 | | 1 1/16 | | |
| 3/4 | 1/2 | SKZKG-12-08 | 2.15 | 0.96 | 0.37 | 1 1/16 | — |
| | 1 | SKZKG-12-16 | 2.46 | | 0.62 | 1 1/16 | |
| 1 | 1 1/4 | SKZKG-16-20① | 3.17 | 1.23 | 0.88 | 1 3/8 | 1 7/8 |
| | 1 1/2 | SKZKG-16-24① | 3.51 | | | 1 5/8 | 2 1/4 |
| | 2 | SKZKG-16-32① | 4.43 | | | 2 1/8 | 3 |
| 1 1/4 | 1 1/2 | SKZKG-20-24① | 4.10 | 1.62 | 1.09 | 1 3/4 | 2 1/4 |
| | 2 | SKZKG-20-32① | 4.93 | | | 2 1/8 | 3 |
| 1 1/2 | 2 | SKZKG-24-32① | 5.17 | 1.97 | 1.34 | 2 1/8 | 3 |

① 配备有螺母和预装卡套。

变径接头 (公制)

| 卡套管外径 | | 基本 订购号 | 尺寸 | | | | |
|--------|----|---------------|------|------|------|-----|------|
| T | Tx | | A | D | E | F | |
| 尺寸, mm | | | | | | | |
| 2 | 3 | SKZKG-2M-3M | 33.5 | 12.9 | 1.7 | 12 | |
| 3 | 4 | SKZKG-3M-4M | 35.0 | 12.9 | 2.4 | 12 | |
| | 6 | SKZKG-3M-6M | 36.1 | | | 14 | |
| | 10 | SKZKG-3M-10M | 38.4 | | | | |
| 4 | 6 | SKZKG-4M-6M | 37.1 | 13.7 | 2.4 | 12 | |
| 6 | 3 | SKZKG-6M-3M | 36.9 | 15.3 | 1.9 | 14 | |
| | 8 | SKZKG-6M-8M | 39.9 | | | 14 | |
| | 10 | SKZKG-6M-10M | 40.7 | | | 14 | |
| | 12 | SKZKG-6M-10M | 46.3 | | | 14 | |
| | 18 | SKZKG-6M-18M | 49.6 | 4.8 | 22 | | |
| 8 | 6 | SKZKG-8M-6M | 40.3 | 16.2 | 4.1 | 15 | |
| | 10 | SKZKG-8M-10M | 42.0 | | | 6.4 | |
| | 12 | SKZKG-8M-12M | 47.6 | | | 6.4 | |
| | | | | | | | |
| 10 | 6 | SKZKG-10M-6M | 42.4 | 17.2 | 4.1 | 18 | |
| | 8 | SKZKG-10M-8M | 43.4 | | | 18 | |
| | 12 | SKZKG-10M-12M | 49.8 | | | 18 | |
| | 15 | SKZKG-10M-15M | 51.3 | | | 18 | |
| | 18 | SKZKG-10M-15M | 51.3 | | | 18 | |
| | | | | | | 22 | |
| 12 | 6 | SKZKG-12M-6M | 44.9 | 22.8 | 4.1 | 22 | |
| | 8 | SKZKG-12M-8M | 45.9 | | | 22 | |
| | 10 | SKZKG-12M-10M | 46.7 | | | 7.1 | |
| | 16 | SKZKG-12M-16M | 53.8 | | | 9.5 | |
| | 18 | SKZKG-12M-18M | 53.8 | | | 9.5 | |
| | 20 | SKZKG-12M-20M | 56.1 | | | 9.5 | |
| | 22 | SKZKG-12M-22M | 56.1 | | | 9.5 | |
| | 25 | SKZKG-12M-25M | 62.4 | | | 9.5 | |
| 16 | 12 | SKZKG-16M-12M | 53.0 | 24.4 | 8.8 | 24 | |
| 18 | 12 | SKZKG-18M-12M | 54.6 | 24.4 | 8.8 | 27 | |
| | 16 | SKZKG-18M-16M | 56.1 | | | | 12.0 |
| | 20 | SKZKG-18M-20M | 57.6 | | | | 15.1 |
| | 22 | SKZKG-18M-22M | 57.6 | | | | 15.1 |
| | 25 | SKZKG-18M-25M | 62.4 | | | | 15.1 |
| 20 | 16 | SKZKG-20M-16M | 57.9 | 26.0 | 12.0 | 30 | |
| | 18 | SKZKG-20M-18M | 57.9 | | | | 13.9 |
| | 22 | SKZKG-20M-22M | 59.4 | | | | 15.9 |
| | 25 | SKZKG-20M-25M | 64.2 | | | | 15.9 |
| 22 | 18 | SKZKG-22M-18M | 57.9 | 26.0 | 13.9 | 30 | |
| | 20 | SKZKG-22M-20M | 59.4 | | | | 15.5 |
| | 25 | SKZKG-22M-25M | 64.2 | | | | 18.3 |
| | | | | | | | |
| 25 | 18 | SKZKG-25M-18M | 63.1 | 31.3 | 13.9 | 35 | |
| | 20 | SKZKG-25M-20M | 64.6 | | | | 15.5 |

备注: KG-卡套式直管

1.3 卡套直通接头

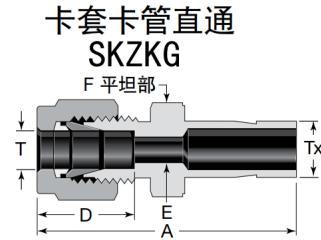
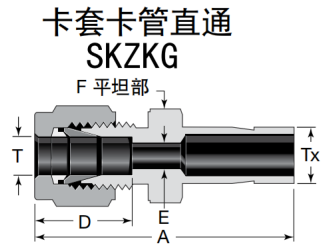

变径接头 (公制到英制)

| 卡套管外径 | | 基本 订购号 | 尺寸 | | | |
|--------|-------------|--------------|------|------|------|----|
| T | Tx, in. | | A | D | E | F |
| 尺寸, mm | | | | | | |
| 2 | 1/8 | SKZKG-2M-02 | 33.5 | 12.9 | 1.7 | 12 |
| 3 | 1/8 | SKZKG-3M-02 | 33.5 | 12.9 | 2.0 | 12 |
| | 1/4 | SKZKG-3M-04 | 36.1 | | 2.4 | |
| 4 | 1/4 | SKZKG-4M-04 | 37.1 | 13.7 | 2.4 | 12 |
| 6 | 1/8 | SKZKG-6M-02 | 36.9 | 15.3 | 2.0 | 14 |
| | 1/4 | SKZKG-6M-04 | 39.2 | | 4.4 | |
| | 5/16 | SKZKG-6M-05 | 39.9 | | 4.8 | |
| | 3/8 | SKZKG-6M-06 | 40.7 | | 4.8 | |
| 8 | 1/2 | SKZKG-6M-08 | 46.3 | | 4.8 | |
| | 1/4 | SKZKG-8M-04 | 40.3 | 16.2 | 4.4 | 15 |
| | 3/8 | SKZKG-8M-06 | 42.0 | | 6.4 | |
| 1/2 | SKZKG-8M-08 | 47.6 | 6.4 | | | |
| 10 | 3/8 | SKZKG-10M-06 | 44.2 | 17.2 | 6.8 | 18 |
| | 1/2 | SKZKG-10M-08 | 49.8 | | 7.9 | |
| 12 | 1/2 | SKZKG-12M-08 | 52.3 | 22.8 | 9.3 | 22 |
| | 3/4 | SKZKG-12M-12 | 53.8 | | 9.5 | |
| 18 | 3/4 | SKZKG-18M-12 | 56.1 | 24.4 | 14.7 | 27 |
| | 1 | SKZKG-18M-16 | 62.4 | | 15.1 | |
| 25 | 1 | SKZKG-25M-16 | 69.5 | 31.3 | 20.2 | 35 |

变径接头 (英制到公制)

| 卡套管外径 | | 基本 订购号 | 尺寸 | | | |
|---------|--------|-------------|------|------|------|------|
| T | Tx, mm | | A | D | E | F |
| 尺寸, in. | | | | | | |
| 1/8 | 6 | SKZKG-02-6M | 1.42 | 0.50 | 0.09 | 7/16 |

卡套长卡管直通
SKZCKG

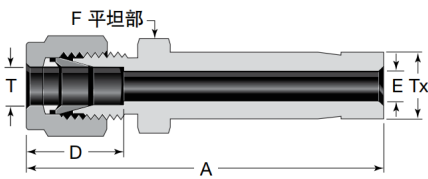

长变径接头

| 卡套管外径 | | 基本 订购号 | 尺寸 | | | |
|---------|-----|--------------|------|------|------|-----|
| T | Tx | | A | D | E | F |
| 尺寸, in. | | | | | | |
| 3/8 | 1/2 | SKZCKG-06-08 | 2.57 | 0.66 | 0.25 | 5/8 |

仅在世伟洛克内螺纹孔口上使用长变径接头。

备注: CKG-加长卡套式直管

卡套穿板卡管直通
SKZCBKG

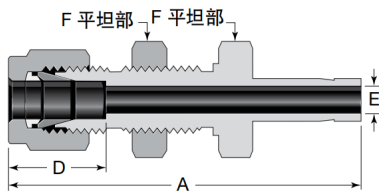

穿板变径接头

| 卡套管 外径 | 基本 订购号 | 尺寸 | | | | | 面板孔 尺寸 | 最大 面板厚度 |
|-----------|---------------|------|------|------|--------|---------|-----------|------------|
| | | A | D | E | F | | | |
| 尺寸, in. | | | | | | | | |
| 1/8 | SKZCBKG-02-02 | 1.95 | 0.50 | 0.08 | 1/2 | 21/64 | 0.50 | |
| 1/4 | SKZCBKG-04-04 | 2.20 | 0.60 | 0.17 | 5/8 | 29/64 | 0.40 | |
| 3/8 | SKZCBKG-06-06 | 2.41 | 0.66 | 0.27 | 3/4 | 37/64 | 0.44 | |
| 1/2 | SKZCBKG-08-08 | 2.87 | 0.90 | 0.37 | 15/16 | 49/64 | 0.50 | |
| 5/8 | SKZCBKG-10-10 | 2.96 | 0.96 | 0.47 | 1 1/16 | 57/64 | 0.50 | |
| 3/4 | SKZCBKG-12-12 | 3.21 | 0.96 | 0.58 | 1 3/16 | 1 1/64 | 0.66 | |
| 1 | SKZCBKG-16-16 | 3.95 | 1.23 | 0.80 | 1 5/8 | 1 21/64 | 0.75 | |