

**Features**

- 2-channel isolated barrier
- 24 V DC supply (Power Rail)
- Dry contact or NAMUR inputs
- Relay contact output
- Line fault detection (LFD)
- Reversible mode of operation
- Up to SIL2 acc. to IEC 61508

**Function**

This isolated barrier is used for intrinsic safety applications. It transfers digital signals (NAMUR sensors/mechanical contacts) from a hazardous area to a safe area.

The proximity sensor or switch controls a form C changeover relay contact for the safe area load. The normal output state can be reversed using switches S1 and S2. Switch S3 is used to enable or disable line fault detection of the field circuit.

During an error condition, the relays revert to their de-energized state and the LEDs indicate the fault according to NAMUR NE44.

A unique collective error messaging feature is available when used with the Power Rail system.

**Assembly**

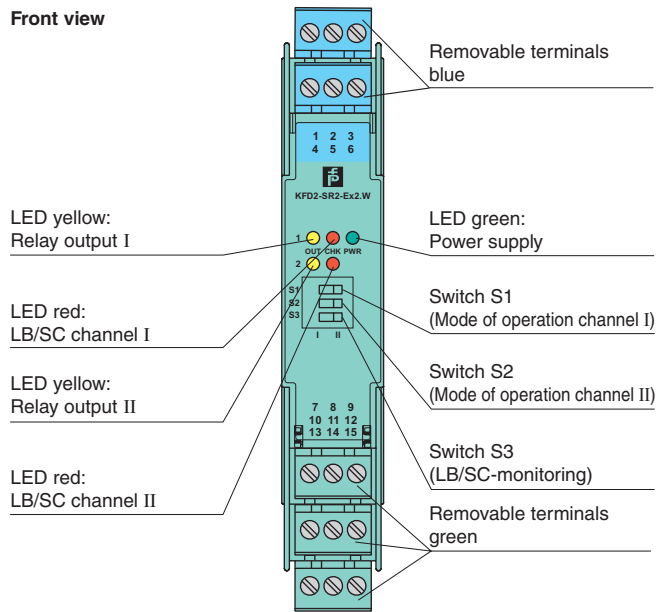

**Connection**

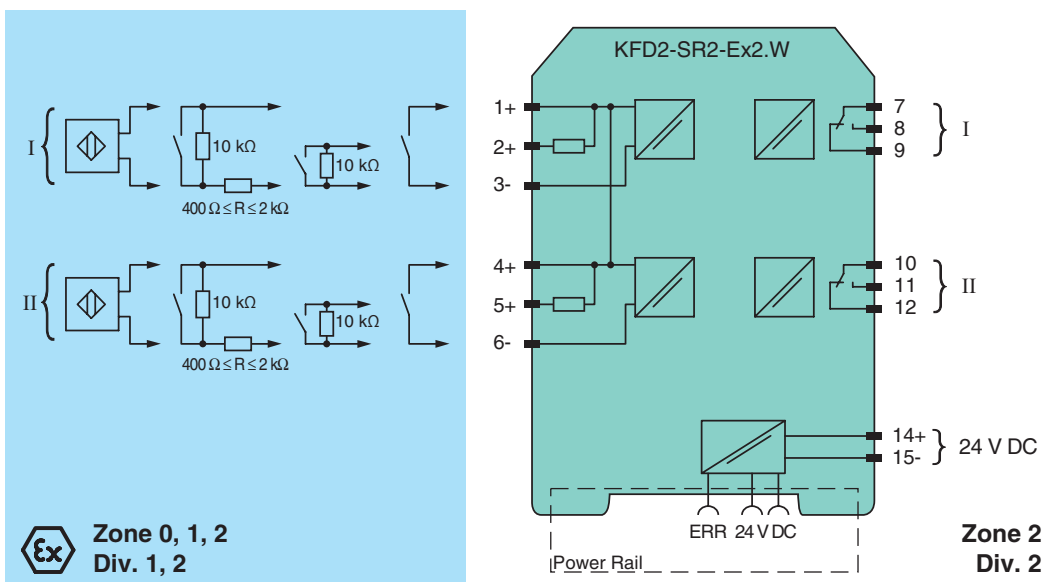

Release date 2012-07-06 08:53 Date of issue 2012-07-17 132960\_eng.xml

<b>General specifications</b>		
Signal type		Digital Input
<b>Supply</b>		
Connection		Power Rail or terminals 14+, 15-
Rated voltage		20 ... 30 V DC
Ripple		≤ 10 %
Rated current		≤ 50 mA
Power loss		1 W
Power consumption		< 1.3 W
<b>Input</b>		
Connection		terminals 1+, 2+, 3-; 4+, 5+, 6-
Rated values		acc. to EN 60947-5-6 (NAMUR)
Open circuit voltage/short-circuit current		approx. 8 V DC / approx. 8 mA
Switching point/switching hysteresis		1.2 ... 2.1 mA / approx. 0.2 mA
Line fault detection		breakage I ≤ 0.1 mA , short-circuit I > 6 mA
Pulse/Pause ratio		≥ 20 ms / ≥ 20 ms
<b>Output</b>		
Connection		output I: terminals 7, 8, 9 ; output II: terminals 10, 11, 12
Output I, II		signal, relay
Minimum switch current		2 mA / 24 V DC
Energized/De-energized delay		approx. 20 ms / approx. 20 ms
Mechanical life		10 <sup>7</sup> switching cycles
<b>Transfer characteristics</b>		
Switching frequency		≤ 10 Hz
<b>Electrical isolation</b>		
Input/Output		reinforced insulation according to IEC/EN 61010-1, rated insulation voltage 300 V <sub>eff</sub>
Input/power supply		reinforced insulation according to IEC/EN 61010-1, rated insulation voltage 300 V <sub>eff</sub>
Output/power supply		reinforced insulation according to IEC/EN 61010-1, rated insulation voltage 300 V <sub>eff</sub>
Output/Output		reinforced insulation according to IEC/EN 61010-1, rated insulation voltage 300 V <sub>eff</sub>
<b>Directive conformity</b>		
Electromagnetic compatibility		
Directive 2004/108/EC		EN 61326-1:2006
Low voltage		
Directive 2006/95/EC		EN 61010-1:2010
<b>Conformity</b>		
Electromagnetic compatibility		NE 21:2006
Protection degree		IEC 60529:2001
Input		EN 60947-5-6:2000
<b>Ambient conditions</b>		
Ambient temperature		-20 ... 60 °C (-4 ... 140 °F)
<b>Mechanical specifications</b>		
Protection degree		IP20
Mass		approx. 150 g
Dimensions		20 x 119 x 115 mm (0.8 x 4.7 x 4.5 in) , housing type B2
Mounting		on 35 mm DIN mounting rail acc. to EN 60715:2001
<b>Data for application in connection with Ex-areas</b>		
EC-Type Examination Certificate		PTB 00 ATEX 2080 , for additional certificates see <a href="http://www.pepperl-fuchs.com">www.pepperl-fuchs.com</a>
Group, category, type of protection		⊕ II (1) G [Ex ia] IIC, II (1) D [Ex ia] IIIC
Input		[Ex ia] IIC, [Ex ia] IIIC
Voltage	U <sub>o</sub>	10.5 V
Current	I <sub>o</sub>	13 mA
Power	P <sub>o</sub>	34 mW (linear characteristic)
Supply		
Maximum safe voltage	U <sub>m</sub>	253 V AC / 125 V DC (Attention! U <sub>m</sub> is no rated voltage.)
Output		
Contact loading		253 V AC/2 A/cos φ > 0.7; 126.5 V AC/4 A/cos φ > 0.7; 40 V DC/2 A resistive load
Maximum safe voltage	U <sub>m</sub>	253 V AC (Attention! The rated voltage can be lower.)
Statement of conformity		Pepperl+Fuchs
Group, category, type of protection		⊕ II (3)G [Ex ic] IIC; [Ex nL] IIC
Input		[Ex ic] IIC; [Ex nL] IIC
Voltage	U <sub>o</sub>	10.5 V
Current	I <sub>o</sub>	13 mA
Power	P <sub>o</sub>	34 mW (linear characteristic)

Release date 2012-07-06 08:53 Date of issue 2012-07-17 13:29:60\_eng.xml

<b>Output</b>	
Contact loading	253 V AC/2 A/cos $\phi > 0.7$ ; 126.5 V AC/4 A/cos $\phi > 0.7$ ; 40 V DC/2 A resistive load
Statement of conformity	TÜV 99 ATEX 1493 X , observe statement of conformity
Group, category, type of protection, temperature class	 II 3G Ex nA nC IIC T4
<b>Output</b>	
Contact loading	50 V AC/4 A/cos $\phi > 0.7$ ; 40 V DC/2 A resistive load
<b>Electrical isolation</b>	
Input/Output	safe electrical isolation acc. to IEC/EN 60079-11, voltage peak value 375 V
Input/power supply	safe electrical isolation acc. to IEC/EN 60079-11, voltage peak value 375 V
<b>Directive conformity</b>	
Directive 94/9/EC	EN 60079-0:2009, EN 60079-11:2007 , EN 60079-15:2005 , EN 61241-11:2006
<b>International approvals</b>	
<b>FM approval</b>	
Control drawing	116-0035
<b>CSA approval</b>	
Control drawing	116-0047
<b>IECEX approval</b>	
Approved for	[Ex ia] IIC , [Ex ia] IIIC , [Ex ia] I
<b>General information</b>	
Supplementary information	EC-Type Examination Certificate, Statement of Conformity, Declaration of Conformity, Attestation of Conformity and instructions have to be observed where applicable. For information see <a href="http://www.pepperl-fuchs.com">www.pepperl-fuchs.com</a> .

**Configuration**

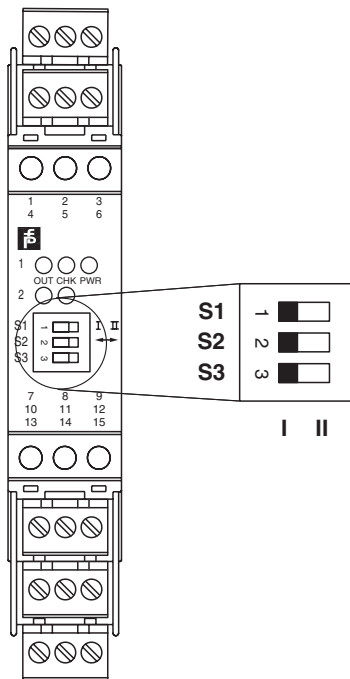

**Switch position**

S	Function		Position
1	Mode of operation Output I (relay) energized	with high input current	I
		with low input current	II
2	Mode of operation Output II (relay) energized	with high input current	I
		with low input current	II
3	Line fault detection	ON	I
		OFF	II

**Operating status**

Control circuit	Input signal
Initiator high impedance/ contact opened	low input current
Initiator low impedance/ contact closed	high input current
Lead breakage, lead short-circuit	Line fault

Factory settings: switch 1, 2 and 3 in position I

**Accessories**

**Power feed module KFD2-EB2**

The power feed module is used to supply the devices with 24 V DC via the Power Rail. The fuse-protected power feed module can supply up to 150 individual devices depending on the power consumption of the devices. A galvanically isolated mechanical contact uses the Power Rail to transmit collective error messages.

**Power Rail UPR-03**

The Power Rail UPR-03 is a complete unit consisting of the electrical inset and an aluminium profile rail 35 mm x 15 mm. To make electrical contact, the devices are simply engaged.

**Profile Rail K-DUCT with Power Rail**

The profile rail K-DUCT is an aluminum profile rail with Power Rail insert and two integral cable ducts for system and field cables. Due to this assembly no additional cable guides are necessary.



*Power Rail and Profile Rail must not be fed via the device terminals of the individual devices!*