



斯托姆科技

Full Metal AXIL

TÜV
CERT
ISO 9001:2000
ISO 14001:2004
ISO/TS16949:2002



STORM AC Full Metal AXIL FAN 172X150X55 Series



Dimensions (mm)

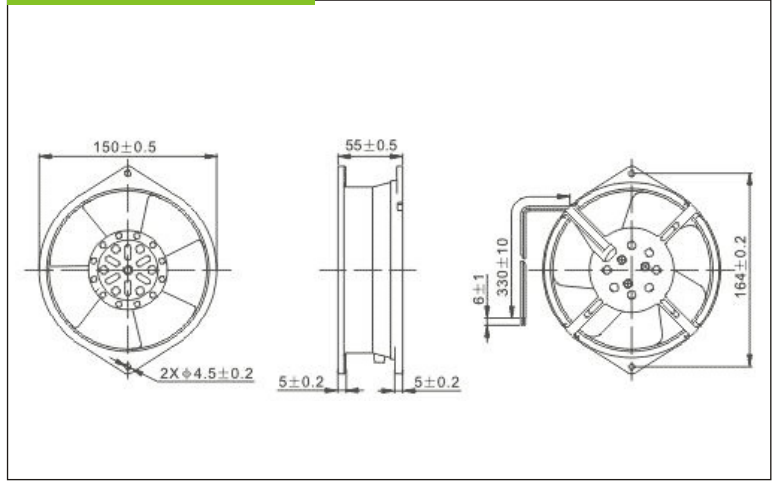

CONSTRUCTION:

- Die-cast cast aluminum housing
- Metal impeller or
- Glass fiber reinforced plastic:
- Impeller are UL 94V-0 rating
- Shaded pole motor/Impedance protected
- Leader wire or terminal is available

OPERATING TEMPERATURE:

- Ball bearing -30°C to +75°C
- Sleeve bearing -10°C to +70°C

Performance Curve

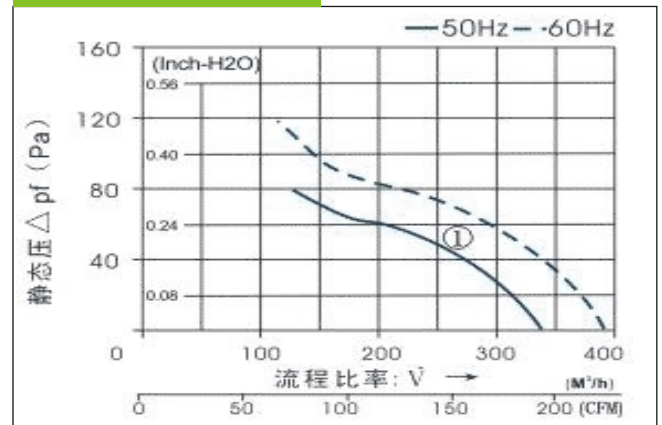

Model	Spec	RATED (VDC)	FREQ. (Hz)	CURRT (Amp)	POWER (Watts)	SPEED (Rpm)	AIR FLOW (CFM)	PRESSURE (In H ₂ O)	NOISE (dB-A)	Weight (g)	Curve
SA17255HB-11F		100/120	50/60	0.56/0.49	45/40	2700/3000	191/224	3.14/4.72	48/52	1100	①
SA17255HB-22F		200/240	50/60	0.33/0.28	47/41	2700/3000	191/224	3.14/4.72	48/52	1100	①