

ELECTRICAL TEMPERATURE SENSOR ASSEMBLY

The Exline Electrical Temperature Sensor Assembly is designed to open or close an electrical circuit when the device senses a predetermined temperature. Common applications include compressor discharge gas headers, lube oil, or jacket water headers on stationary engines, and heater treaters or similar fired vessels.

The assembly contains a temperature-sensitive eutectic alloy collar which holds a spring-loaded plunger in position under a micro switch. The collar melts at a predetermined temperature, releasing the plunger and opening or closing the switch.

The micro switch housing is dust tight and explosion proof malleable iron. The Thermowell and sensor assembly provide positive service in highly corrosive environments and the Thermowell is rated to withstand pressures of up to 8,000 psi.

The assembly represents an economical alternative to other types of sensing devices where absolute dependability is required, as in remote or unmanned installations.

The fuse-metal collar is the only required replacement when the sensor has been activated. Factory collar replacement is fast and inexpensive.



Nipple/ Union Electrical Temperature Sensor Assembly				
Thermowell Length (L)	Header Collar Threads	Thermowell Part No.	Striker Part No.	Nipple/ Union Assy. Part No.
1 13/16"	1/2" n.p.t.	300703	300310	310703
3 3/16"	1/2" n.p.t.	300718	300313	310718
4 3/16"	1/2" n.p.t.	300711	300315	310711
1 13/16"	3/4" n.p.t.	300722	300310	310722
3 3/16"	3/4" n.p.t.	300725	300313	310725
4 3/16"	3/4" n.p.t.	300712	300315	310712

Standard Electrical Temperature Sensor Assembly				
Thermowell Length (L)	Header Collar Threads	Thermowell Part No.	Striker Part No.	Standard Assy. Part No.
1 13/16"	1/2" NPT	300703	300306	310903
3 3/16"	1/2" NPT	300718	300309	310918
4 3/16"	1/2" NPT	300711	300311	310911
1 13/16"	3/4" NPT	300722	300306	310922
3 3/16"	3/4" NPT	300725	300309	310925
4 3/16"	3/4" NPT	300712	300311	310912

How to Order
Determine desired length of Thermowell, taking into account the depth of your mounting collar and the Thermowell threads. Next select the appropriate assembly part number. Then select desired collar melting temperature.

Available Eutectic Alloy Collar				
Melting Temps				
117°F	178°F	243°F	349°F	449°F
136°F	198°F	255°F	361°F	478°F
142°F	205°F	281°F	374°F	
150°F	217°F	291°F	390°F	
162°F	228°F	310°F	408°F	

Typical Areas Protected by the Electrical Temperature Sensor Assembly
• Discharge Gas Headers
• Jacket Water Headers
• Lube Oil Headers
• Heater Treaters and Fired Vessels

Electrical Component Specifications

Micro Switch Part No. 003078

· *Single Pole - Double Throw #V7-6C17D8-048-1

15.1 amps. & 1/2 hp 125, 250, or 277 V.A.C. 1/2 amp. 125 VDC; 1/4 amp. 250 VDC 5 amp. 120 VAC "L" (Lamp Load)

Malleable Iron Junction Unilet Part No. 350296

Explosion-Proof and Dust-Tight outlet box for hazardous locations. Class I, Groups C and D; Class II, Groups E, F, and G; and Class III.

Option: Copper Free 350296-A

*When ordering only the electrical shutdown box and micro switch, use part no. 350296 or 350296-A.

Details of Installation

Use 1/2" coupling (unless optional 3/4" n.p.t. Thermowell was ordered). Weld coupling to header or piping. Drill hole in header after coupling has been installed, taking care when drilling to prevent thread damage to the coupling.

Insert Thermowell through collar and tighten to add desired torque value. Use appropriate sealant on Thermowell threads.

Connect micro switch to control circuit using either NC or NO contacts and attach conduit to housing.

Standard Electrical Temperature Sensor Assembly

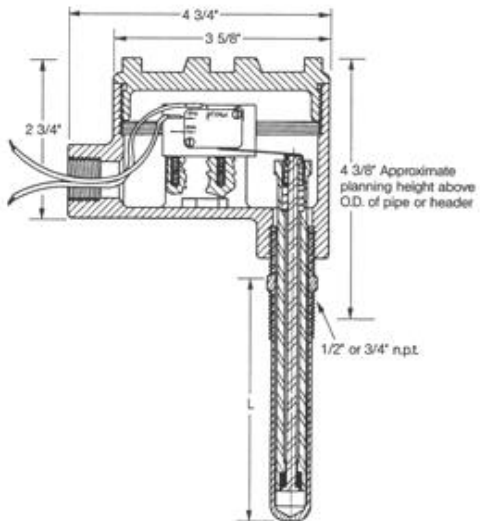

**Standard Electrical Temperature Sensor Assembly
With Nipple/Union Assembly**

